



Vacuum Pump Systems

RUTA

Forevacuum Pump Systems

DRYVAC

Dry Compressing Vacuum Pump Systems

Contents

Vacuum Pump Systems

Vacuum Pump Systems – oil sealed (RUTA) 6

General

Overview 6

Types of Pumps Systems 7

Products

Pump Systems

Oil Sealed Vacuum Pump Systems RUTA

Three-Stage Pump Systems

with Two-Stage TRIVAC Backing Pumps

Adaptor Version 10

Frame Version 12

Two-Stage Pump Systems

with Single-Stage SOGEVAC Backing Pumps

Adaptor Version 14

Frame Version 18

RBS - B/BCS Roots Pump Systems (Only available for purchase in North and South America)

with Two-Stage TRIVAC Backing Pumps. 22

HTS Close-Coupled Pump Systems (Only available for purchase in North and South America)

with Single-Stage SOGEVAC Backing Pumps. 26

Central Vacuum Supply Systems with SOGEVAC Pumps 30

Tank Mounted Medical Vacuum Systems (Only available for purchase in North and South America) 42

Vacuum Pump Systems – dry compressing (RUTA) 44

Products

Pump Systems

Dry Compressing Vacuum Pump System RUTA

with SCREWLINE Backing Pump

Adaptor Version

without palette 44

with palette 46

with SCREWLINE Backing Pump

Frame Version 50

Adaptor Version 56

SP Close-Coupled Pump Systems (Only available for purchase in North and South America)

with SCREWLINE Dry Compressing Backing Pumps 58

Dry Compressing Vacuum Pump System RUTA

Adaptor Version

with DRYVAC DV 650 Backing Pump 62

Frame Version

with DRYVAC DV 650 Backing Pump 64

with DRYVAC DV 1200 Backing Pump 66

DRYVAC Pump Systems	
Adaptor Version	
Load Lock Pump Systems	68
Process Pump Systems	70
with RUVAC WH Backing Pump	72
enclosed	74
Vacuum Pump Systems – dry compressing (DRYVAC)	76
Products	
Dry Compressing Pump Systems DRYVAC	
Basic System Configuration	81
Smart System Configuration	92
PowerBoost	104
RUVAC RAV Roots Vacuum Pumps with Pre-Admission Cooling	108
TVD Pump Systems for Drying, Evaporation and Distillation Applications	110
Accessories for oil sealed and dry compressing Pump Systems	
Sound Proofing	112
Isolation against Vibrations	112
Dust Separators	112
Frequency Converter RUVATRONIC RT 5.	112
Electric Controller	113
Pressure Control	113
Dust Filter F-xxx-C	114
Bellows with Vibration Absorbers	116
Bus Interfaces for Monitoring	117
Miscellaneous to oil sealed and dry compressing Pump Systems	
Checklist for Inquiries (Fax Form)	118
High Vacuum Pump Systems TURBOLAB	119
General	
General 87	
Applications and Accessories	119
Dry Pump Systems	120
Products	
Turbomolecular Pump Systems	
TURBOLAB 90i, 250i, 350i, 450i	119
Accessories for High Vacuum Pump Systems TMP	
Adsorption Traps with Aluminium Oxide Insert	132

UNIVEX High Vacuum Experimentation Systems	133
General	
General	133
Contents	134
Systems	
Box Coating Systems	135
Glove Box Systems	144
Cluster-Tool Systems	150
Dactyloscopy Systems	152
Space Simulation Systems	153
Process Accessories	154
General Accessories	166
UNIVEX Questionnaire	168
Calibration Systems	170
General	
CS Calibration Systems	170
Products	
CS Calibration Systems	171

General to Vacuum Pump Systems

Overview

A continually increasing number of applications in industry and research are relying on vacuum technology. Thus widely differing requirements result regarding the vacuum generating systems.

The comprehensive range of vacuum pumps from Leybold offers, in combination with the matching accessories, all options of selecting the optimum pump system for your application in each case.

Based on the longstanding experience in the design and manufacture of vacuum pump systems, Leybold offers standardized pump systems which will match most applications – the RUTA pump systems.

RUTA pump systems excel by being compact, reliable and service-friendly.

The pump systems are equipped as standard with 400 V, 50 Hz three-phase motors.

Motors for special supply voltages, special mains frequencies or explosion protected pumps are available.

Standards

Leybold pump systems are rated according to CE, ISO, DIN and VDE regulations. Compliance with other standards is possible upon request.

The technical data of the vacuum pump systems given in this catalog part are based on the PNEUROP Acceptance Specifications for Vacuum Pumps, Part 1, and comply with DIN 28 426. The characteristic curves in our pumping speed diagrams are plotted in accordance with DIN 28 426. The curves represent the mean of several measurements. Our warranty refers to the values indicated in the technical data table.

Designation of Roots Vacuum Pump Systems

Leybold pump combinations of Roots vacuum pumps with backing pumps are called "RUTA".

In order to identify the standard pump systems the name "RUTA" is followed by the brief designations of the pumps which make up a particular pump system.

Brief designation of the largest Roots vacuum pump (Pumping speed of the pump system)

Brief designation of the smaller Roots vacuum pump

Cooler or condenser (if present)

Brief designation of the backing pump

Type of pump system (adaptor (A) or frame (G))

The pump system designation is arranged as follows:

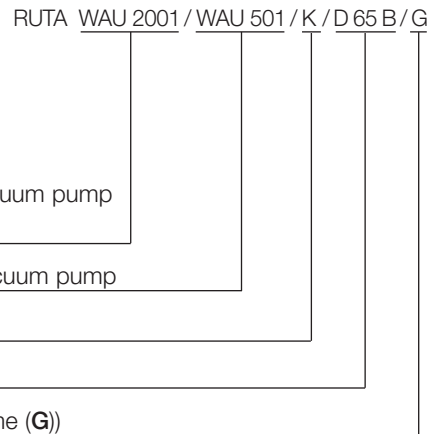

Part Numbers

The part numbers listed refer in each case to the standard version of the respective systems. Minor deviations are indicated by way of variants.

The variant V001 designates in each case the described version of the system.

The pump system RUTA WAU 2001/ SP630 F/G has Part No. 502 511 V001. When using the air-cooled screw pump SCREWLINE SP 630 then the variant will have the Part No. 502 511 V002. Minor deviations are special operating voltage, fitted accessories and custom painting for frame or pumps, for example.

The use of a different type of Roots vacuum pump, use of the WS 2001 instead of the WAU 2001, for example, is also treated as a variant. All variants with the same basic number have the same frame dimensions, the same distance between intake flange of the Roots pump and the exhaust flange of the backing pump.

Types of Pump Systems

Typical areas of application for RUTA pump systems are industry, research and chemistry. Here the focus is on processes for metal production and processing, drying and degassing, thermal treatment, coating in the area of solar components and semiconductor manufacture as well as surface refinement. RUTA pump systems are also used as backing pump sets for high vacuum systems in combination with diffusion pumps, turbomolecular pumps and cryo pumps.



RUTA WH7000/4xSV750BF/G

The RUTA pump systems described here have been designed for rough and medium vacuum operation, i.e. for the pressure range from atmospheric pressure down to 10^{-4} mbar (0.75×10^{-4} Torr). RUTA pump systems consist of a combination of individual pumps whereby Roots vacuum pumps are employed on the intake side. Further compression to atmospheric pressure may be performed either by oil sealed or dry compressing vacuum pumps, liquid ring pumps or Roots vacuum pumps with pre-inlet cooling. All combinations may be equipped at suitable places with condensers.

The selection criteria for a RUTA pump system are as follows:

- Pumping speed
- Operating pressure
- Process conditions
- Characteristics of the media
- Standards and regulations which depend on the area of application and the produced products.

Standard RUTA Pump Systems

Our Roots vacuum pumps WA, WH, WS and RA or WAU and WSU with integrated bypass line are combined with oil sealed backing pumps for conventional generation of the vacuum. Single-stage arrangements are capable of delivering pumping speeds of 250 to 16000 m³/h (147.3 to 9424 cfm). Higher pumping speeds can be attained by paralleling several pumps. The attainable operating pressures depend on the number of pumping stages.

For higher pumping speeds or lower ultimate pressures, also three-stage or multi-stage pump systems are available.

RUTA Pump Systems with Condensers

If vacuum systems must pump larger quantities of vapor or vapor gas mixtures, it is economical to insert condensers which are cooled with water or a different coolant at a suitable place within the pump system. Cooled condensers are themselves effective partial pumps which condense most of the vapors from the pumped media. The downstream mechanical pumps will then only need to pump those gases which have not already condensed.

The quantity of vapor present in each case determines the size of the condenser and the temperature at which it is operated. The size of the downstream pump is determined by the quantity of non-condensable gases, the required pressure and the required pump-down time for the system.

All pump systems of the WA/WAU, WS/WSU, WH and RA series may be equipped with one or several condensers. These are often used in the chemical industry. Here RUTA vacuum pump systems with condensers are not only used to generate a vacuum, but they are also often employed in the recovery of solvents. When installing one or several Roots pumps upstream of a condenser, low operating pressures and high condensation pressures can be attained. Thus the condenser may in many cases be operated with cooling water instead of brine. The vapor components pumped together with inert gases may be separated once more in an emission condenser on the exhaust side so that the quality of the exhaust gas can be maintained within close tolerance regarding its cleanness.

Dry Compressing RUTA Vacuum Pump Systems

Increasing environmental awareness, pumping of condensable vapors or high requirements regarding cleanliness when pumping high quality media which must not be contaminated by other media for recycling, often requires the use of universal pumps where the pump chamber is free of operating agents (dry pumps).

Here Leybold offers two solutions:

1. Pump systems with dry compressing vacuum pumps combined with one or several Roots vacuum pumps.
2. Single-stage RUTA RAV vacuum pump systems, consisting of Roots vacuum pumps with pre-admission cooling.

The operating pressure ranges of the pump systems depend on the number of Roots vacuum pumps, but will extend in any case without interruptions to atmospheric pressure.

Already in connection with one Roots pump, pump systems with a screw pump are capable of attaining base pressures of $< 1 \times 10^{-3}$ mbar (7.5×10^{-4} Torr).

Single-stage RAV combinations attain an ultimate pressure of 150 mbar (112.5 Torr).

Multi-stage combinations with Roots vacuum pumps of all systems are capable of attaining pressures below 10^{-4} mbar (7.5×10^{-5} Torr).

RUTA Custom Pump Systems

Most users will be able to select the right pump system for their application from our range of standard pump systems. In special cases a custom design may be required for special processes and high pumping speeds.

We are prepared to design and manufacture custom pump systems according to customers specifications. If required we will use – besides oil-sealed and dry compressing backing pumps – liquid ring and ejector pumps.

RUTA Pump Systems for the Metal Producing and Processing Industry

In common vacuum furnace processes such as hardening, annealing, brazing, melting and casting, preferably oil sealed or dry compressing standard vacuum pump systems are usually used.

The oil sealed systems consist of a combination of Roots vacuum pumps with a single or two-stage rotary vane or rotary piston pump.

In the dry compressing systems our screw vacuum pump SCREWLINE is used as the backing pump.

The vacuum pumps are mounted in a rugged frame. The design of the pump systems is service-friendly, modular and can be easily upgraded with additional equipment.

On smaller furnaces RUVAC WAU Roots vacuum pumps are the most suitable because these may be cut-in at a higher operating pressure, while on larger furnaces and particularly where short pump-down cycles are required, the use of RUVAC WH Roots vacuum pumps with suitably sized backing pumps is advisable. For special processes, e.g. fusion or degassing of molten masses, due to the high dust contents, the additional use of a dust separator is required as well as equipping the backing pumps with oil filtering units.

These additional units ensure utmost operational reliability of the pump systems even under the toughest operating conditions.



Pump system for the field of steel degassing

RUTA Pump Systems for the Photovoltaic and Coating Industry

In photovoltaic coating processes reactive, toxic and corrosive substances are generally used.

Frequently large quantities of dust for the pump system need to be expected. For such applications, Leybold has developed process pump combinations consisting of pumps from the DRYVAC line and Roots pumps from the RUVAC WS/WH line with optionally integrated controller.

The integrated electronics and sensor systems permit easy integration of the pump systems within the plant control system.

(For information on possible applications, see Catalog Part "Dry Compressing Screw Vacuum Pumps DRYVAC").

RUTA Pump Systems for the Chemical Industry

In chemical processes it is often necessary to remove corrosive, condensable and reactive gases and vapors. Leybold designs and manufactures custom-built pump systems for specific process applications. Depending on the type of application, either a rotary vane pump, or a dry compressing screw vacuum pump (SCREWLINE, for example), a liquid ring pump or a combination of gas jet pump and liquid ring pump may be used as the backing pump.

To ensure dependable monitoring of the system, the following monitoring devices, among others, may be installed:

- Temperature sensors to monitor the gas temperatures between the pump stages and the pump body temperature,
- Water flow monitors for the cooling water supply to pumps and condensers,
- Differential pressure indicator with control setpoint to monitor the exhaust filters of the rotary vane vacuum pump.

Pump Systems for Drying, Evaporation and Distillation Applications (TVD)

More and more vacuum applications are finding their way into the areas of environmental protection, recycling and waste disposal. "Waste disposal of used oil and aromatic compounds" and "Cleaning processes in metal-processing factories" demonstrate that the combination of vacuum know-how, innovative engineering and applications know-how is in-dispensable for the successful application of vacuum technology in most widely differing applications.



TVD pump system, mobile with control cabinet

The product is no longer in the foreground, solutions to problems are demanded instead.

Leybold has developed some continuously operating vacuum pump systems for these applications. These systems basically consist of a rotary vane pump with a condenser unit. Upon request the condenser arrangement may also be equipped with a cold water set. This version will then be independent of any cooling water connections and - being a mobile system - it is well-suited for operation at varying locations.

Products

Oil Sealed RUTA Pump Systems – Three-Stage, with Two-Stage TRIVAC Backing Pumps, Adaptor Version



RUTA WAU501/D65B/A

Standard Equipment

- Exhaust filter
- Oil collecting pan
- Manually operated gas ballast
- Crane eyes on the frame
- Floor mounting
- The oil is supplied with the pump
- CE approval

Options

- Frequency converter RUVATRONIC RT for controlling the speed of the Roots pump
- Oil filter
- 24 V DC gas ballast valve
- Sound proofing box
- Vibration absorbers
- Castors
- Different types of floor mounts
- Oil drain valve on each pump
- Exhaust filter with oil return line
- Special motors
- Electric control systems

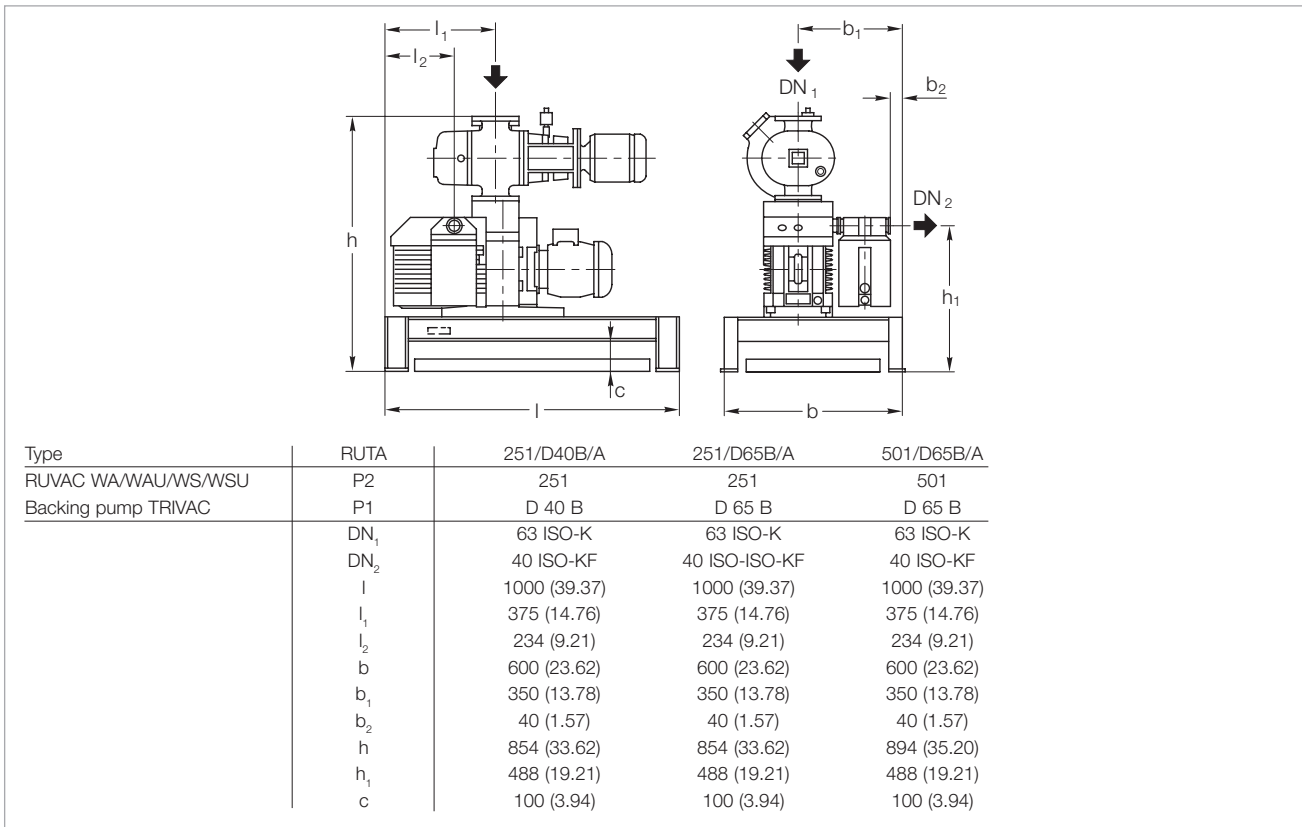

Dimensional drawing for the pump systems with TRIVAC D40/65 B backing pumps on pallet; dimensions in brackets () are in inch

Technical Data, 50 Hz

RUTA WAU

		251/D40B/A	251/D65B/A	501/D65B/A
RUVAC (WA/WAU/WS/WSU possible)	P2	251	251	501
Backing pump TRIVAC	P1	D 40 B	D 65 B	D 65 B
Pumping speed, 50 Hz at 10 ⁻¹ mbar (7.5 x 10 ⁻² Torr)	m ³ /h (cfm)	200.0 (117.8)	210.0 (123.7)	380.0 (223.8)
Ultimate partial pressure	mbar (Torr)	< 2 x 10 ⁻⁵ (< 1.5 x 10 ⁻⁵)	< 2 x 10 ⁻⁵ (< 1.5 x 10 ⁻⁵)	< 2 x 10 ⁻⁵ (< 1.5 x 10 ⁻⁵)
Ultimate total pressure with gas ballast	mbar (Torr)	< 8 x 10 ⁻⁴ (< 6 x 10 ⁻⁴)	< 8 x 10 ⁻⁴ (< 6 x 10 ⁻⁴)	< 8 x 10 ⁻⁴ (< 6 x 10 ⁻⁴)
Installed motor power 400 V, 50 Hz	kW (hp)	2.6 (3.5)	3.3 (4.5)	4.4 (6.0)
Electrical power consumption at 10 ⁻¹ mbar (7.5 x 10 ⁻² Torr)	kW (hp)	2.0 (2.7)	2.5 (3.4)	2.7 (3.7)
Noise level				
max.	dB(A)	64	65	67
without gas ballast at 1 mbar (0.75 Torr)	dB(A)	62	63	63
Oil filling, total, approx.	l (qt)	3.3 (3.49)	4.0 (4.23)	4.3 (4.55)
Weight, total, approx.	kg (lbs)	245.0 (540.2)	260.0 (573.3)	305.0 (627.5)
Connecting flange				
Inlet port	DN ₁	63 ISO-K	63 ISO-K	63 ISO-K
Outlet port	DN ₂	40 ISO-KF	40 ISO-KF	40 ISO-KF

Ordering Information

RUTA WAU

		251/D40B/A	251/D65B/A	501/D65B/A
		Part No.	Part No.	Part No.
RUVAC (WA/WAU/WS/WSU possible)	P2	WAU 251	WAU 251	WAU 501
Backing pump TRIVAC	P1	D 40 B	D 65 B	D 65 B
Pump system, complete (adaptor version), pallet mounted, with Roots vacuum pump RUVAC WAU		023 06	023 07	023 08
Frequency converter RUVATRONIC (see description in Chapter "Accessories")		RT 5/251 500 001 381	RT 5/251 500 001 381	RT 5/501 500 001 382

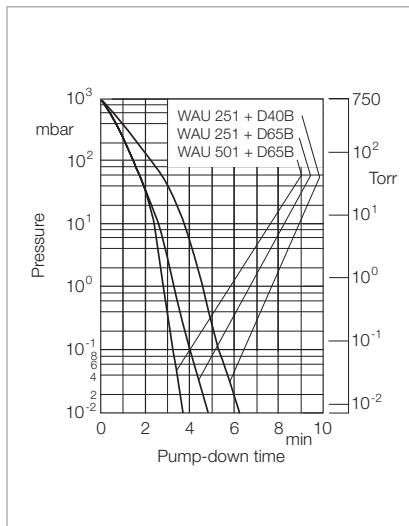

Pump-down time diagram for a 1000 l tank at 50 Hz

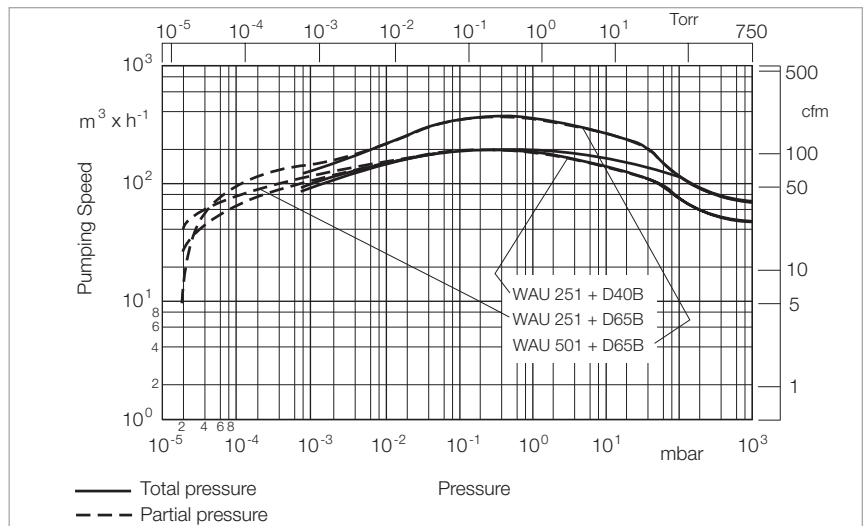

Pumping speed diagram at 50 Hz

Oil Sealed RUTA Pump Systems – Three-Stage, with Two-Stage TRIVAC Backing Pumps, Frame Version

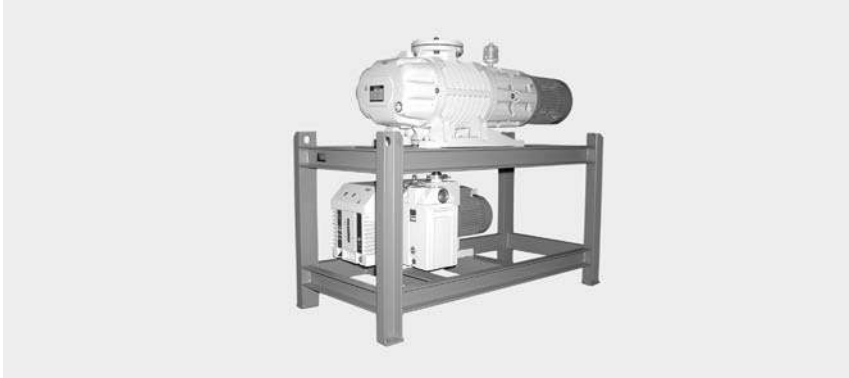

RUTA WAU501/D65B/G

Standard Equipment

- Exhaust filter
- Oil collecting pan
- Manually operated gas ballast
- Crane eyes on the frame
- Floor mounting
- The oil is supplied with the pump
- CE approval

Options

- Frequency converter RUVATRONIC RT for controlling the speed of the Roots pump
- Oil filter
- 24 V DC gas ballast valve
- Sound proofing box
- Vibration absorbers
- Castors
- Different types of floor mounts
- Oil drain valve on each pump
- Exhaust filter with oil return line
- Special motors
- Electric control systems

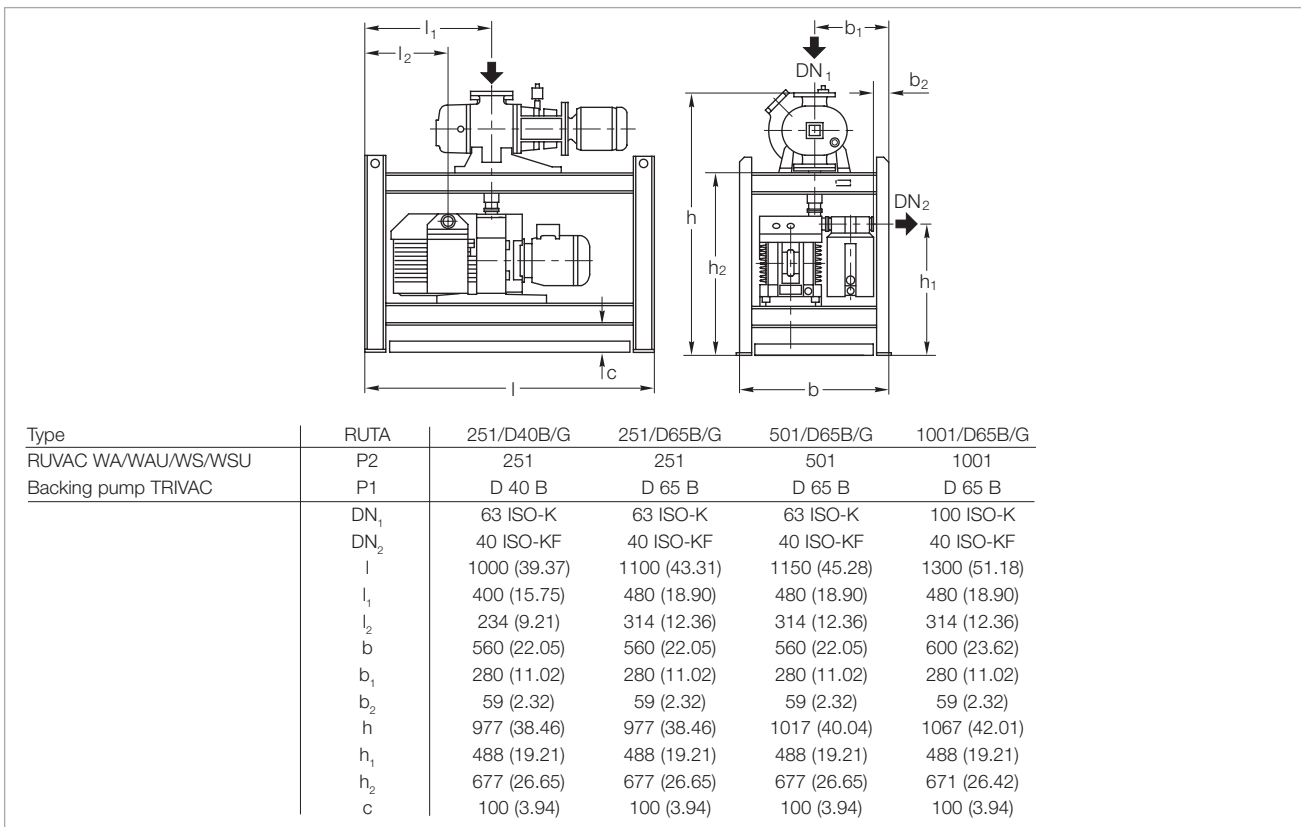

Dimensional drawing for the pump systems with TRIVAC D40/65 B backing pumps in a frame; dimensions in brackets () are in inch

Technical Data, 50 Hz

RUTA WAU

		251/D40B/G	251/D65B/G	501/D65B/G	1001/D65B/G
RUVAC (WA/WAU/WS/WSU possible)	P2	251	251	501	1001
Backing pump TRIVAC	P1	D 40 B	D 65 B	D 65 B	D 65 B
Pumping speed, 50 Hz at 10^{-1} mbar (7.5×10^{-2} Torr)	m^3/h (cfm)	185.0 (109.0)	205.0 (120.7)	340.0 (200.3)	620.0 (365.2)
Ultimate partial pressure	mbar (Torr)	$< 2 \times 10^{-5}$ ($< 1.5 \times 10^{-5}$)	$< 2 \times 10^{-5}$ ($< 1.5 \times 10^{-5}$)	$< 2 \times 10^{-5}$ ($< 1.5 \times 10^{-5}$)	$< 2 \times 10^{-5}$ ($< 1.5 \times 10^{-5}$)
Ultimate total pressure with gas ballast	mbar (Torr)	$< 8 \times 10^{-4}$ ($< 6 \times 10^{-4}$)	$< 8 \times 10^{-4}$ ($< 6 \times 10^{-4}$)	$< 8 \times 10^{-4}$ ($< 6 \times 10^{-4}$)	$< 8 \times 10^{-4}$ ($< 6 \times 10^{-4}$)
Installed motor power 400 V, 50 Hz	kW (hp)	2.6 (3.5)	3.3 (4.5)	4.4 (6.0)	6.2 (8.4)
Electrical power consumption at 10^{-1} mbar (7.5×10^{-2} Torr)	kW (hp)	2.0 (2.7)	2.5 (3.4)	2.7 (3.7)	3.0 (4.1)
Noise level max. without gas ballast at 1 mbar (0.75 Torr)	dB(A)	64	65	67	77
	dB(A)	62	63	63	70
Oil filling, total, approx.	l (qt)	3.3 (4.5)	4.0 (4.23)	4.3 (4.55)	5.3 (5.60)
Weight, total, approx.	kg (lbs)	280.0 (617.4)	310.0 (683.6)	350.0 (771.8)	460.0 (1014.3)
Connecting flange Inlet port	DN ₁	63 ISO-K	63 ISO-K	63 ISO-K	100 ISO-K
Outlet port	DN ₂	40 ISO-KF	40 ISO-KF	40 ISO-KF	40 ISO-KF

Ordering Information

RUTA WAU

		251/D40B/G	251/D65B/G	501/D65B/G	1001/D65B/G
		Part No.	Part No.	Part No.	Part No.
RUVAC (WA/WAU/WS/WSU possible)	P2	WAU 251	WAU 251	WAU 501	WAU 1001
Backing pump TRIVAC	P1	D 40 B	D 65 B	D 65 B	D 65 B
Pump system, complete (frame version), frame mounted, with Roots vacuum pump RUVAC WAU		023 16	023 17	023 18	023 19
Frequency converter RUVATRONIC (see description in Chapter "Accessories")		RT 5/251 500 001 381	RT 5/251 500 001 381	RT 5/501 500 001 382	RT 5/1001 500 001 383

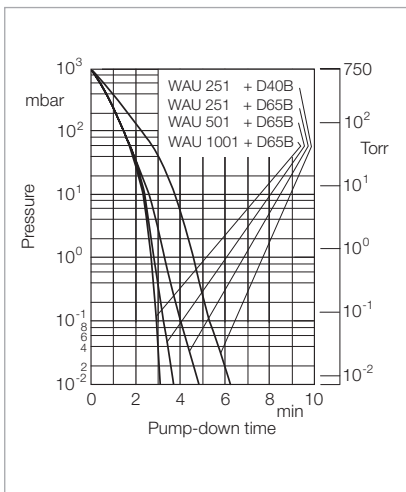

Pump-down time diagram for a 1000 l tank at 50 Hz

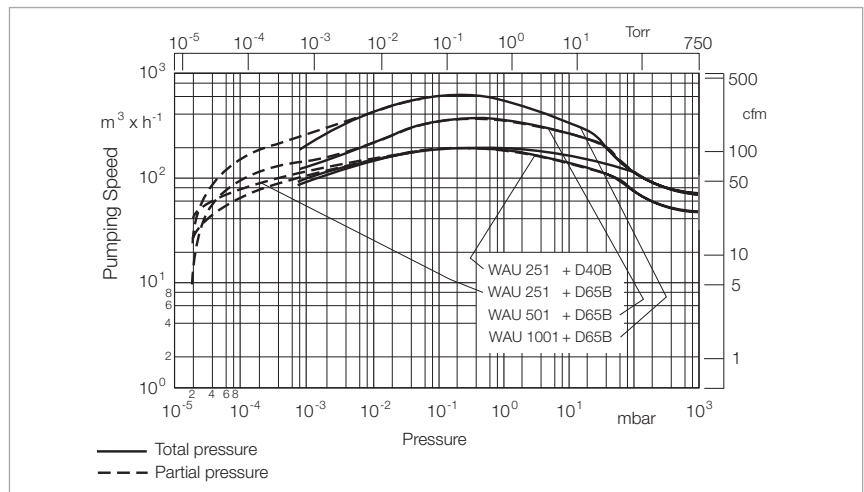

Pumping speed diagram at 50 Hz

Oil Sealed RUTA Pump Systems – Two-Stage, with Single-Stage SOGEVAC Backing Pumps, Adaptor Version

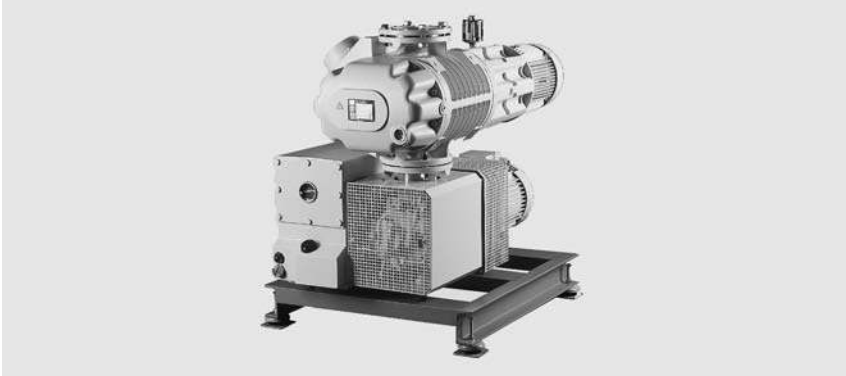

RUTA WAU1001/SV200/A

Standard Equipment

- Exhaust filter with oil return line
- Oil filter
- Oil collecting pan
- Gas ballast valve:
SV 200/300 B manually operated
SV 630 BF 24 V DC
- SV 200/300 B with air cooling
- SV 630 BF with water cooling
- Floor mounting

- The oil is supplied with the pump
- CE approval

Options

- Frequency converter
RUVATRONIC RT for controlling the speed of the Roots pump
- 24 V DC gas ballast valve or manually operated

- Sound proofing box
- Vibration absorbers
- Castors
- Different types of floor mounts
- Oil drain valve on each pump
- Special motors
- Electric control systems

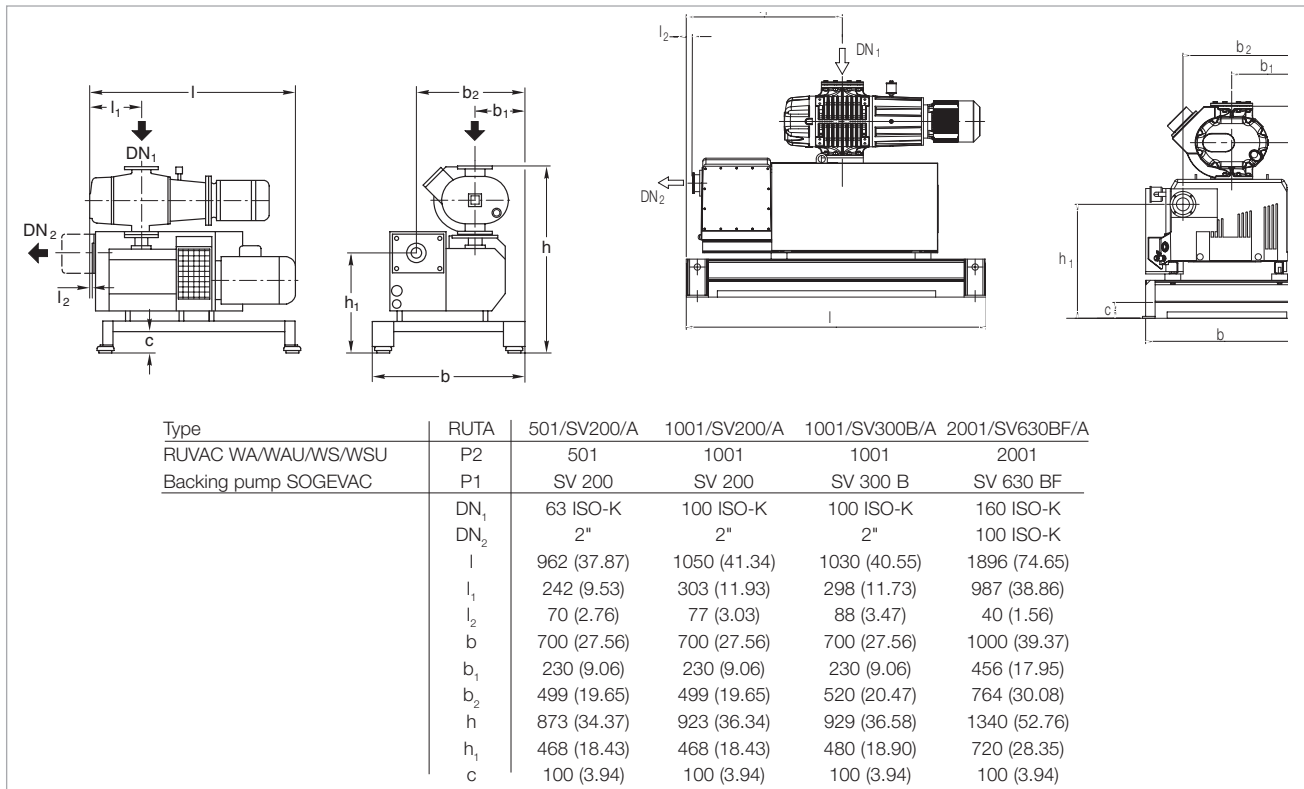

Dimensional drawing for the pump systems with SOGEVAC SV 200 and 300 B backing pumps [left], SOGEVAC SV 630 BF [right]; dimensions in brackets () are in inch

Technical Data, 50 Hz

RUTA WAU

501/SV200/A 1001/SV200/A 1001/SV300B/A 2001/SV630BF/A

RUVAC (WA/WAU/WS/WSU possible)	P2	501	1001	1001	2001
Backing pump SOGEVAC	P1	SV 200	SV 200	SV 300 B	SV 630 BF
Pumping speed, 50 Hz at 10^{-1} mbar (7.5×10^{-2} Torr)	m^3/h (cfm)	365.0 (215.0)	715.0 (421.0)	730.0 (430.0)	1690.0 (995.4)
Ultimate partial pressure	mbar (Torr)	$< 8 \times 10^{-3}$ ($< 6 \times 10^{-3}$)	$< 8 \times 10^{-3}$ ($< 6 \times 10^{-3}$)	$< 8 \times 10^{-3}$ ($< 6 \times 10^{-3}$)	$< 8 \times 10^{-3}$ ($< 6 \times 10^{-3}$)
Ultimate total pressure with gas ballast	mbar (Torr)	$< 4 \times 10^{-2}$ ($< 3 \times 10^{-2}$)	$< 4 \times 10^{-2}$ ($< 3 \times 10^{-2}$)	$< 4 \times 10^{-2}$ ($< 3 \times 10^{-2}$)	$< 4 \times 10^{-2}$ ($< 3 \times 10^{-2}$)
Installed motor power 400 V, 50 Hz	kW (hp)	6.2 (8.4)	8.0 (10.9)	9.5 (12.9)	22.5 (30.6)
Electrical power consumption at 10^{-1} mbar (7.5×10^{-2} Torr)	kW (hp)	3.0 (4.1)	3.5 (4.8)	4.0 (5.4)	16.5 (22.4)
Noise level without gas ballast at 10^{-1} mbar (7.5×10^{-2} Torr)	dB(A)	70	75	76	80
Oil filling, total, approx.	l (qt)	6.0 (6.34)	7.0 (7.4)	11.0 (11.63)	26.0 (27.47)
Weight, total, approx.	kg (lbs)	335.0 (738.7)	430.0 (948.2)	480.0 (1058.4)	1140.0 (2513.7)
Connecting flange					
Inlet port	DN ₁	63 ISO-K	100 ISO-K	100 ISO-K	160 ISO-K
Outlet port	DN ₂	2"	2"	2"	100 ISO-K

Ordering Information

RUTA WAU

501/SV200/A 1001/SV200/A 1001/SV300B/A 2001/SV630BF/A

		Part No.	Part No.	Part No.	Part No.
RUVAC (WA/WAU/WS/WSU possible)	P2	WAU 501	WAU 1001	WAU 1001	WAU 2001
Backing pump SOGEVAC	P1	SV 200	SV 200	SV 300 B	SV 630 BF
Pump system, complete (adaptor version), pallet mounted, with Roots vacuum pump RUVAC WAU		022 06	022 08	502 462 V001	502 463 V001
Frequency converter RUVATRONIC (see description in Chapter "Accessories")		RT 5/501	RT 5/1001	RT 5/1001	RT 5/2001
		500 001 382	500 001 383	500 001 383	500 001 384

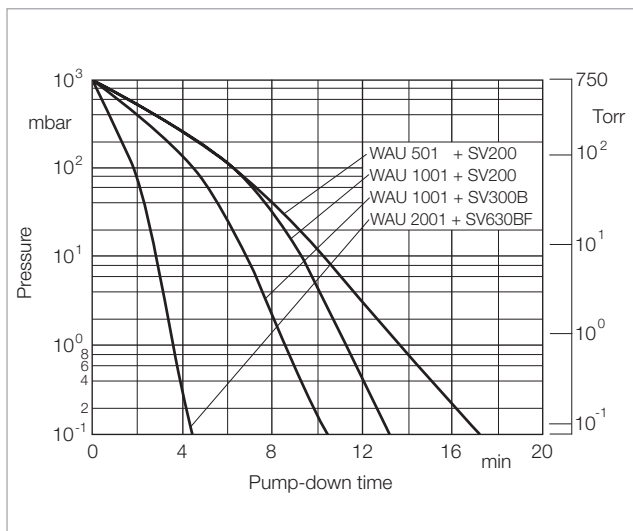

Pump-down time diagram for a 10 m³ tank at 50 Hz

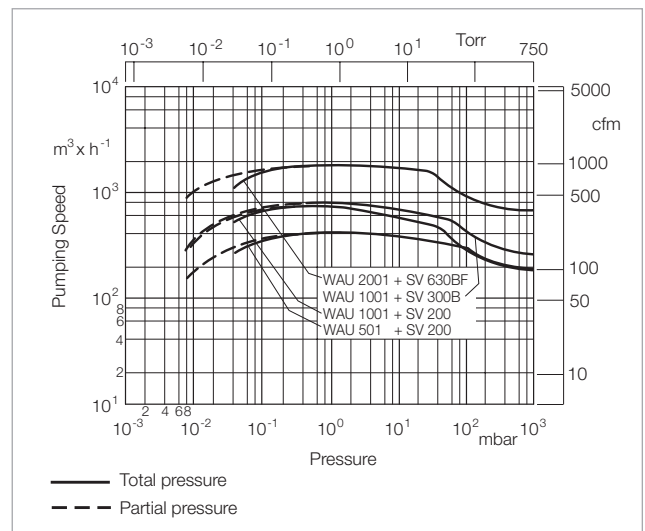

Pumping speed diagram at 50 Hz

Oil Sealed RUTA Pump Systems – Two-Stage, with Single-Stage SOGEVAC Backing Pumps, Adaptor Version

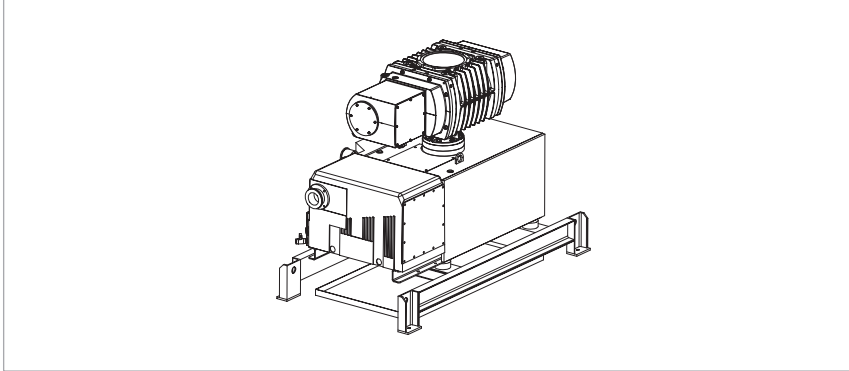

RUTA WH4400/SV630BF/A

Standard Equipment

- RUVAC WH with water cooling
- Exhaust filter with oil return line
- Oil filter
- Oil collecting pan
- Gas ballast valve:
SV 100 to 300 manually operated
SV 630 BF 24 V DC
- SV 100 to 300 with air cooling
- SV 630 BF with water cooling

- Floor mounting
- The oil is supplied with the pump
- RUVAC WH including external frequency converter (frequency converter permits pumping speed control)
- CE approval

Options

- 24 V DC gas ballast valve or manually operated
- Sound proofing box
- Vibration absorbers
- Castors
- Different types of floor mounts
- Oil drain valve on each pump
- Special motors
- Electric control systems

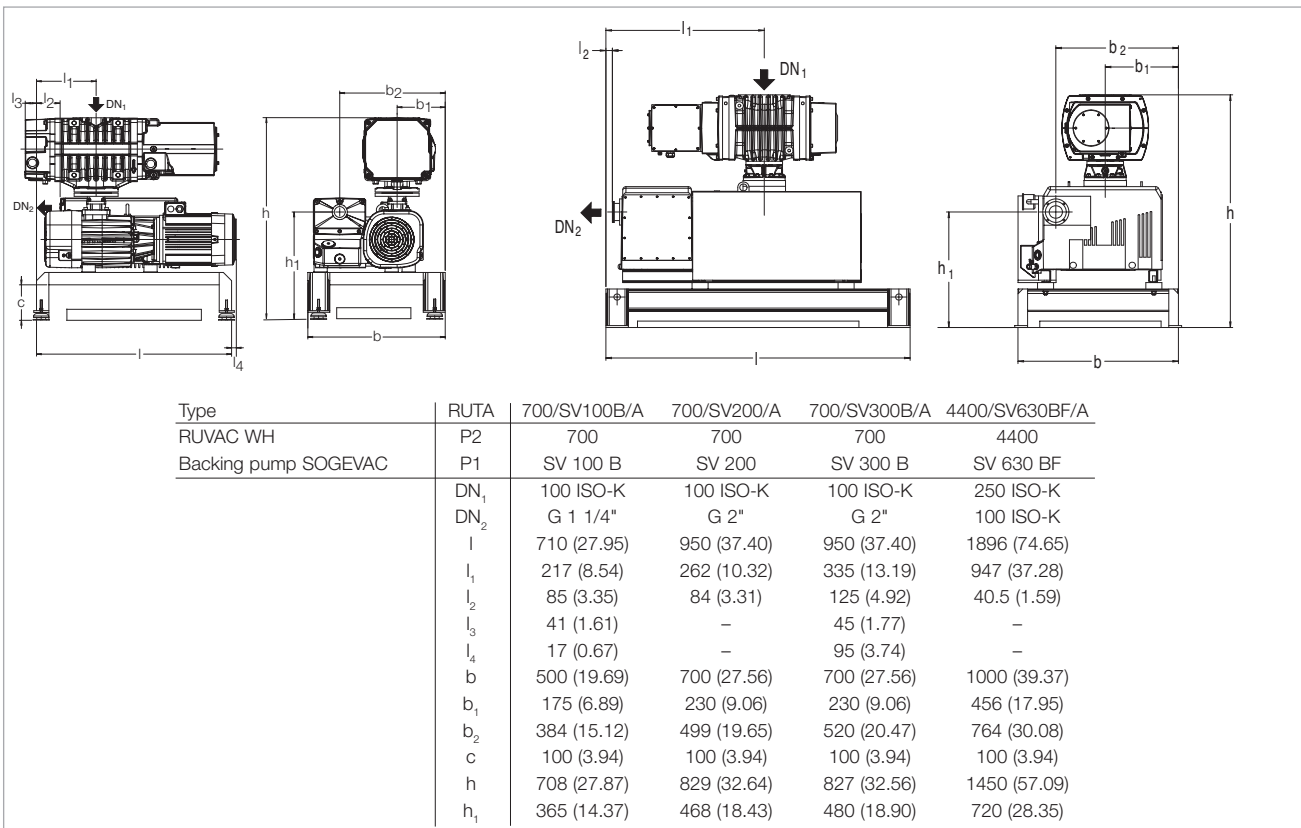

Dimensional drawing for the pump systems with SOGEVAC SV 100 B, 200 and 300 B backing pumps [left], SOGEVAC SV 630 BF [right]; dimensions in brackets () are in inch

Technical Data, 50 Hz

RUTA WH

		700/SV100B/A	700/SV200/A	700/SV300B/A	4400/SV630BF/A
RUVAC WH	P2	700	700	700	4400
Backing pump SOGEVAC	P1	SV 100 B	SV 200	SV 300 B	SV 630 BF
Pumping speed, 50 Hz at 10^{-1} mbar (7.5×10^{-2} Torr)	m ³ /h (cfm)	520 (306)	570 (335)	600 (353)	3332 (1961)
Ultimate pressure without gas ballast	mbar (Torr)	$< 5 \times 10^{-3}$ ($< 3.75 \times 10^{-3}$)	$< 2 \times 10^{-3}$ ($< 1.5 \times 10^{-3}$)	$< 3 \times 10^{-3}$ ($< 2.25 \times 10^{-3}$)	$< 3 \times 10^{-3}$ ($< 2.25 \times 10^{-3}$)
Installed motor power 400 V, 50 Hz	kW (hp)	4.4 (5.9)	6.2 (8.3)	7.7 (10.3)	26.0 (34.9)
Electrical power consumption at 10^{-1} mbar (7.5×10^{-2} Torr)	kW (hp)	1.6 (2.2)	2.9 (3.9)	6.0 (8.0)	9,68 (12.98)
Noise level at 10^{-1} mbar (7.5×10^{-2} Torr)	dB(A)	62	69	70	73
Oil filling, total, approx.	l (qt)	2.9 (2.6)	9.9 (8.7)	12.4 (10.9)	27.0 (23.8)
Weight, approx.	kg (lbs)	350 (722)	415 (915)	465 (1025)	1 330 (2932)
Connecting flange					
Inlet port	DN ₁	100 ISO-K	100 ISO-K	100 ISO-K	250 ISO-K
Outlet port	DN ₂	G 1 1/4"	G 2"	G 2"	100 ISO-K

Ordering Information

RUTA WH

		700/SV100B/A	700/SV200/A	700/SV300B/A	4400/SV630BF/A
RUVAC WH	P2	700	700	700	4400
Backing pump SOGEVAC					
air-cooled	P1	SV 100 B	SV 200	SV 300 B	-
water-cooled	P1	-	-	-	SV 630 BF
Pump system, complete (adaptor version), pallet mounted, with Roots vacuum pump RUVAC WH		503155V001 ¹⁾	503156V001 ¹⁾	503157V001 ¹⁾	503164V001 ¹⁾

¹⁾ Including external frequency converter

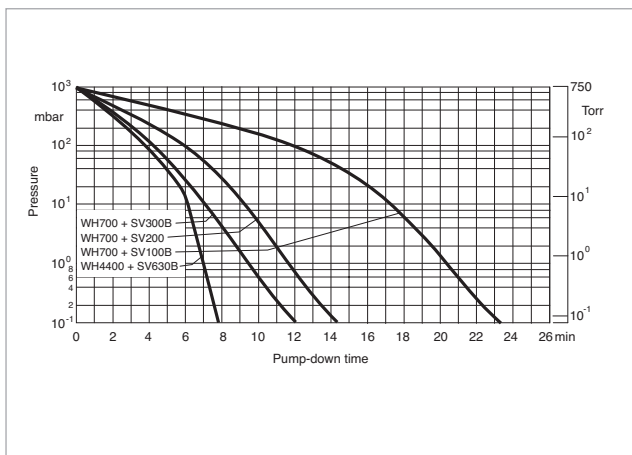

Pump-down time diagram for a 10 m³ tank at 50 Hz

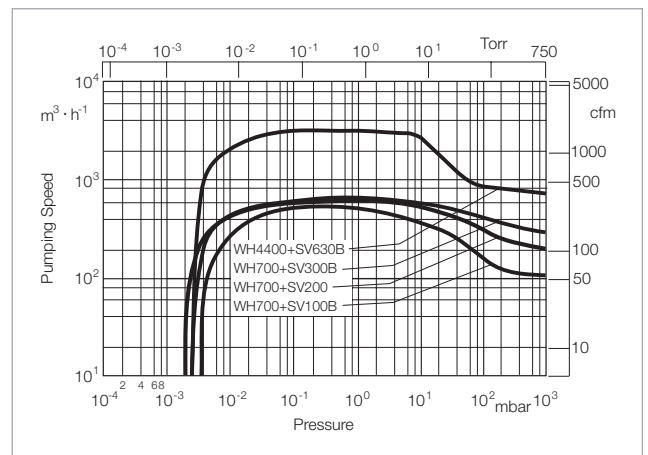

Pumping speed diagram at 50 Hz

Oil Sealed RUTA Pump Systems – Two-Stage, with Single-Stage SOGEVAC Backing Pumps, Frame Version

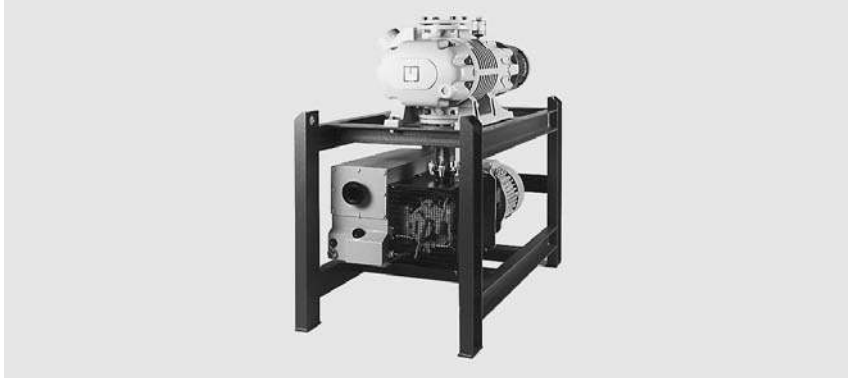

RUTA WAU2001/SV300B/G

Standard Equipment

- RUVAC WAU with air cooling
- SOGEVAC SV 300 B with air cooling
- Exhaust filter with oil return line
- Oil filter
- Oil collecting pan
- Gas ballast valve: SV 300 B manually operated
- Crane eyes on the frame
- Floor mounting

- The oil is supplied with the pump
- CE approval

Options

- Frequency converter RUVATRONIC RT for controlling the speed of the Roots pump
- 24 V DC gas ballast valve or manually operated
- Sound proofing box

- Vibration absorbers
- Castors
- Different types of floor mounts
- Oil drain valve on each pump
- Special motors
- Electric control systems

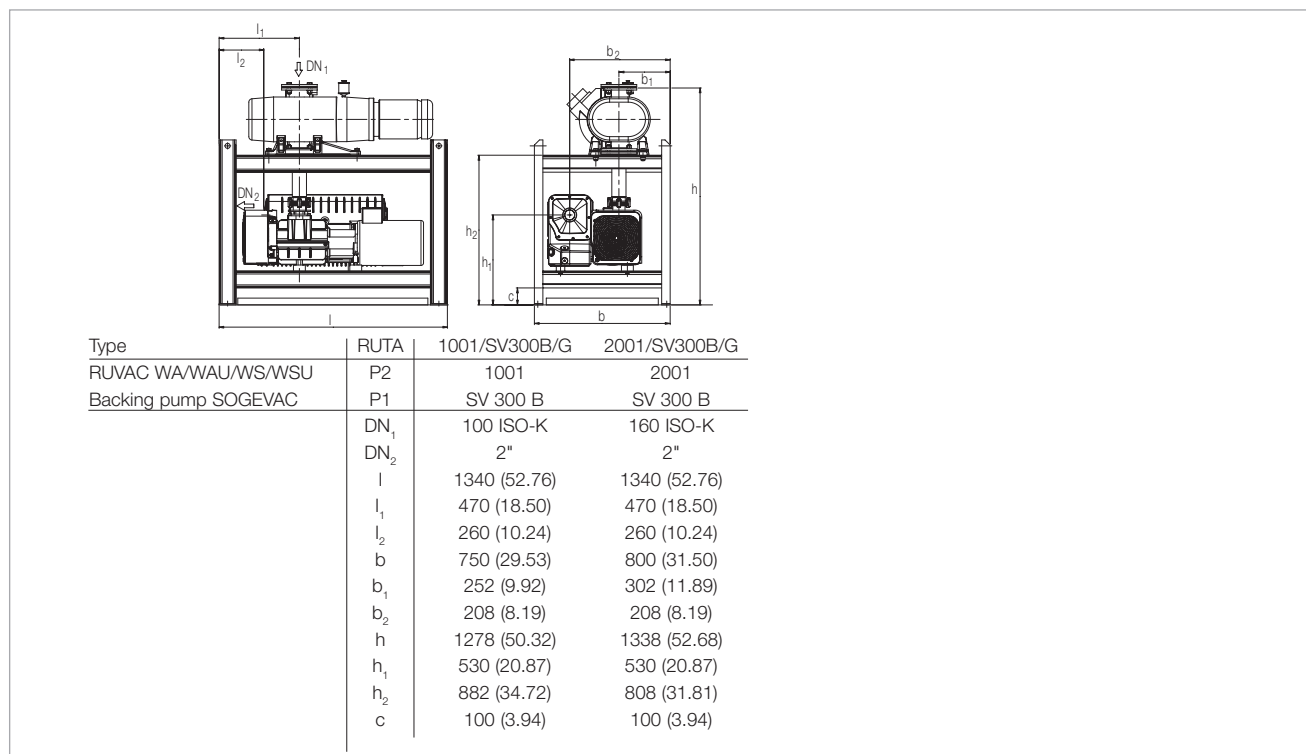

Dimensional drawing for the pump systems with SOGEVAC SV 300 B backing pumps; dimensions in brackets () are in inch

Technical Data, 50 Hz

RUTA WAU

1001/SV300B/G

2001/SV300B/G

RUVAC (WA/WAU/WS/WSU possible)	P2	1001	2001
Backing pump SOGEVAC	P1	SV 300 B	SV 300 B
Pumping speed, 50 Hz at 10^{-1} mbar (7.5×10^{-2} Torr)	m ³ /h (cfm)	730 (430)	1445 (850)
Ultimate partial pressure	mbar (Torr)	$< 8 \times 10^{-3}$ ($< 6 \times 10^{-3}$)	$< 8 \times 10^{-3}$ ($< 6 \times 10^{-3}$)
Ultimate total pressure with gas ballast	mbar (Torr)	$< 4 \times 10^{-2}$ ($< 3 \times 10^{-2}$)	$< 4 \times 10^{-2}$ ($< 3 \times 10^{-2}$)
Installed motor power 400 V, 50 Hz	kW (hp)	9.5 (12.9)	13.0 (17.7)
Electrical power consumption at 10^{-1} mbar (7.5×10^{-2} Torr)	kW (hp)	4.0 (5.4)	4.5 (6.1)
Noise level without gas ballast at 10^{-1} mbar (7.5×10^{-2} Torr)	dB(A)	75	79
Oil filling, total, approx.	l (qt)	11 (11.63)	13 (13.74)
Weight, total, approx.	kg (lbs)	560.0 (1234.8)	740.0 (1631.7)
Connecting flange			
Inlet port	DN ₁	100 ISO-K	160 ISO-K
Outlet port	DN ₂	2"	2"

Ordering Information

RUTA WAU

1001/SV300B/G

2001/SV300B/G

		Part No.	Part No.
RUVAC (WA/WAU/WS/WSU possible)	P2	WAU 1001	WAU 2001
Backing pump SOGEVAC	P1	SV 300 B	SV 300 B
Pump system, complete (frame version), frame mounted, with Roots vacuum pump RUVAC WAU		502 452 V001	502 453 V001
Frequency converter RUVATRONIC (see description in Chapter "Accessories")		RT 5/1001 500 001 383	RT 5/2001 500 001 384

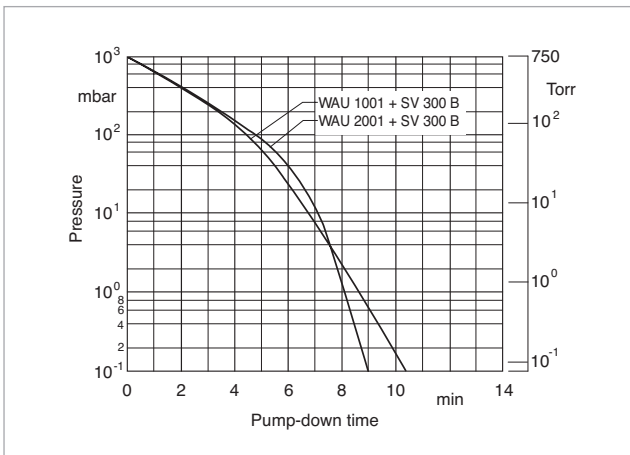

Pump-down time diagram for a 10 m³ tank at 50 Hz

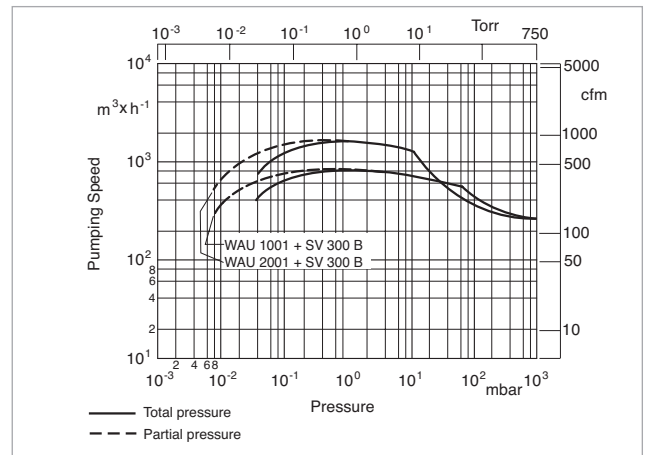

Pumping speed diagram at 50 Hz

Oil Sealed RUTA Pump Systems – Two-Stage, with Single-Stage SOGEVAC Backing Pumps, Frame Version

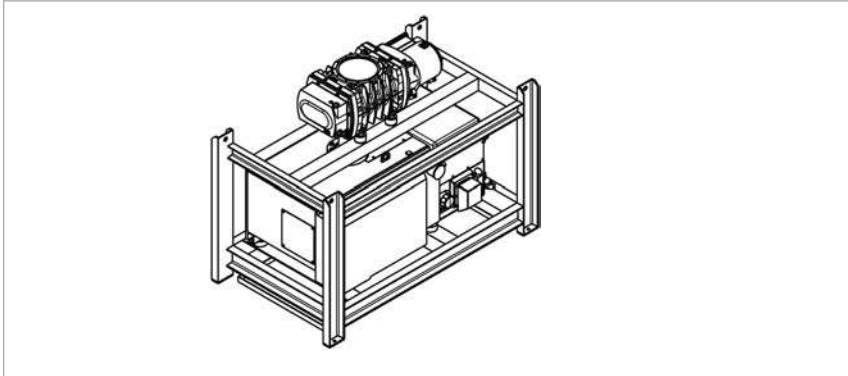

RUTA WH2500/SV630BF/G

Standard Equipment

- RUVAC WH with water cooling
- Exhaust filter with oil return line
- Oil filter
- Oil collecting pan
- Gas ballast valve: SOGEVAC SV 630 BF 24 V DC
- SOGEVAC SV 630 BF with water cooling
- SOGEVAC SV 1200 with air cooling
- Crane eyes on the frame
- Floor mounting
- The oil is supplied with the pump
- RUVAC WH including external frequency converter (frequency converter permits pumping speed control)
- CE approval

Options

- Frequency converter for controlling the speed of the Roots pump (only RUVAC WA/WS)
- 24 V DC gas ballast valve or manually operated
- Sound proofing box
- Vibration absorbers
- Castors
- Different types of floor mounts
- Oil drain valve on each pump
- Special motors
- Electric control systems

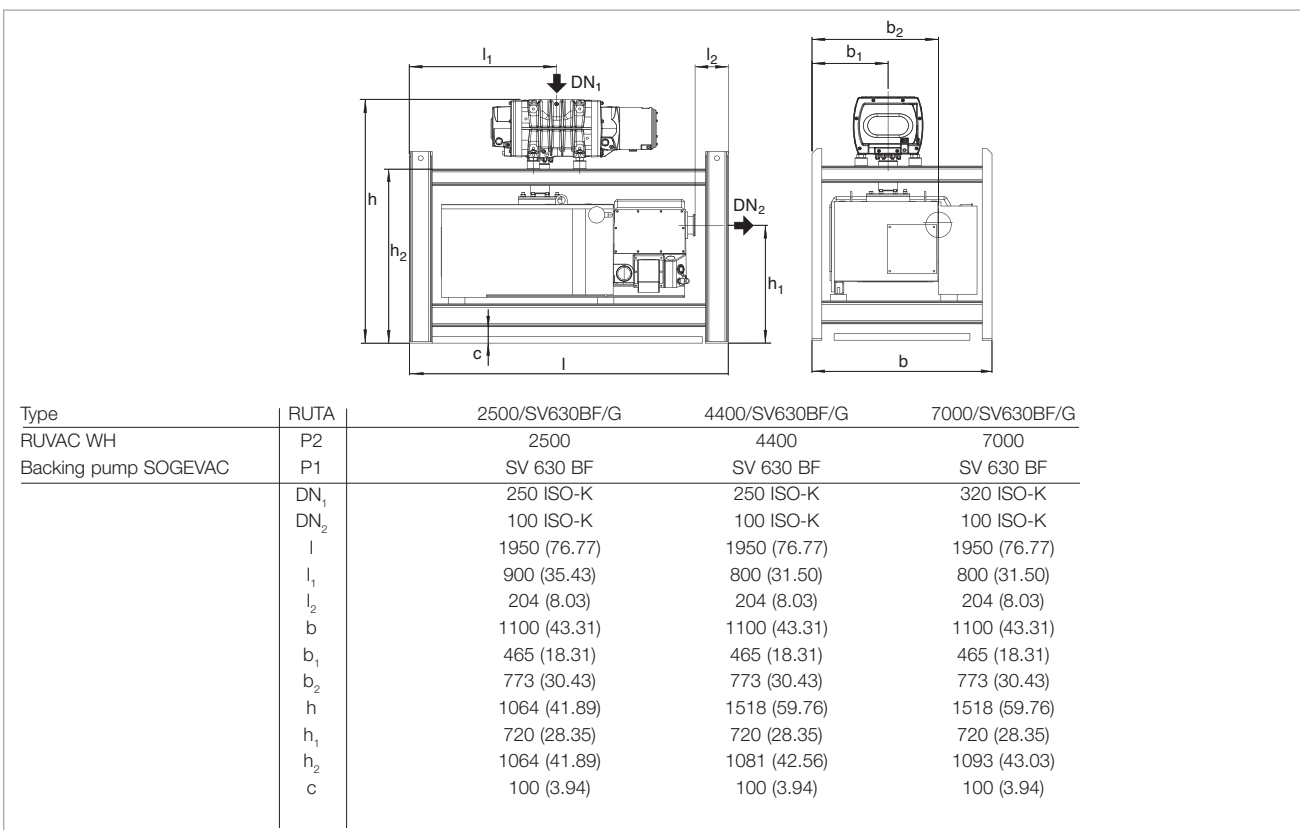

Dimensional drawing for the pump systems with SOGEVAC SV backing pumps

Technical Data, 50 Hz

		RUTA		
		WH 2500/ SV630BF/G	WH 4400/ SV630BF/G	WH 7000/ SV630BF/G
RUVAC WH ¹⁾	P2	2500	4400	7000
Backing pump SOGEVAC	P1	SV 630 BF	SV 630 BF	SV 630 BF
Pumping speed, 50 Hz at 10 ⁻¹ mbar (7.5 x 10 ⁻² Torr)	m ³ /h (cfm)	1902 (1119)	3332 (1961)	4990 (2937)
Ultimate total pressure with gas ballast	mbar	< 5 x 10 ⁻³	-	-
	(Torr)	(< 3.7 x 10 ⁻³)	-	-
without gas ballast	mbar	-	< 5 x 10 ⁻³	< 5 x 10 ⁻³
	(Torr)	-	(< 3.7 x 10 ⁻³)	(< 3.7 x 10 ⁻³)
Installed motor power 400 V, 50 Hz	kW (hp)	21.5 (28.8)	26.0 (34.9)	26.0 (34.9)
Electrical power consumption at 10 ⁻¹ mbar (7.5 x 10 ⁻² Torr)	kW (hp)	8.5 (11.4)	9.68 (12.98)	9.84 (13.20)
Noise level without gas ballast at 10 ⁻¹ mbar (7.5 x 10 ⁻² Torr)	dB(A)	73	73	73
Oil filling, total, approx.	l (qt)	16.2 (17.1)	27.0 (4.6)	27.0 (4.6)
Weight, total, approx.	kg (lbs)	1360 (2998)	1530 (3373)	1590 (3505)
Connecting flange				
Inlet port	DN ₁	250 ISO-K	250 ISO-K	320 ISO-K
Outlet port	DN ₂	100 ISO-K	100 ISO-K	100 ISO-K

Ordering Information

		RUTA		
		WH 2500/ SV630BF/G	WH 4400/ SV630BF/G	WH 7000/ SV630BF/G
		Part No.	Part No.	Part No.
RUVAC WH ¹⁾	P2	2500	4400	7000
Backing pump SOGEVAC	P1	SV 630 BF	SV 630 BF	SV 630 BF
Pump system, complete (frame version), frame mounted, with Roots vacuum pump RUVAC WH		503161V001 ^{1, 2)}	503161V001 ^{1, 2)}	503161V001 ^{1, 2)}

¹⁾ Including external frequency converter

²⁾ With this combination, continuous operation of the Roots pump is not possible at atmospheric pressure

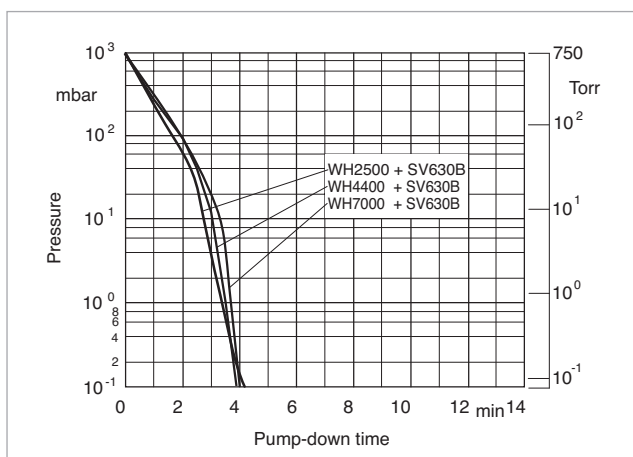

Pump-down time diagram for a 10 m³ tank at 50 Hz

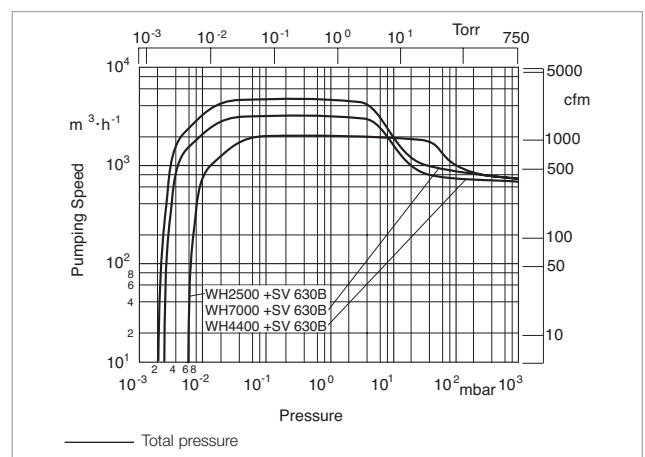

Pumping speed diagram at 50 Hz

Pump Systems (Only available for purchase in North and South America)

RBS – B/BCS Roots Pump Systems with Two-Stage TRIVAC Backing Pumps



RBS - B/BCS Roots pumping system, shown with optional AF exhaust filter

Standard Equipment

- System consists of TRIVAC dual-stage B or BCS direct drive vane pump and RUVAC blower
- Complete air-cooled system
- 18" wide frame base equipped with caster wheels and leveling pads
- Compact construction with quiet operation
- Manual operation of gas ballast
- Close-coupled RUVAC blower with ANSI inlet flange

Options

- All TRIVAC accessories, Exhaust filter, 24 V DC gas ballast valve, chemical oil filter, and electrical limit switch system
- Full frame drip pan
- Oil drain valves
- Special motor voltages and frequencies
- Special oil for unique applications
- Full electrical controls for control start/stop and monitoring of system

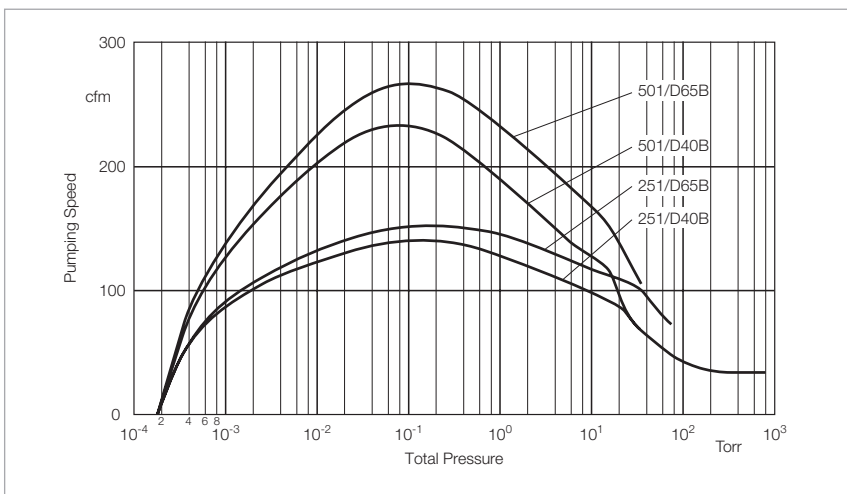

Pumping speed diagram for the RBS systems with WSU series Roots blowers at 60 Hz

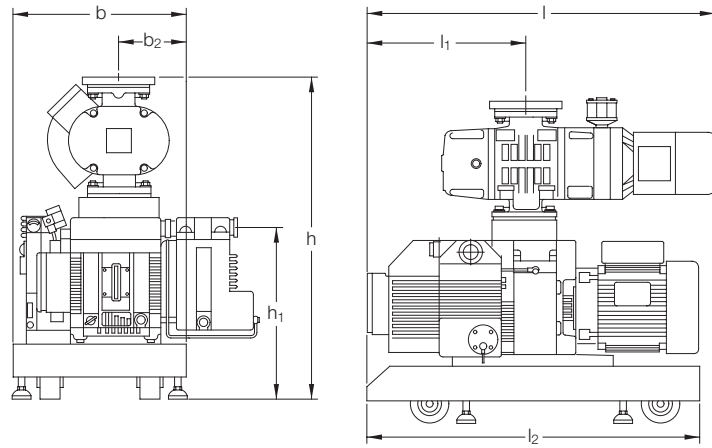

System	b	b ₁	b ₂	h	h ₁	l	l ₁	l ₂
Close-coupled								
D 40 B/BCS								
WSU 251	18 (457)	8 (203)	7 (178)	33 3/16 (853)	17 15/16 (456)	32 3/4 (832)	14 (356)	34 (864)
WSU 501	18 (457)	8 (203)	7 (178)	34 3/4 (883)	17 15/16 (456)	33 13/16 (859)	14 (356)	34 (864)
D 65 B/BCS								
WS/WSU 251	18 (457)	8 (203)	7 (178)	33 3/16 (853)	17 15/16 (456)	34 3/4 (883)	16 (406)	34 (864)
WS/WSU 501	18 (457)	8 (203)	7 (178)	34 3/4 (883)	17 15/16 (456)	35 13/16 (910)	16 (406)	34 (864)

Dimensional drawing for the RBS – B/BCS Roots pumping systems 18" with TRIVAC D 40/65 B backing pumps, close-coupled package; dimensions in brackets () are in mm

Technical Data

RBS – B/BCS Roots Pump Systems

		251/D40B	251/D65B	501/D40B	501/D65B
RUVAC (WA/WAU/WS/WSU possible)		251	251	501	501
TRIVAC backing pump		D 40 B/BCS	D 65 B/BCS	D 40 B/BCS	D 65 B/BCS
Pumping speed @ 0.1 Torr	cfm (m ³ /h)	140 (237)	150 (254)	232 (394)	267 (453)
Ultimate total pressure	Torr (mbar)	2 x 10 ⁻⁴ (< 4 x 10 ⁻⁴)	2 x 10 ⁻⁴ (< 4 x 10 ⁻⁴)	2 x 10 ⁻⁴ (< 4 x 10 ⁻⁴)	2 x 10 ⁻⁴ (< 4 x 10 ⁻⁴)
Connecting flanges					
Inlet port					
WSU	DN	3" ANSI	3" ANSI	3" ANSI	3" ANSI
Outlet port	DN	40 ISO-KF	40 ISO-KF	40 ISO-KF	40 ISO-KF
Operating voltage	V	208/230/460	208/230/460	208/230/460	208/230/460
Phase / Frequency ¹⁾	- / Hz	3 / 60	3 / 60	3 / 60	3 / 60
Full load amps ²⁾					
RUVAC WSU		5.5/5.5/3.2	5.5/5.5/3.2	9.0/9.0/5.2	9.0/9.0/5.2
TRIVAC		9.0/8.8/4.5	9.0/8.8/4.5	9.0/8.8/4.5	9.0/8.8/4.5
Displacement					
RUVAC	cfm (m ³ /h)	179 (304)	179 (304)	357 (606)	357 (606)
TRIVAC	cfm (m ³ /h)	32 (54)	53 (90)	32 (54)	53 (90)
Maximum differential pressure	Torr (mbar)	60 (80)	60 (80)	60 (80)	60 (80)
Normal starting pressure ³⁾	Torr (mbar)	20 (27)	30 (40)	12 (16)	16 (21)
Oil capacity					
RUVAC WSU	qt (l)	0.75 (0.7)	0.75 (0.7)	1.10 (1.0)	1.10 (1.0)
TRIVAC	qt (l)	2.70 (2.6)	3.40 (3.2)	2.70 (2.6)	3.40 (3.2)
Nominal rotation speed					
RUVAC	rpm (min ⁻¹)	3600 (3600)	3600 (3600)	3600 (3600)	3600 (3600)
TRIVAC	rpm (min ⁻¹)	1800 (1800)	1800 (1800)	1800 (1800)	1800 (1800)
Motor power					
RUVAC WSU	hp (kW)	1.9 (1.4)	1.9 (1.4)	3.3 (2.4)	3.3 (2.4)
TRIVAC	hp (kW)	3.0 (2.2)	3.0 (2.2)	3.0 (2.2)	3.0 (2.2)

Ordering Information

RBS – B/BCS Roots Pump Systems

	251/D40B	251/D65B	501/D40B	501/D65B
	Part. No.			
RBS – B/BCS Roots pump system (supplied with hydrocarbon oil)	Ordering Information see right page			

¹⁾ For 50 Hz systems, consult the factory

²⁾ Determined by operating voltage

³⁾ WSU pumps permit start-up at atmospheric pressure (760 Torr)

Ordering Information

Blower / TRIVAC pump
 WSU 251 / D 40 B
 WSU 251 / D 40 BCS-LVO 400
 WSU 251 / D 65 B
 WSU 251 / D 65 B-LVO 400
 WSU 501 / D 40 B
 WSU 501 / D 40 BCS-LVO 400
 WSU 501 / D 65 B
 WSU 501 / D 65 BCS-LVO 400

Reserved

Electrical Control Panel

None
 208 V
 230 V
 460 V

Part No. 180037V-

0

24

35

26

37

54

65

56

67

0

0

1

2

3

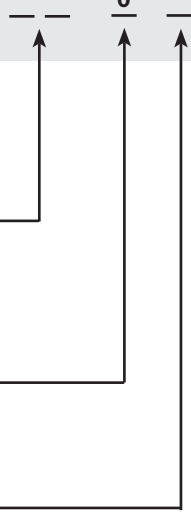

Pump Systems (Only available for purchase in North and South America)

HTS Close-Coupled Systems with Single-Stage SOGEVAC Backing Pumps

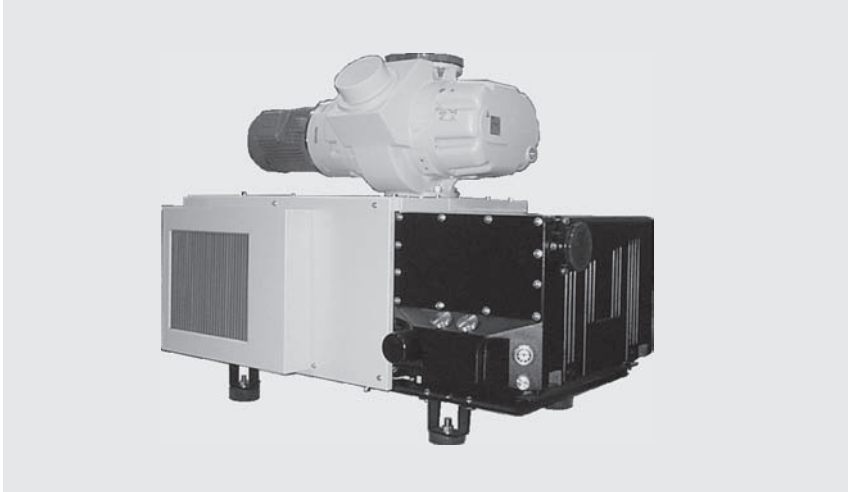

HTS close-coupled system

Standard Equipment

- System consists of single-stage SOGEVAC vane pump
- Complete air-cooled system
- Close-coupled RUVAC blower
- Compact construction with quiet operation
- Manual operation of gas ballast
- Spin-on type oil filter

Options

- SOGEVAC accessories: oil level monitoring, exhaust case gauge, 24 V DC gas ballast purge, water cooling
- Frame base mounted caster wheels
- Frame base mounted leveling pads
- Oil drain valves
- Inlet dust filter
- Special motor voltages and frequencies
- Special oil for unique applications
- Full NEMA12 electrical controls for stand/stop operation and monitoring of system from remote and local locations
- 24 V DC gas ballast valve

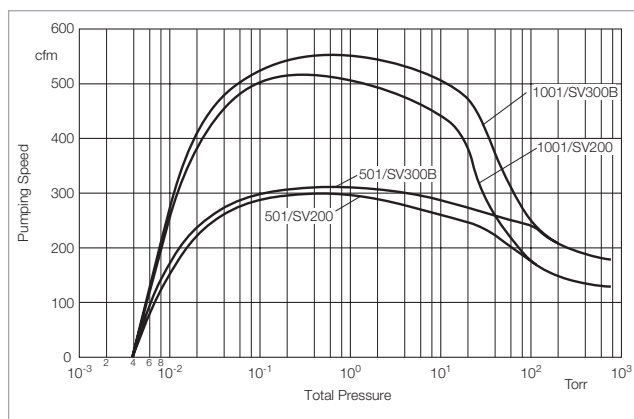

Pumping speed diagram for the HTS close-coupled systems with WSU series Roots blowers and SOGEVAC SV 200/300B at 60 Hz

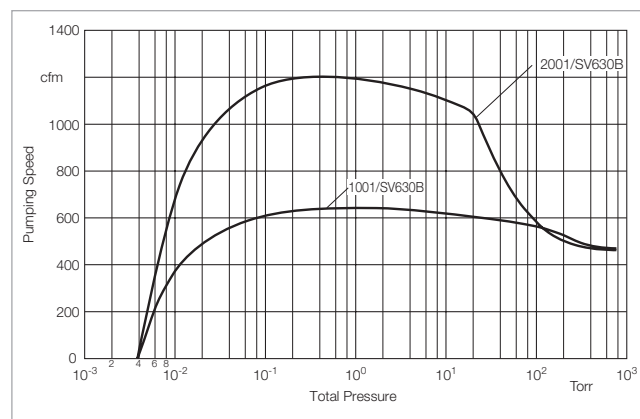

Pumping speed diagram for the HTS close-coupled systems with WSU series Roots blowers and SOGEVAC SV 630B at 60 Hz

Dimensions for SV 200 and SV 300 B only

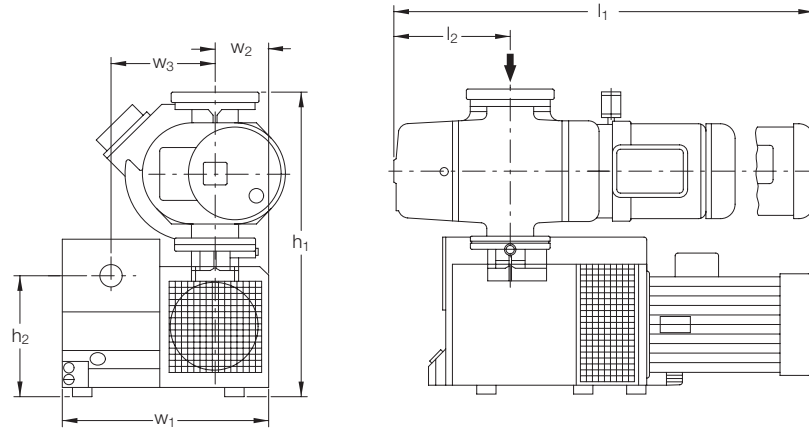

Dimensions for SV 630 B only

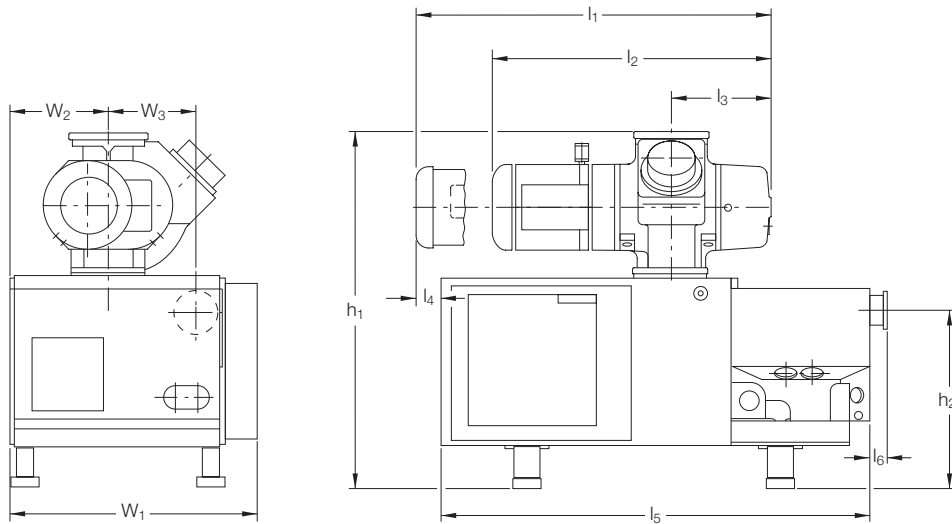

Roots Pump	Vane Pump	h_1	h_2	l_1	l_2	l_3	l_5	l_6	w_1	w_2	w_3
WSU 501	SV 200	29 7/16 (748)	12 17/32 (318)	-	9 17/32 (242)	-	-	-	21 11/16 (551)	6 1/8 (156)	10 19/32 (269)
WSU 501	SV 300 B	29 7/16 (748)	12 17/32 (318)	-	9 17/32 (242)	-	-	-	21 11/16 (551)	6 1/8 (156)	10 19/32 (269)
WSU 1001	SV 200	31 7/16 (799)	12 17/32 (318)	-	11 15/16 (303)	-	-	-	21 1/16 (535)	5 1/2 (140)	10 19/32 (269)
WSU 1001	SV 300 B	31 7/16 (799)	12 17/32 (318)	-	11 15/16 (303)	-	-	-	22 13/16 (579)	7 1/4 (184)	10 19/32 (269)
WSU 2001	SV 630 B	48 5/16 (1227)	23 13/16 (605)	50 3/16 (1275)	-	14 9/16 (370)	60 3/4 (1543)	2 1/2 (64)	34 15/16 (887)	13 7/8 (352)	12 13/32 (315)

Dimensional drawing for the HTS close-coupled system with single-stage SOGEVAC backing pumps; dimensions in brackets () are in mm

Technical Data

HTS Close-Coupled Systems

		501/SV200	501/SV300B	1001/SV200	1001/SV300B
RUVAC		WSU 501	WSU 501	WSU 1001	WSU 1001
SOGEVAC		SV 200	SV 300 B	SV 200	SV 300 B
Pumping speed @ 0.1 Torr	cfm (m ³ /h)	277 (470)	285 (483)	504 (855)	545 (925)
Ultimate total pressure	Torr (mbar)	< 8 x 10 ⁻³ (< 1 x 10 ⁻²)	< 8 x 10 ⁻³ (< 1 x 10 ⁻²)	< 8 x 10 ⁻³ (< 1 x 10 ⁻²)	< 8 x 10 ⁻³ (< 1 x 10 ⁻²)
Connecting flanges					
Inlet port WSU	DN	3" ANSI	3" ANSI	4" ANSI	4" ANSI
Exhaust port SOGEVAC	DN	2" NPT	2" NPT	2" NPT	2" NPT
Operating voltage	V	208/230/460	208/230/460	208/230/460	208/230/460
Phase / Frequency ¹⁾	- / Hz	3 / 60	3 / 60	3 / 60	3 / 60
Full load amps ²⁾					
RUVAC WSU		7.8/10.0/5.8	7.8/10.0/5.8	13.0/14.7/8.5	13.0/14.7/8.5
SOGEVAC		21.0/18.0/9.0	29.0/25.0/12.5	21.0/18.0/9.0	29.0/25.0/12.5
Displacement					
RUVAC	cfm (m ³ /h)	357 (606)	357 (606)	707 (1200)	707 (1200)
SOGEVAC	cfm (m ³ /h)	130 (606)	200 (340)	130 (606)	200 (340)
Oil capacity					
RUVAC WSU	qt (l)	1.10 (1.00)	1.10 (1.00)	2.10 (2.00)	2.10 (2.00)
SOGEVAC	qt (l)	5.30 (5.00)	9.00 (8.50)	5.30 (5.00)	9.00 (8.50)
Nominal rotation speed					
RUVAC WAU/WSU	rpm (min ⁻¹)	3600 (3600)	3600 (3600)	3600 (3600)	3600 (3600)
SOGEVAC	rpm (min ⁻¹)	1800 (1800)	1800 (1800)	1800 (1800)	1800 (1800)
Motor power					
RUVAC WSU	hp (kW)	3.3 (2.4)	3.3 (2.4)	6.0 (4.4)	6.0 (4.4)
SOGEVAC	hp (kW)	7.5 (5.5)	10.0 (7.4)	7.5 (5.5)	10.0 (7.4)

Ordering Information

HTS Close-Coupled Systems

		501/SV200	501/SV300B	1001/SV200	1001/SV300B
		Part. No.			
HTS - close-coupled systems		Ordering Information see right page			

¹⁾ For 50 Hz systems, consult the factory

²⁾ Determined by operating voltage

Technical Data

HTS Close-Coupled Systems

1001/SV630B

2001/SV630B

RUVAC		1001	2001
SOGEVAC		SV 630 B	SV 630 B
Pumping speed @ 0.1 Torr	cfm (m ³ /h)	610 (1035)	1186 (2031)
Ultimate total pressure	Torr (mbar)	< 8 x 10 ⁻³ (< 1 x 10 ⁻²)	< 8 x 10 ⁻³ (< 1 x 10 ⁻²)
Connecting flanges			
Inlet port WSU	DN	4" ANSI	6" ANSI
Outlet port	DN	4" ANSI	4" ANSI
Operating voltage	V	460	460
Phase / Frequency ¹⁾	- / Hz	3 / 60	3 / 60
Full load amps ²⁾			
RUVAC WSU		8.5	5.0
SOGEVAC		29.5	29.5
Displacement			
RUVAC	cfm (m ³ /h)	707 (1200)	1449 (2460)
SOGEVAC	cfm (m ³ /h)	495 (840)	495 (840)
Oil capacity			
RUVAC WSU	qt (l)	2.10 (2.0)	4.20 (4.0)
SOGEVAC	qt (l)	37.0 (35.0)	37.0 (35.0)
Nominal rotation speed			
RUVAC WSU	rpm (min ⁻¹)	3600 (3600)	3600 (3600)
SOGEVAC	rpm (min ⁻¹)	1170 (1170)	1170 (1170)
Motor power			
RUVAC WSU	hp (kW)	6.1 (4.5)	11.4 (8.4)
SOGEVAC	hp (kW)	25.0 (13.4)	25.0 (13.4)

Ordering Information

	Part No. 180036V-
Blower / TRIVAC pump	
WSU 501 / SV 200	52
WSU 501 / SV 300 B	53
WSU 1001 / SV 200	12
WSU 1001 / SV 300 B	13
WSU 1001 / SV 630 B	16
WSU 2001 / SV 630 B	26
Casters & Levelers (SV 200 & SV 300 only)	
None	0
Casters & Levelers	1
Casters only	2
Levelers only	3
Electrical Control Panel	
None	0
208 V (SV 200 & SV 300 only)	1
230 V (SV 200 & SV 300 only)	2
460 V	3

Central Vacuum Supply Systems with SOGEVAC Pumps



Central vacuum supply systems: CVS500 with 3 SOGEVAC SV 100 B, CVS 160 with 2 SOGEVAC SV 100 B, CVS 60 with 1 SOGEVAC SV 40 B

Central vacuum supply systems are frequently used in those cases where a large number of minor requirements for vacuum need to be economically covered. Moreover, the systems serve the purpose of compensating for large variations in the number of vacuum consumers and increase the availability of the vacuum service.

A typical central vacuum supply system from Leybold consists chiefly of one or more SOGEVAC rotary vane vacuum pumps, a buffer vessel, an electrical cabinet with controller as well as the corresponding connection components. The systems are supplied by us fully assembled, tested as plug and play units.

Standard Equipment

Typically consisting of

- up to 3 SOGEVAC pumps
- buffer vessel
- manual valve (basic control) or electropneumatic valve (PLC control)
- dust filter at the pump inlet
- pressure sensor
- two-stage pressure controller
- electrical cabinet with controller
- all connecting components

Advantages to the User

- Industrial grade vacuum generator consisting of proven SOGEVAC single-stage rotary vane vacuum pumps
- Covers the demands of numerous small vacuum consumers
- Modular design, customized to customer specific processes
- Simple to operate
- Space-saving system solution
- High return on investment, excellent price-to-performance ratio
- Energy saving capabilities
- Low cost of ownership
- Cycle time reduction due to the buffer volume
- Complete turn-key systems, ready for operation

Typical Applications

General applications demanding vacuum:

- Transportation
- Handling / lifting
- Degassing
- Automation (pick and place)

Automotive industry

- Thermoforming
- Break filling, degassing

Composites manufacturing

- Resin Transfer Moulding (RTM)

Vacuum pressing, like rubber, plastics, gaskets

Food packaging/food processing

- Vacuum filling
- Thermoforming
- Vacuum transportation, handling, lifting
- Tray sealing / MAP packaging
- Degassing

Hospitals/Medical engineering

- Bacteriological filters

Controller Types for the Central Vacuum Supply Systems from Leybold

Generally a difference is made between the controller types **BASIC** and **FF** (Full Featured).

Differing custom solutions are available upon request.

BASIC Controller

The Basic controller provides for two freely selectable switching thresholds, through which an individual vacuum pump or alternatively a blocking valve (optional) can be driven.

Moreover, the controller includes an electronic pressure display and an operating hours counter.

This type of controller is suited for systems equipped with a single pump up to a nominal pumping speed of 100 m³/h (58.9 cfm).

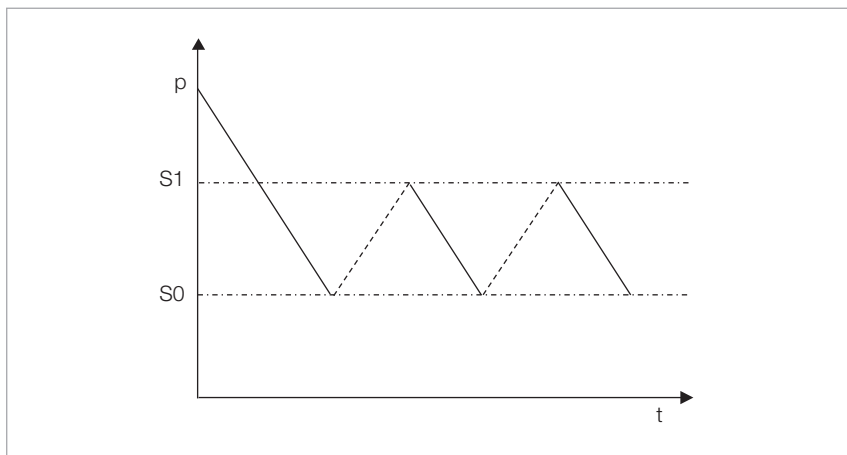

Basic control with one pump

Operating Principle of the BASIC Controller

Starting at atmospheric pressure, the central vacuum supply system is evacuated down to the intended “lower operating pressure” S0. As soon as the pressure has attained the level of S0, the vacuum pump is switched off automatically, respectively the optional blocking valve is closed.

When switching on the consumers, the pressure in the system rises again until the “upper operating pressure” is reached thereby tripping the switch-on threshold S1 of the pump, respectively attaining the opening pressure of the valve.

Provided pumping speed of the pump and vacuum consumption are balanced, the operating pressure will change between S0 and S1. At reduced consumption, the system pressure will reduce until the switching threshold S0 is reached again causing the pump to switch off, respectively the valve to close etc.

FF Controller

Basically the FF controller provides for four freely selectable switching thresholds and has thus been designed to operate two pumps running in parallel. Depending on the design rating and current demand, the base load or master pump will operate alone or jointly together with the spare pump.

In order to spread the number of operating hours equally between the pumps, master pump and spare pump are interchanged in regular intervals. In case a pump fails, the controller effects an automatic change to the spare pump.

For operating vacuum pumps having a nominal pumping speed of over

100 m³/h (58.9 cfm), a delayed shut-down facility has been integrated which will restrict the number of switching cycles to 6 per hour.

Through the use of a Programmable Logic Controller (PLC), the FF controller permits flexible coverage of quite differing requirements.

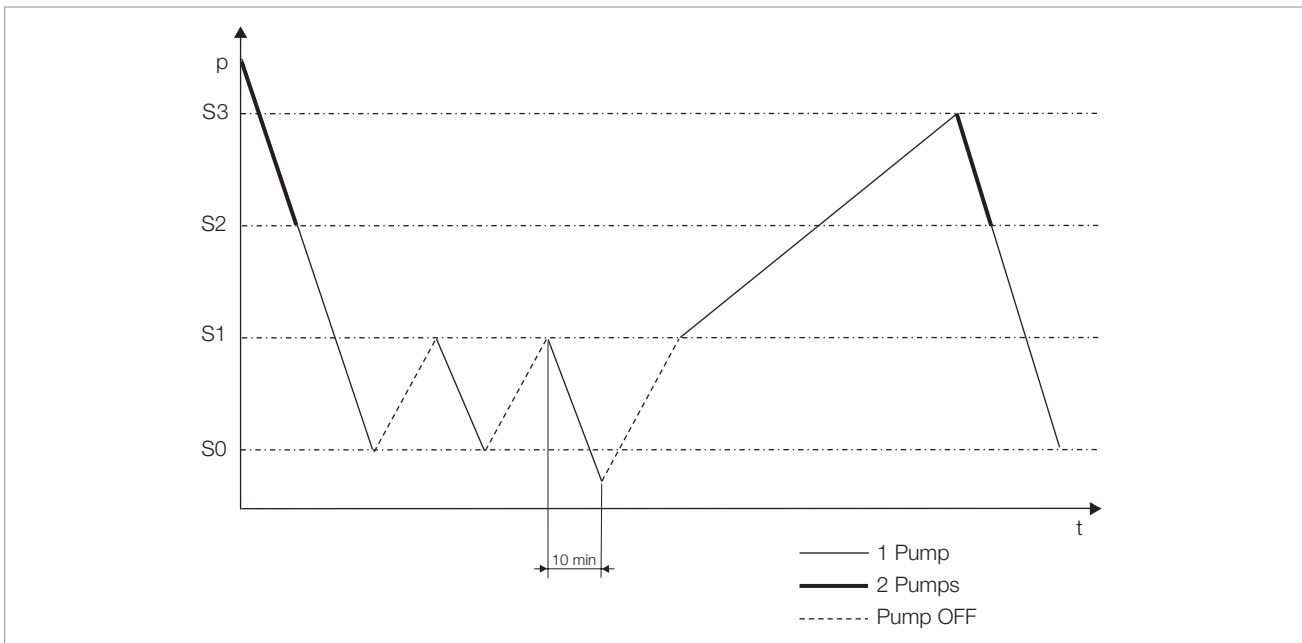

FF controller with two pumps and an example for delayed shutdown (pumps over 100 m³/h (58.9 cfm))

Operating Principle of the FF Controller

Just as for the Basic controller, the system is, upon switching on, evacuated down to the lower operating pressure S0. This is effected with both pumps running in parallel (master pump and spare pump) until the shutdown threshold for the spare pump S2 is reached. Thereafter, the master pump alone will ensure that the lower operating pressure is reached and is then also switched off. When the system pressure increases due to the number of consumers or leaks to the level of S1, then the master pump will be switched on automatically etc.

In the case of vacuum pumps having a pumping speed of over 100 m³/h (58.9 cfm) and a running time of the pump of less than 10 minutes, then the standard switch off delay can be responsible for the pressure to drop below S0. This will prevent too frequent switching on and off of the pumps.

If for process reasons the pressure is not allowed to drop below the lower operating pressure, we recommend

the use of electropneumatic or solenoid blocking valves.

If the current vacuum demand cannot be met by the master pump alone, the system pressure will increase to the upper switching pressure S3 upon which the spare pump is automatically started.

With both pumps running in parallel, the system is then again evacuated until the switch off threshold S2 for the spare pump is reached again etc.

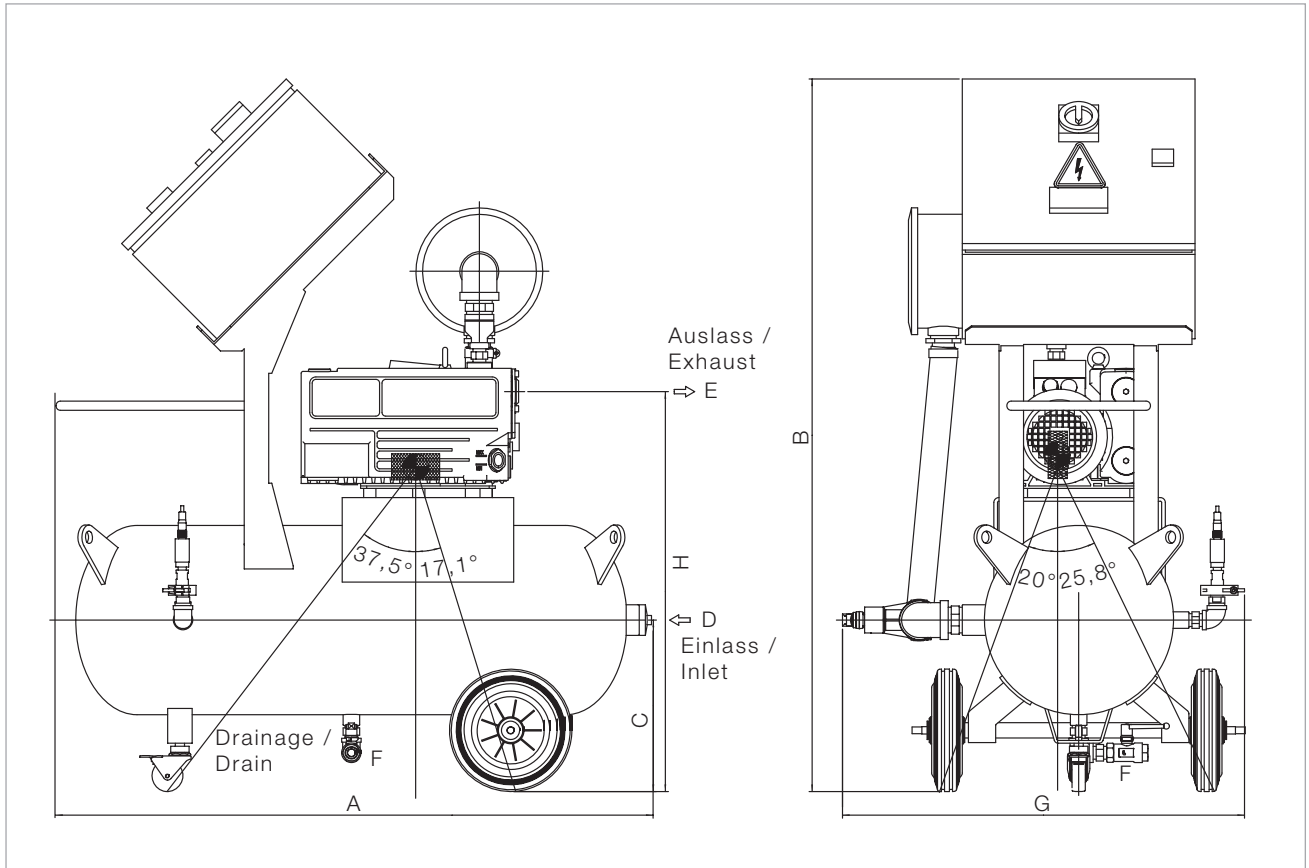

Dimensional drawing CVS60 with SV25B

CVS-System *	A	B	C	D	E	F	G	H
CVS60 1xSV25B	973	1163	280	G 1¼"	G ¾"	G ½"	656	653
CVS60 1xSV40B	973	1163	280	G 1¼"	G 1¼"	G ½"	656	697

* Dimensions in mm

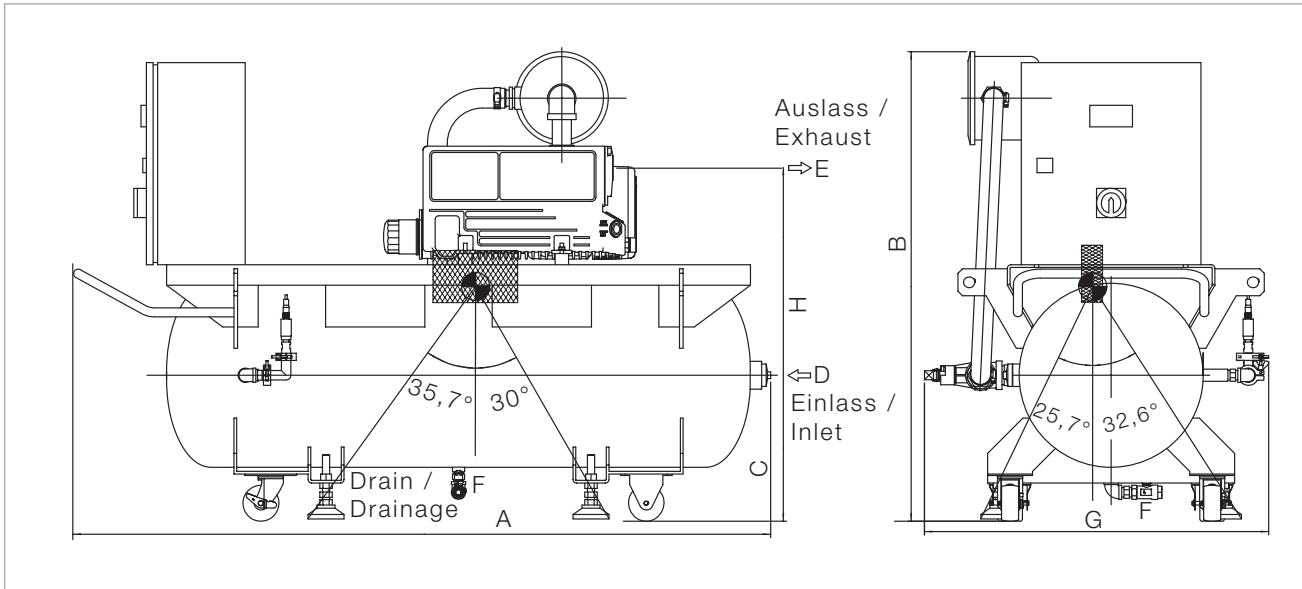

Dimensional drawing CVS160 with SV65B

CVS-System *	A	B	C	D	E	F	G	H
CVS160 1xSV65B	1542	1045	325	G 1¼"	G 1¼"	G ½"	766	787
CVS300 1XSV65B	1819	1155	385	G2"	G 1¼"	G ½"	826	897
CVS160 1XSV100B	1542	1050	325	G 1¼"	G 1¼"	G ½"	766	791
CVS300 1XSV100B	1819	1160	385	G2"	G 1¼"	G ½"	826	901
CVS500 1XSV100B	1976	1310	485	G2"	G 1¼"	G 1¼"	927	1051
CVS500 1XSV200	1976	1509	485	G2"	G2"	G 1¼"	927	1149
CVS1000 1XSV200	2395	1719	585	G2"	G2"	G 1¼"	1136	1359
CVS500 1XSV300B	1976	1514	485	G2"	G2"	G 1¼"	927	1161
CVS1000 1XSV300B	2395	1724	585	G2"	G2"	G 1¼"	1136	1371

* Dimensions in mm

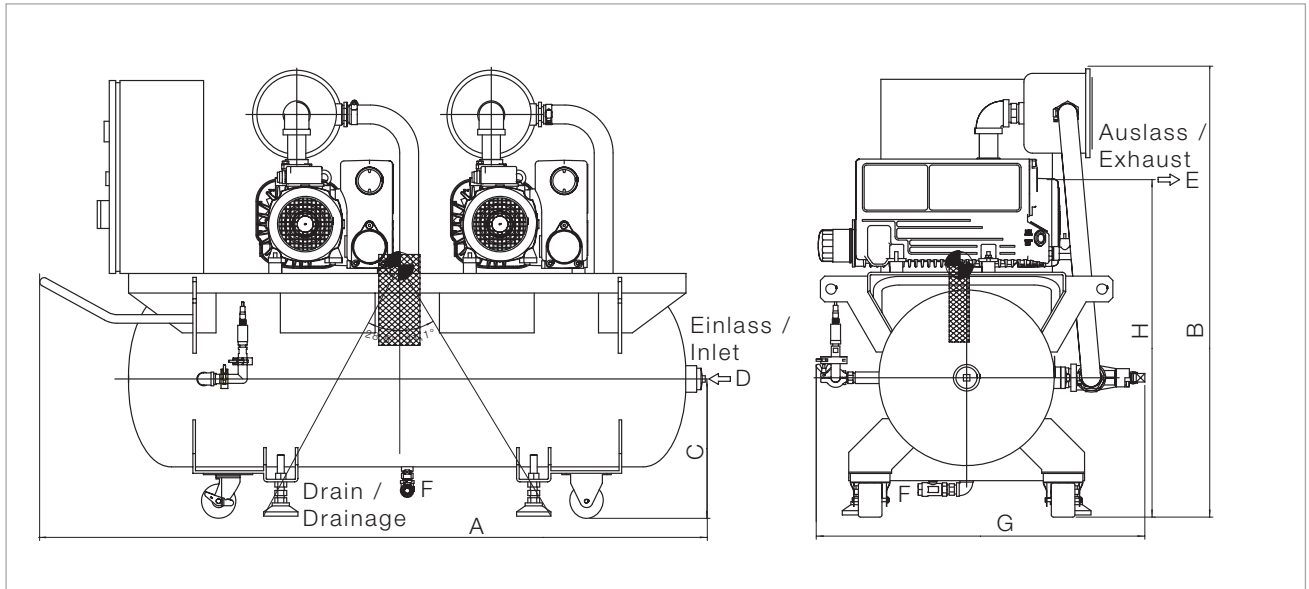

Dimensional drawing CVS160 with 2x SV65B

CVS-System *	A	B	C	D	E	F	G	H
CVS500 2xSV100B	1976	1310	485	G 2"	G 1¼"	G 1¼"	940	1051
CVS500 2xSV200	1976	1509	485	G 2"	G2"	G 1¼"	1107	1149
CVS1000 2xSV200	2395	1719	585	G 2"	G2"	G 1¼"	1223	1359
CVS500 2xSV300B	1976	1514	485	G 2"	G2"	G 1¼"	1107	1161
CVS1000 2xSV300B	2395	1724	585	G 2"	G2"	G 1¼"	1189	1371

* Dimensions in mm

Technical Data and Ordering Information

CVS BASIC Systems

Part No.	Designation	Nominal pumping speed* m ³ /h	Weight, approx. kg	Connection	Noise level** dB(A)	Motor power	Nominal current max. A	Power connection
				Inlet / Exhaust G or NPT		kW		
504309V001	CVS60 – 1 x SV25B	26	145	1¼" / ¾"	64	0,9 1,1	2,3 2,6	400 V / 50 Hz 460 V / 60 Hz
504309V002	CVS60 – 1 x SV40B	44	165	1¼" / 1¼"	58	1,1 1,5	2,8 2,7	400 V / 50 Hz 460 V / 60 Hz
504310V001	CVS160 – 1 x SV65B	59	255	1¼" / 1¼"	60	1,5 1,8	3,8 3,7	400 V / 50 Hz 460 V / 60 Hz
504310V004	CVS160 – 1 x SV100B	97,5	295	1¼" / 1¼"	61	2,2 3,5	4,5 5,3	400 V / 50 Hz 460 V / 60 Hz
504311V001	CVS300 – 1 x SV65B	59	340	2" / 1¼"	60	1,5 1,8	3,8 3,7	400 V / 50 Hz 460 V / 60 Hz
504311V004	CVS300 – 1 x SV100B	97,5	335	2" / 1¼"	61	2,2 3,5	4,5 5,3	400 V / 50 Hz 460 V / 60 Hz
504312V006	CVS500 – 1 x SV100B	97,5	415	2" / 1¼"	61	2,2 3,5	4,5 5,3	400 V / 50 Hz 460 V / 60 Hz
504312V007	CVS500 – 2 x SV100B	195	550	2" / 1¼"	64	4,4 7,0	9,0 10,6	400 V / 50 Hz 460 V / 60 Hz
504312V011	CVS500 – 1 x SV200	180	460	2" / 2"	69	4,0 4,6	8,9 10,0	400 V / 50 Hz 460 V / 60 Hz
504312V012	CVS500 – 2 x SV200	360	630	2" / 2"	72	8,0 9,2	17,8 20,0	400 V / 50 Hz 460 V / 60 Hz
504312V014	CVS500 – 1 x SV300B	280	500	2" / 2"	72	5,5 6,3	10,5 9,3	400 V / 50 Hz 460 V / 60 Hz
504312V015	CVS500 – 2 x SV300B	560	725	2" / 2"	75	11,0 12,6	21,0 18,6	400 V / 50 Hz 460 V / 60 Hz
504313V011	CVS1000 – 1 x SV200	180	600	2" / 2"	69	4,0 4,6	8,9 10,0	400 V / 50 Hz 460 V / 60 Hz
504313V012	CVS1000 – 2 x SV200	360	775	2" / 2"	72	8,0 9,2	17,8 20,0	400 V / 50 Hz 460 V / 60 Hz
504313V016	CVS1000 – 1 x SV300B	280	640	2" / 2"	72	5,5 6,3	10,5 9,3	400 V / 50 Hz 460 V / 60 Hz
504313V017	CVS1000 – 2 x SV300B	560	860	2" / 2"	75	11,0 12,6	21,0 18,6	400 V / 50 Hz 460 V / 60 Hz

* 50 Hz

** At ultimate pressure without gas ballast, free-field measurement, distance 1 m

Beyond the equipment which is supplied as standard, the modular design of the central vacuum supply systems from Leybold allows for customization according to your specific requirements.

Optionally available are, for example:

- Higher pumping speeds and larger buffer volumes
- Electropneumatic or solenoid blocking valves
- Mobile construction on castors
- Other mains voltages
- Additional pumps, filters, fittings etc.

Technical Data and Ordering Information

CVS FF Systems

Part No.	Designation	Nominal pumping speed* m ³ /h	Weight, approx. kg	Connection	Noise level** dB(A)	Motor power	Nominal current max. A	Power connection
				Inlet / Exhaust G or NPT		kW		
504310V050	CVS160 – 2 x SV65B	118	350	1¼" / 1¼"	63	3,0 3,6	7,6 7,4	400 V / 50 Hz 460 V / 60 Hz
504310V051	CVS160 – 2 x SV100B	195	430	1¼" / 1¼"	64	4,4 7,0	9,0 10,6	400 V / 50 Hz 460 V / 60 Hz
504311V050	CVS300 – 2 x SV65B	118	410	2" / 1¼"	63	3,0 3,6	7,6 7,4	400 V / 50 Hz 460 V / 60 Hz
504311V051	CVS300 – 2 x SV100B	195	470	2" / 1¼"	64	4,4 7,0	9,0 10,6	400 V / 50 Hz 460 V / 60 Hz
504312V050	CVS500 – 3 x SV65B	177	560	2" / 1¼"	65	4,5 5,4	11,4 11,1	400 V / 50 Hz 460 V / 60 Hz
504312V051	CVS500 – 2 x SV100B	195	550	2" / 1¼"	64	4,4 7,0	9,0 10,6	400 V / 50 Hz 460 V / 60 Hz
504312V052	CVS500 – 3 x SV100B	292,5	680	2" / 1¼"	66	6,6 10,5	13,5 15,9	400 V / 50 Hz 460 V / 60 Hz
504312V053	CVS500 – 2 x SV200	360	630	2" / 2"	72	8,0 9,2	17,8 20,0	400 V / 50 Hz 460 V / 60 Hz
504312V054	CVS500 – 2 x SV300B	560	725	2" / 2"	75	11,0 12,6	21,0 18,6	400 V / 50 Hz 460 V / 60 Hz
504313V050	CVS1000 – 3 x SV65B	177	700	2" / 1¼"	65	4,5 5,4	11,4 11,1	400 V / 50 Hz 460 V / 60 Hz
504313V051	CVS1000 – 2 x SV300B	195	690	2" / 1¼"	64	4,4 7,0	9,0 10,6	400 V / 50 Hz 460 V / 60 Hz
504313V052	CVS1000 – 3 x SV100B	292,5	820	2" / 1¼"	66	6,6 10,5	13,5 15,9	400 V / 50 Hz 460 V / 60 Hz
504313V053	CVS1000 – 2 x SV200	360	775	2" / 2"	72	8,0 9,2	17,8 120,0	400 V / 50 Hz 460 V / 60 Hz
504313V054	CVS1000 – 3 x SV200	540	950	2" / 2"	74	12,0 13,8	26,7 230,0	400 V / 50 Hz 460 V / 60 Hz
504313V055	CVS1000 – 2 x SV300B	560	860	2" / 2"	75	11,0 12,6	21,0 18,6	400 V / 50 Hz 460 V / 60 Hz
504313V056	CVS1000 – 3 x SV300B	840	1080	2" / 2"	77	16,5 18,9	31,5 27,9	400 V / 50 Hz 460 V / 60 Hz

* 50 Hz

** At ultimate pressure without gas ballast, free-field measurement, distance 1 m

Beyond the equipment which is supplied as standard, the modular design of the central vacuum supply systems from Leybold allows for customization according to your specific requirements.

Optionally available are, for example:

- Higher pumping speeds and larger buffer volumes
- Electropneumatic or solenoid blocking valves
- Mobile construction on castors
- Other mains voltages
- Additional pumps, filters, fittings etc.

Only available for purchase in North and South America

Central Vacuum Supply Systems

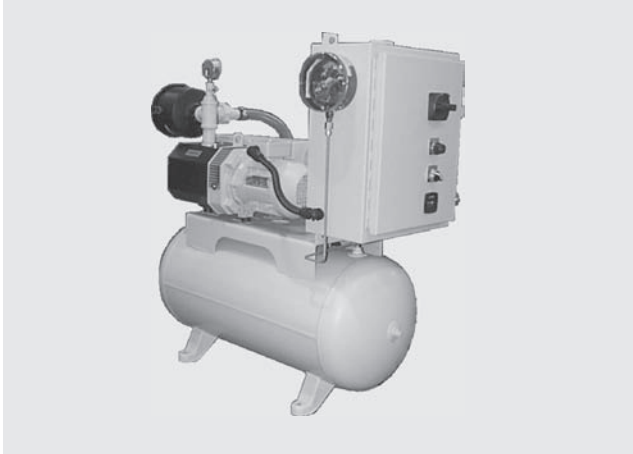

Central vacuum supply system, simplex

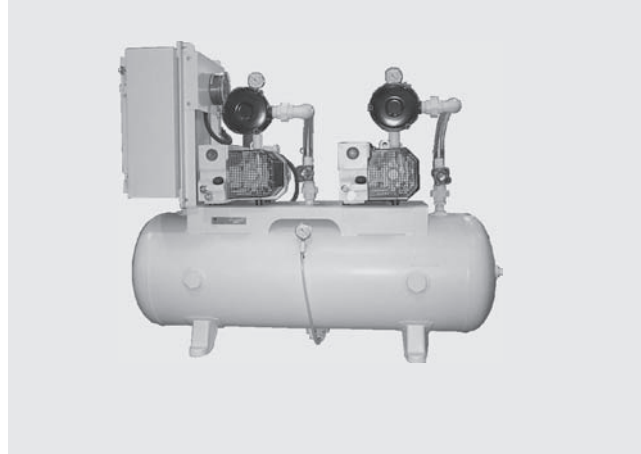

Central vacuum supply system, duplex

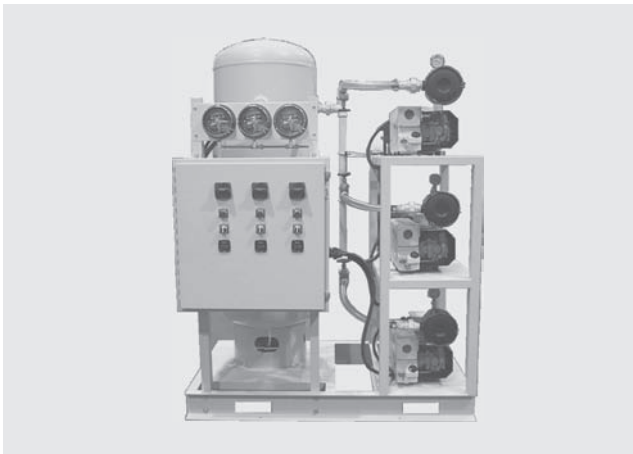

Central vacuum system, triplex

Standard Equipment

- ASME® rated receiver tank
- Flexible configurations for one, two, or three SOGEVAC pumps
- Manual isolation valves
- Simple operation, high reliability, easy maintenance
- Complete package with gauges and NEMA12 controls
- Standard "ON/OFF/AUTO" switch
- Elapsed time meters
- Inlet particulate filters
- Lead/Lag or continuous operation of pumps
- Adjustable pressure switch for control of vacuum level
- Air-cooled SOGEVAC pumps with built-in "anti-suckback" valves

Options

- Tank or stack mounted pumps
- Larger receiver tank
- Special inlet filters
- Automatic isolation valves
- Special design controls per customer specification

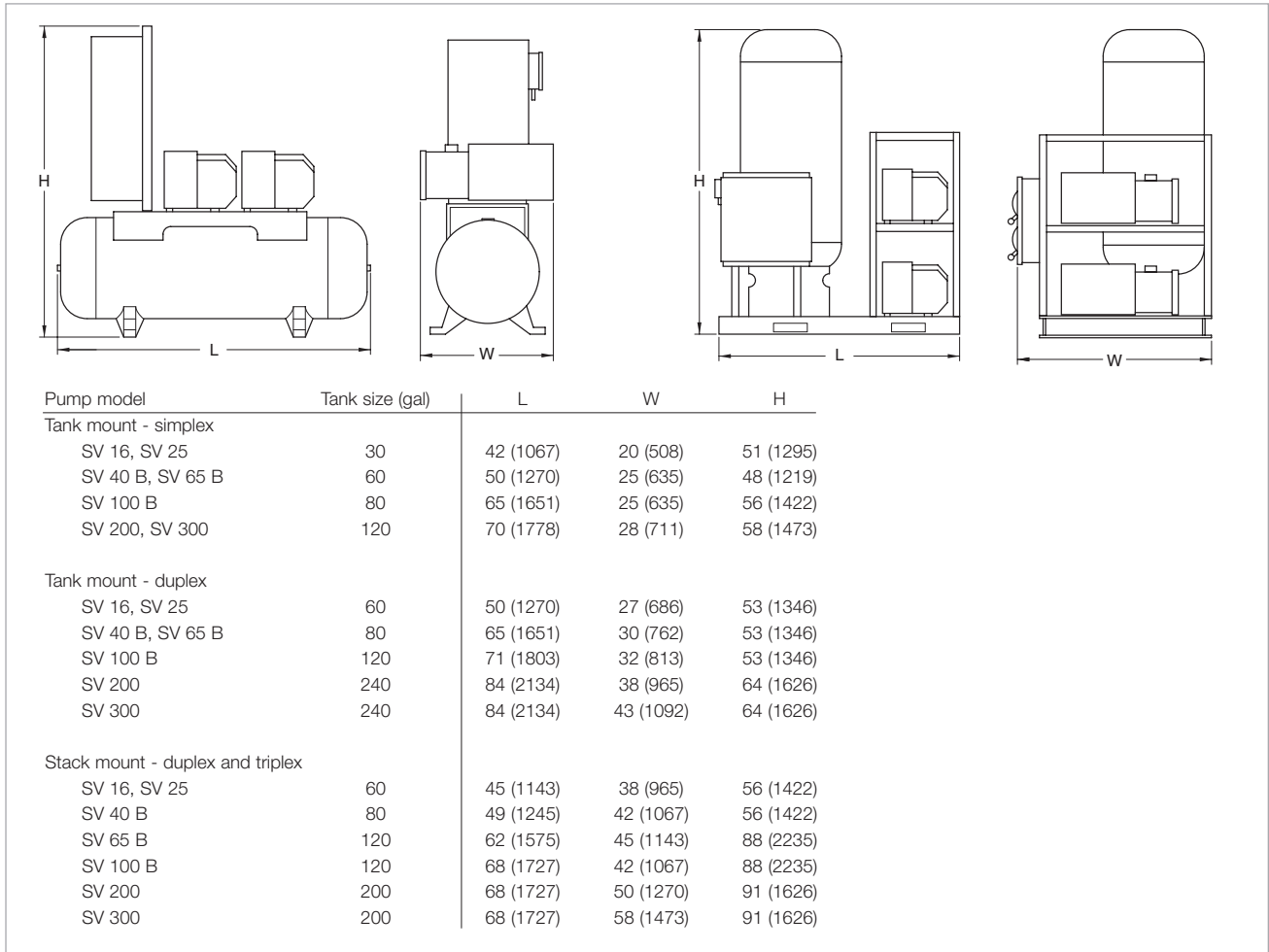

Central vacuum supply systems, tank mounted [left] and stack mounted [right]; dimensions in inch, dimensions in brackets () are in mm

Technical Data

Performance Characteristics

		SV 16	SV 25	SV 40 B	SV 65 B	SV 100 B	SV 200	SV 300
Free air displacement	cfm (m ³ /h)	11 (18.6)	17.0 (29.0)	31.2 (53.0)	41.8 (71.0)	68.9 (117.0)	129.5 (219.8)	200.3 (340.0)
Actual pumping speed	cfm (m ³ /h)	10 (16.9)	15 (25.5)	27.7 (47.0)	37.7 (64.0)	61.8 (105.0)	117.8 (200.0)	170.8 (289.9)
Guaranteed base pressure	Torr	0.4	0.4	0.4	0.4	0.4	0.06	0.06
Base pressure with gas ballast	Torr	1.1	1.1	1.1	1.1	1.0	0.5	0.5
Water vapor tolerance	Torr	30.0	30.0	22.5	22.5	22.5	30.0	30.0
Water vapor pumping with gas ballast	qt/hr	0.32	0.48	0.95	1.32	1.8	5.7	7.8
Noise level at 3 feet with 1 pump running without gas ballast	dB(A)	56	56	63	64	64	73	74
Motor	hp	1.0	1.5	2.0	2.5	4.0	7.5	10.0
Pump rotational speed	rpm	1750	1500	1750	1750	1750	1750	1750
Oil capacity	qt	2.0	2.0	1.05	2.1	2.1	5.5	9.0
Inlet / exhaust – NPT	in.	1/2 / 1/2	1/2 / 1/2	1-1/4 / 1-1/4	1-1/4 / 1-1/4	1-1/4 / 1-1/4	2 / 2	2 / 2
Pump weight	lbs	50.7	52.9	99.3	114.8	194.3	341.8	430.0

Technical Data

Tank Mount Simplex

Tank Mount Duplex

Stack Mount Duplex and Simplex

System	Tank size (gal)	Simplex	Duplex	Duplex and Simplex
SV 16, SV 25	Tank size (gal)	30	60	60
SV 40 B	Tank size (gal)	60	80	80
SV 65 B	Tank size (gal)	60	120	120
SV 100 B	Tank size (gal)	80	120	120
SV 200	Tank size (gal)	120	240	200
SV 300	Tank size (gal)	120	240	200

Ordering Information

System

- Simplex
- Duplex
- Triplex

Pumps

- SV 16 (1 hp)
- SV 25 (1.5 hp)
- SV 40 B (2.5 hp)
- SV 65 B (3 hp)
- SV 100 B (4 hp)
- SV 200 (7.5 hp)
- SV 300 (10 hp)

Mounting

- Tank mount
- Stack mount

Voltage

- 460/3/60
- 230/3/60
- 230/1/60 (available for SV 16/SV 25 only)
- 208/3/60 (available for SV 25 only)
- 115/1/60 (available for SV 16 only)

Duty

- Continuous
- Demand Start/Stop

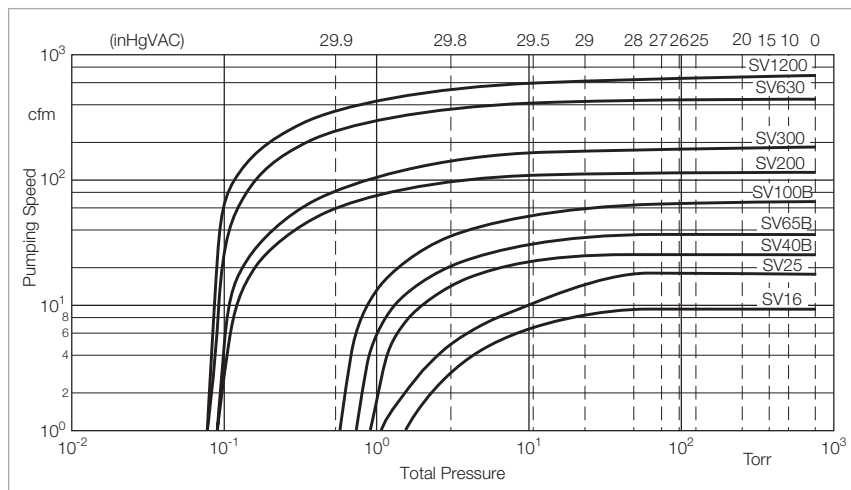
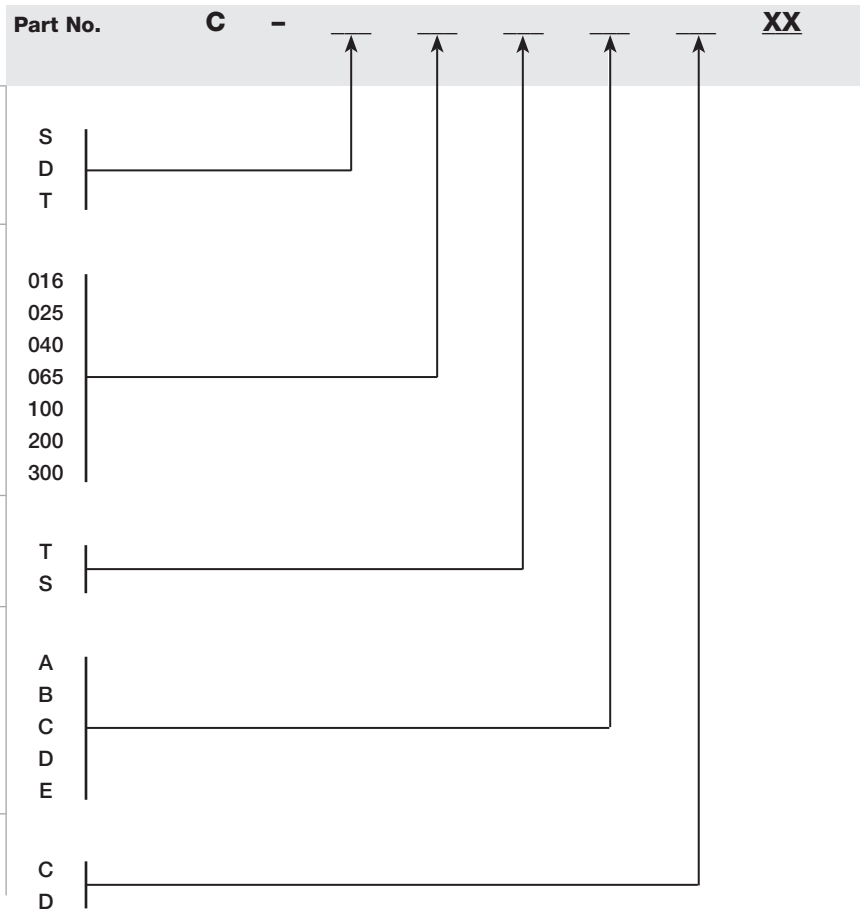

Pumping speed characteristics for the central vacuum supply systems at 60 Hz

Only available for purchase in North and South America

Tank Mounted Medical Vacuum Systems

**NFPA 99C compliant and designed for use in medical applications –
hospitals, out-patient surgical and other medical facilities**



Tank mounted medical vacuum system

Leybold tank mounted systems are completely assembled with interconnecting piping, are factory tested and leak-checked prior to shipment. Some items may be disassembled for protection during shipment. Required mechanical re-assembly requirements will be clearly noted, as well as needed electrical connections, and are the responsibility of the installer.

System Features

Key features for these duplex systems include two SOGEVAC series oil sealed rotary vane vacuum pumps with displacements up to 69 cfm each, an ultimate vacuum of better than 29.95" Hg, and automatic oil recirculation system with integral coalescing exhaust demisters as standard. ASME rated receiver tanks, NEMA12 / UL listed electrical enclosure and inter-connecting hardware. Each turn-key system is fully assembled and tested at Leybold Vacuum's factory and includes an operation manual and 12 month warranty.

Other System Features

Vacuum pumps and systems:

- Direct-coupled TEFC, IP 55 rated motors
- Integral gas ballast
- Anti suck back valve
- Air-cooled design
- NPT type inlet and exhaust connections
- Inlet protection
 - particulate filters rated for 10 micron retention
 - Isolation ball valves
 - Pump check valves
- Vacuum gauge, 0 – 30" Hg
- Vertical receiver, ASME coded, manual drain valve and tank bypass

Local duplex motor control center:

- 2x magnetic motor starters with overload protection
- Main fused disconnect switch
- 2x through the door disconnect switches
- 2x individual control transformers
- 2x elapsed time meters
- 2x hand-off-auto switches
- Lag pump audible alarm with indicator light
- Automatic alternation
 - Lead / Lag operation
- 2x dual set-point vacuum switches
- Emergency stop
- NEMA12, UL listed enclosure
- System wired for either 208/230/460 V, 3 phase, 60 Hz operation

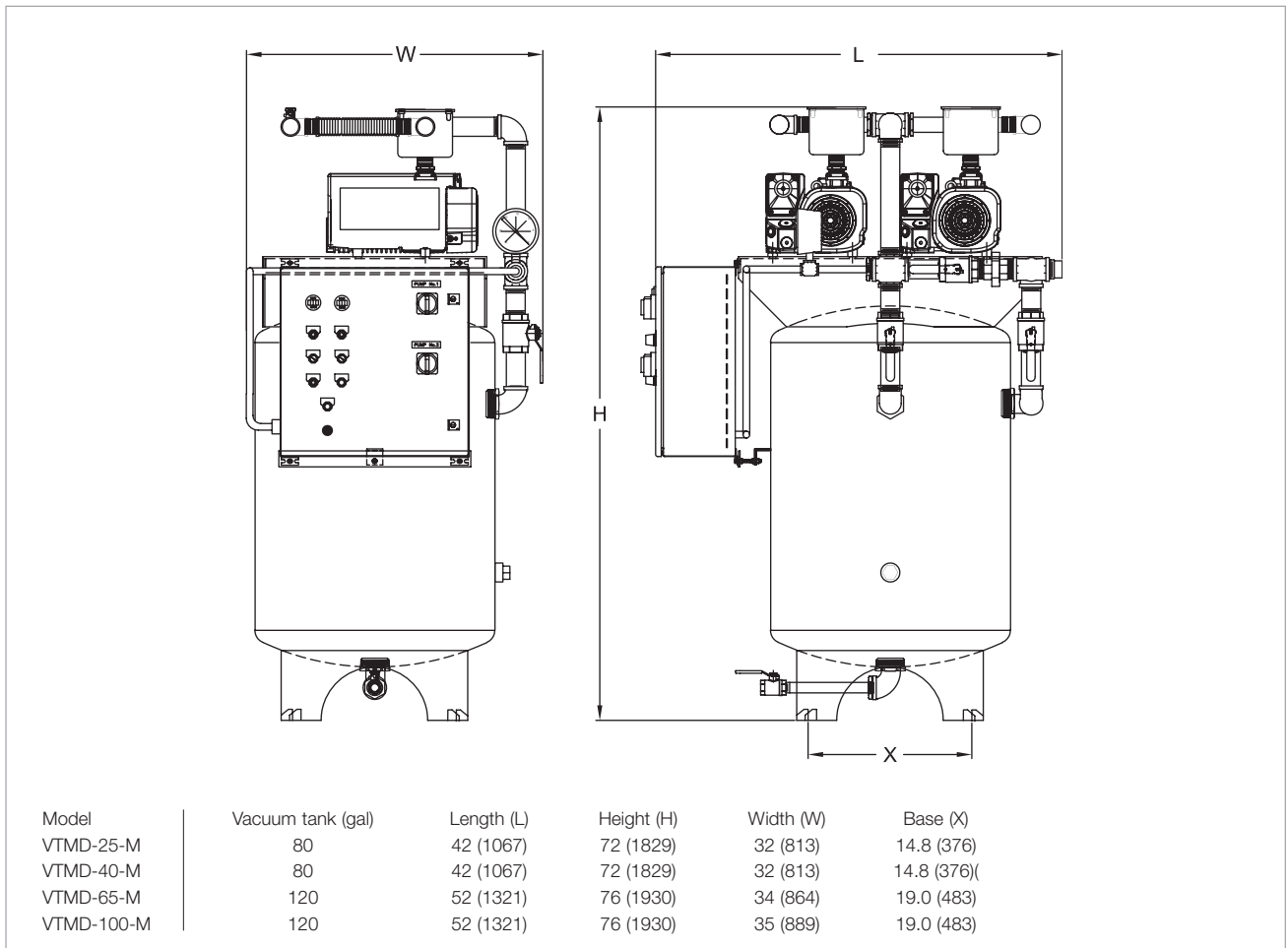

Tank mounted medical vacuum systems; dimensions in inch, dimensions in brackets () are in mm

Technical Data

VTMD-25-M VTMD-40-M VTMD-65-M VTMD-100-M

Displacement (per pump)	cfm	18.3	31.2	41.8	69.0
Capacity 19" HG (VAC) (per pump)	scfm	6.7	11.4	15.3	25.1
Motor (per pump)	hp (W)	1.5 (2.0)	2.0 (2.7)	3.0 (4.1)	5.0 (6.8)
Vacuum tank	gal	80	80	120	120
Vacuum inlet	NPT	1.5"	1.5"	1.5"	1.5"
Vacuum outlet ¹⁾	NPT	1.25"	1.25"	1.25"	1.25"
Weight	lbs (kg)	700 (305)	750 (340)	1125 (510)	1300 (589)

Ordering Information

VTMD-25-M VTMD-40-M VTMD-65-M VTMD-100-M

	Part. No.	Part. No.	Part. No.	Part. No.
Tank mounted medical vacuum system				
208 V, 3 phase, 60 Hz	S 170 530	S 170 533	S 170 499	S 170 490
230 V, 3 phase, 60 Hz	S 170 531	S 170 534	S 170 536	S 170 538
460 V, 3 phase, 60 Hz	S 170 532	S 170 535	S 170 537	S 170 539

¹⁾ System consists of two outlet flanges

Dry Compressing Vacuum Pump System RUTA with SCREWLINE Backing Pump, Adaptor Version, without palette



RUTA WAU2001/SP630/A

Standard Equipment

- RUVAC WAU with air cooling
- RUVAC WH with water cooling
- Silencer
- SP-GUARD
- Manually operated gas ballast
- Gear oil collecting pan integrated within the screw pump
- Gear oil supplied with the pump
- Screw pump SCREWLINE SP 630 F with water cooling
- Screw pump SCREWLINE SP 250 with air cooling
- RUVAC WH including external frequency converter (frequency converter permits pumping speed control)
- CE approval
- Condensate drain valve at the silencer
- Sound proofing box
- Vibration absorbers
- Castors
- Different types of floor mounts
- Oil drain valve on each pump
- Electric control systems
- Non-return valve
- Screw pump SCREWLINE SP 630 with air cooling

Options

- Frequency converter for controlling the speed of the Roots pump (only RUVAC WA/WS)

Type	RUTA	501/SP250/A	1001/SP250/A	2001/SP630F/A	700/SP250/A
RUVAC WA/WAU/WS/WSU	P2	501	1001	2001	-
RUVAC WH	P2	-	-	-	700
Backing pump SCREWLINE	P1	SP 250	SP 250	SP 630 F	SP 250
	DN ₁	63 ISO-K	100 ISO-K	160 ISO-K	100 ISO-K
	DN ₂	63 ISO-K	63 ISO-K	100 ISO-K	63 ISO-K
	l	1350 (53.15)	1409 (55.47)	1804 (71.02)	1350 (53.15)
	l ₁	239 (9.41)	298 (11.73)	367 (14.45)	258 (10.16)
	l ₂	533 (20.98)	592 (23.31)	882 (34.72)	552 (21.73)
	l ₃	160 (6.30)	219 (8.62)	336 (13.23)	179 (7.05)
	l ₄	880 (34.65)	880 (34.65)	880 (34.65)	880 (34.65)
	b	761 (29.96)	828 (32.60)	1059 (41.69)	648 (25.51)
	b ₁	260 (10.24)	306 (12.05)	403 (15.87)	260 (10.24)
	b ₂	438 (17.24)	438 (17.24)	546 (21.50)	438 (17.24)
	b ₄	783 (30.83)	783 (30.83)	783 (30.83)	783 (30.83)
	b ₅	470 (18.50)	470 (18.50)	470 (18.50)	470 (18.50)
	h	1213 (47.76)	1239 (48.78)	1342 (52.84)	1158 (45.59)
	h ₁	954 (37.56)	954 (37.56)	1221 (48.07)	949 (37.36)

Dimensional drawing of the pump systems with dry compressing SCREWLINE SP backing pump, adaptor version, without palette. Left with WAU pumps, right with WH pump. Dimensions in brackets () are in inch

Technical Data, 50 Hz

RUTA

		WAU 501/SP250/A	WAU 1001/SP250/A	WAU 2001/SP630(F)/A	WH 700/SP250/A
RUVAC (WA/WAU/WS/WSU possible)	P2	501	1001	2001	–
RUVAC WH	P2	–	–	–	700
Backing pump SCREWLINE	P1	SP 250	SP 250	SP 630 (F)	SP 250
Pumping speed, 50 Hz at 10^{-1} mbar (7.5×10^{-2} Torr)	m ³ /h (cfm)	445.0 (262.1)	830.0 (488.9)	1745.0 (1027.8)	635 (374)
Ultimate total pressure without gas ballast	mbar (Torr)	$< 1 \times 10^{-3}$ ($< 7.5 \times 10^{-4}$)	$< 1 \times 10^{-3}$ ($< 7.5 \times 10^{-4}$)	$< 1 \times 10^{-3}$ ($< 7.5 \times 10^{-4}$)	$< 1 \times 10^{-3}$ ($< 7.5 \times 10^{-4}$)
Installed motor power 400 V, 50 Hz	kW (hp)	9.7 (13.0)	11.5 (15.6)	22.5 (30.6)	9.7 (13.0)
Electrical power consumption at 10^{-1} mbar (7.5×10^{-2} Torr)	kW (hp)	6.3 (8.6)	6.7 (9.1)	12.0 (16.3)	6.6 (8.9)
Noise level with silencer at 10^{-1} mbar (7.5×10^{-2} Torr)	dB(A)	75	77	79	75
Total weight with palette, approx.	kg (lbs)	720 (1187)	850 (1876)	1100 (2428)	720 (1587)
Connecting flange					
Inlet port	DN ₁	63 ISO-K	100 ISO-K	160 ISO-K	100 ISO-K
Outlet port	DN ₂	63 ISO-K	63 ISO-K	100 ISO-K	63 ISO-K

Ordering Information

RUTA

		WAU 501/SP250/A	WAU 1001/SP250/A	WAU 2001/SP630(F)/A	WH 700/SP250/A
	Part No.				
RUVAC (WA/WAU/WS/WSU possible)	P2	WAU 501	WAU 1001	WAU 2001	–
RUVAC WH	P2		–	–	WH 700
Backing pump SCREWLINE	P1	SP 250	SP 250	SP 630 (F)	SP 250
Pump system, complete (adaptor version), Without pallet with water-cooled SCREWLINE		502 465 V001	502 467 V001	502 471 V001	503 153 V001 ¹⁾
Frequency converter RUVATRONIC (see description in Chapter “Accessories”)		RT 5/501 500 001 382	RT 5/1001 500 001 383	RT 5/2001 500 001 384	– –

¹⁾ Including external frequency converter

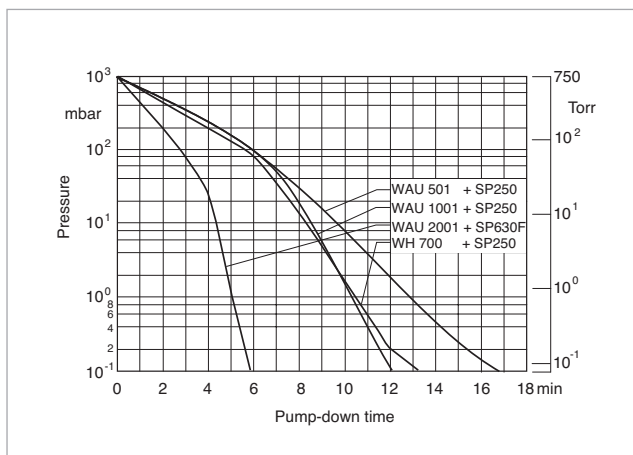

Pump-down time diagram for a 10 m³ tank at 50 Hz

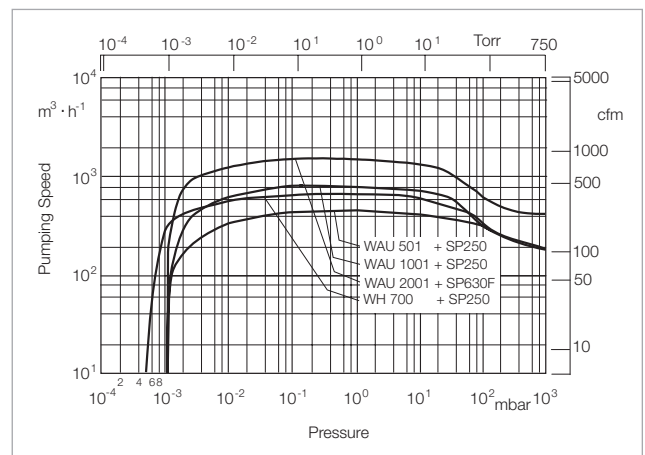

Pumping speed diagram at 50 Hz

Dry Compressing Vacuum Pump System RUTA with SCREWLINE Backing Pump, Adaptor Version, with palette



RUTA WAU2001/SP630/A

Standard Equipment

- RUVAC WAU with air cooling
- Silencer
- SP-GUARD
- Manually operated gas ballast
- Gear oil collecting pan integrated within the screw pump
- Gear oil supplied with the pump
- Screw pump SCREWLINE SP 630 F with water cooling

- Screw pump SCREWLINE SP 250 with air cooling
- CE approval

- Castors
- Different types of floor mounts
- Oil drain valve on each pump
- Electric control systems

Options

- Condensate drain valve at the silencer
- Sound proofing box
- Vibration absorbers

- Non-return valve
- Screw pump SCREWLINE SP 630 with air cooling

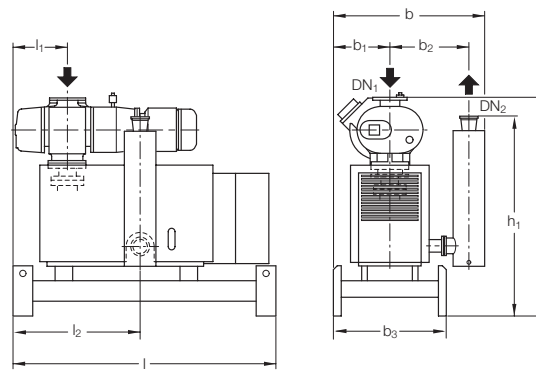

Type		with palette		
RUVAC WA/WAU/WS/WSU	RUTA P2	501/SP250/A 501	1001/SP250/A 1001	2001/SP630F/A 2001
Backing pump SCREWLINE	P1	SP 250	SP 250	SP 630 F
	DN ₁	63 ISO-K	100 ISO-K	160 ISO-K
	DN ₂	63 ISO-K	63 ISO-K	100 ISO-K
	l	1448 (57.01)	1488 (58.58)	1850 (72.84)
	l ₁	287 (11.30)	327 (12.87)	379 (14.92)
	l ₂	581 (22.87)	621 (24.45)	894 (35.20)
	b	923 (36.34)	923 (36.34)	1056 (41.58)
	b ₁	400 (15.75)	400 (15.75)	400 (15.75)
	b ₂	438 (17.24)	438 (17.24)	546 (21.50)
	b ₃	800 (31.50)	800 (31.50)	800 (31.50)
	h	1377 (54.21)	1403 (55.24)	1509 (59.41)
	h ¹	1121 (44.13)	1121 (44.13)	1388 (54.65)

Dimensional drawing of the pump systems with dry compressing SCREWLINE SP backing pump, adaptor version; left and middle with palette, right on castors
Dimensions in brackets () are in inch

Technical Data, 50 Hz

RUTA WAU

		501/SP250/A	1001/SP250/A	2001/SP630(F)/A
RUVAC (WA/WAU/WS/WSU possible)	P2	501	1001	2001
Backing pump SCREWLINE	P1	SP 250	SP 250	SP 630 (F)
Pumping speed, 50 Hz at 10^{-1} mbar (7.5×10^{-2} Torr)	m^3/h (cfm)	445.0 (262.1)	830.0 (488.9)	1745.0 (1027.8)
Ultimate total pressure without gas ballast	mbar (Torr)	$< 1 \times 10^{-3}$ ($< 7.5 \times 10^{-4}$)	$< 1 \times 10^{-3}$ ($< 7.5 \times 10^{-4}$)	$< 1 \times 10^{-3}$ ($< 7.5 \times 10^{-4}$)
Installed motor power 400 V, 50 Hz	kW (hp)	9.7 (13.2)	11.5 (15.6)	22.5 (30.6)
Electrical power consumption at 10^{-1} mbar (7.5×10^{-2} Torr)	kW (hp)	6.3 (8.6)	6.7 (9.1)	12.0 (16.3)
Noise level with silencer at 10^{-1} mbar (7.5×10^{-2} Torr)	dB(A)	75	77	79
Total weight with palette, approx.	kg (lbs)	720.0 (1589.4)	850.0 (1876.4)	1100.0 (2428.3)
Connecting flange				
Inlet port	DN ₁	63 ISO-K	100 ISO-K	160 ISO-K
Outlet port	DN ₂	63 ISO-K	63 ISO-K	100 ISO-K

Ordering Information

RUTA WAU

		501/SP250/A	1001/SP250/A	2001/SP630(F)/A
		Part No.	Part No.	Part No.
RUVAC (WA/WAU/WS/WSU possible)	P2	WAU 501	WAU 1001	WAU 2001
Backing pump SCREWLINE	P1	SP 250	SP 250	SP 630 (F)
Pump system, complete (adaptor version), pallet mounted, with water-cooled SCREWLINE		-	-	502 472 V002
with air-cooled SCREWLINE		502 466 V001	502 468 V001	502 472 V003
Frequency converter RUVATRONIC (see description in Chapter "Accessories")		RT 5/501 500 001 382	RT 5/1001 500 001 383	RT 5/2001 500 001 384

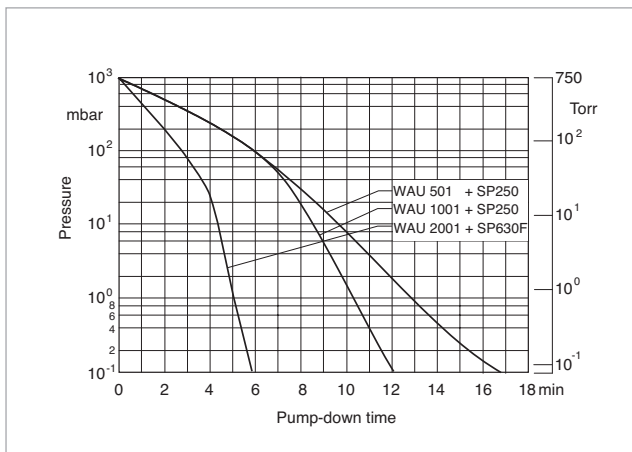

Pump-down time diagram for a 10 m³ tank at 50 Hz

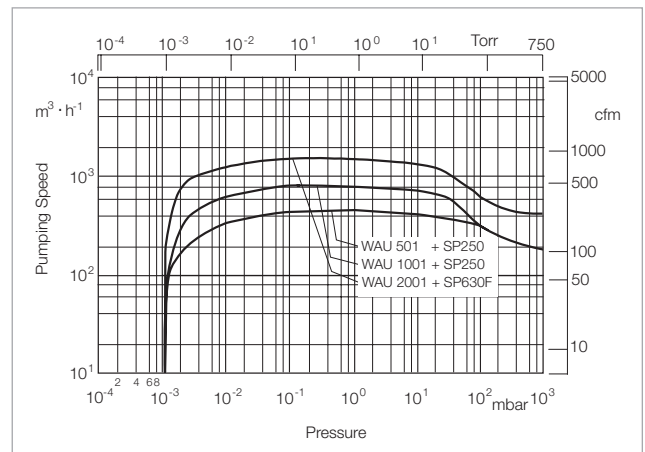

Pumping speed diagram at 50 Hz

Dry Compressing Vacuum Pump System RUTA with SCREWLINE Backing Pump, Adaptor Version, with palette

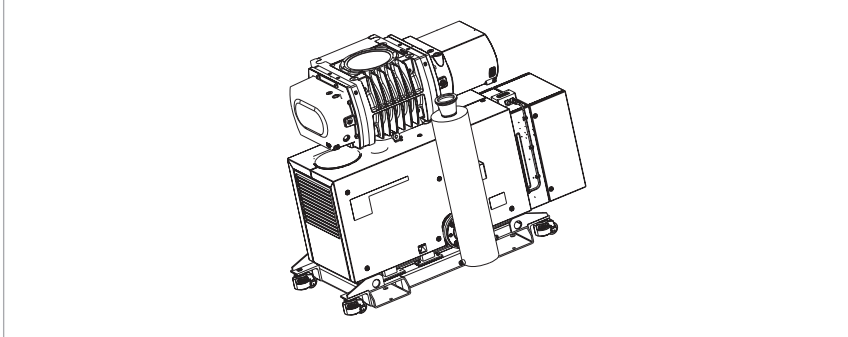

RUTA WH4400/SP630F/A on castors

Standard Equipment

- RUVAC WH with water cooling
- Silencer
- SP-GUARD
- Manually operated gas ballast
- Gear oil collecting pan integrated within the screw pump
- Gear oil supplied with the pump
- Screw pump SCREWLINE SP 630 F with water cooling
- RUVAC WH including external frequency converter (frequency converter permits pumping speed control)
- CE approval
- Sound proofing box
- Vibration absorbers
- Castors
- Different types of floor mounts
- Oil drain valve on each pump
- Electric control systems
- Non-return valve
- Screw pump SCREWLINE SP 630 with air cooling

Options

- Condensate drain valve at the silencer

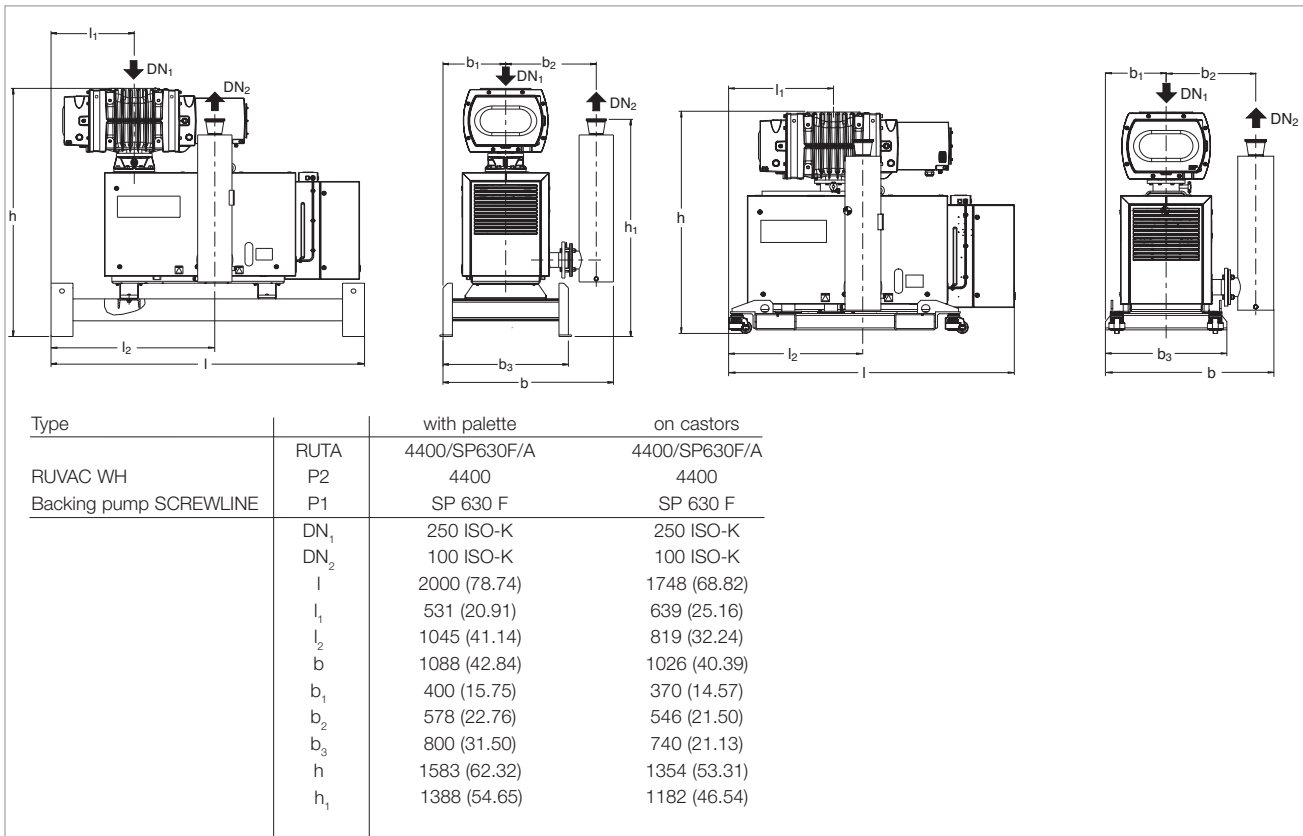

Dimensional drawing of the pump systems with dry compressing SCREWLINE SP backing pump, adaptor version; left with palette, right on castors. Dimensions in brackets () are in inch

Technical Data, 50 Hz

RUTA WH 4400/SP630F/A

RUVAC WH	P2	4400
Backing pump SCREWLINE	P1	SP 630 F
Pumping speed, 50 Hz at 10^{-1} mbar (7.5×10^{-2} Torr)	m^3/h (cfm)	3380 (1990)
Ultimate total pressure without gas ballast	mbar (Torr)	$< 1 \times 10^{-3}$ ($< 7.5 \times 10^{-4}$)
Installed motor power 400 V, 50 Hz	kW (hp)	26.0 (34.9)
Electrical power consumption at 10^{-1} mbar (7.5×10^{-2} Torr)	kW (hp)	12.93 (17.34)
Noise level with silencer at 10^{-1} mbar (7.5×10^{-2} Torr)	dB(A)	73
Total weight with palette, approx.	kg (lbs)	1350 (2932)
on castors, approx.	kg (lbs)	1980 (4365)
Connecting flange		
Inlet port	DN ₁	250 ISO-K
Outlet port	DN ₂	100 ISO-K

Ordering Information

RUTA WH 4400/SP630F/A

		Part No.
RUVAC WH	P2	4400
Backing pump SCREWLINE	P1	SP 630 F
Pump system, complete (adaptor version), with water-cooled SCREWLINE pallet mounted		503 162 V001 ¹⁾
castor mounted		502 873 V001 ¹⁾

¹⁾ Including external frequency converter

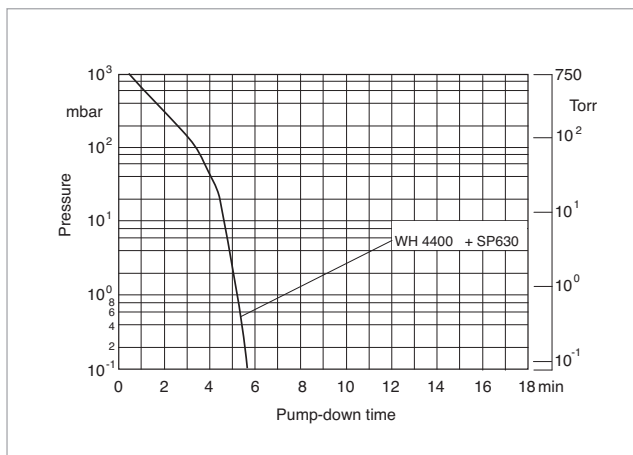

Pump-down time diagram for a 10 m³ tank at 50 Hz

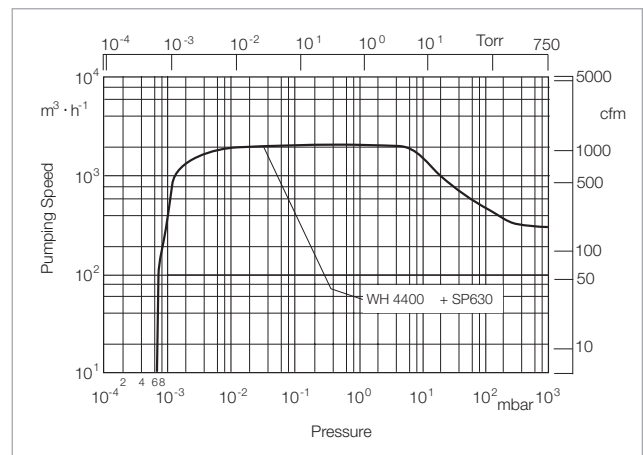

Pumping speed diagram at 50 Hz

Dry Compressing Vacuum Pump System RUTA with SCREWLINE SP 250 Backing Pump, Frame Version



RUTA WAU2001/SP630/G

Standard Equipment

- RUVAC WH with water cooling
- RUVAC WAU with air cooling
- SCREWLINE SP 250 with air cooling
- Silencer
- SP-GUARD
- Manually operated gas ballast
- SECUVAC valve 24 V DC
- Gear oil collecting pan integrated within the screw pump

- Crane eyes on the frame
- Floor mounting
- Gear oil supplied with the pump
- Screw pump with air cooling
- RUVAC WH including external frequency converter (frequency converter permits pumping speed control)
- CE approval

Options

- Condensate drain valve at the silencer
- Sound proofing box
- Vibration absorbers
- Castors
- Different types of floor mounts
- Oil drain valve on each pump
- Electric control systems
- Non-return valve

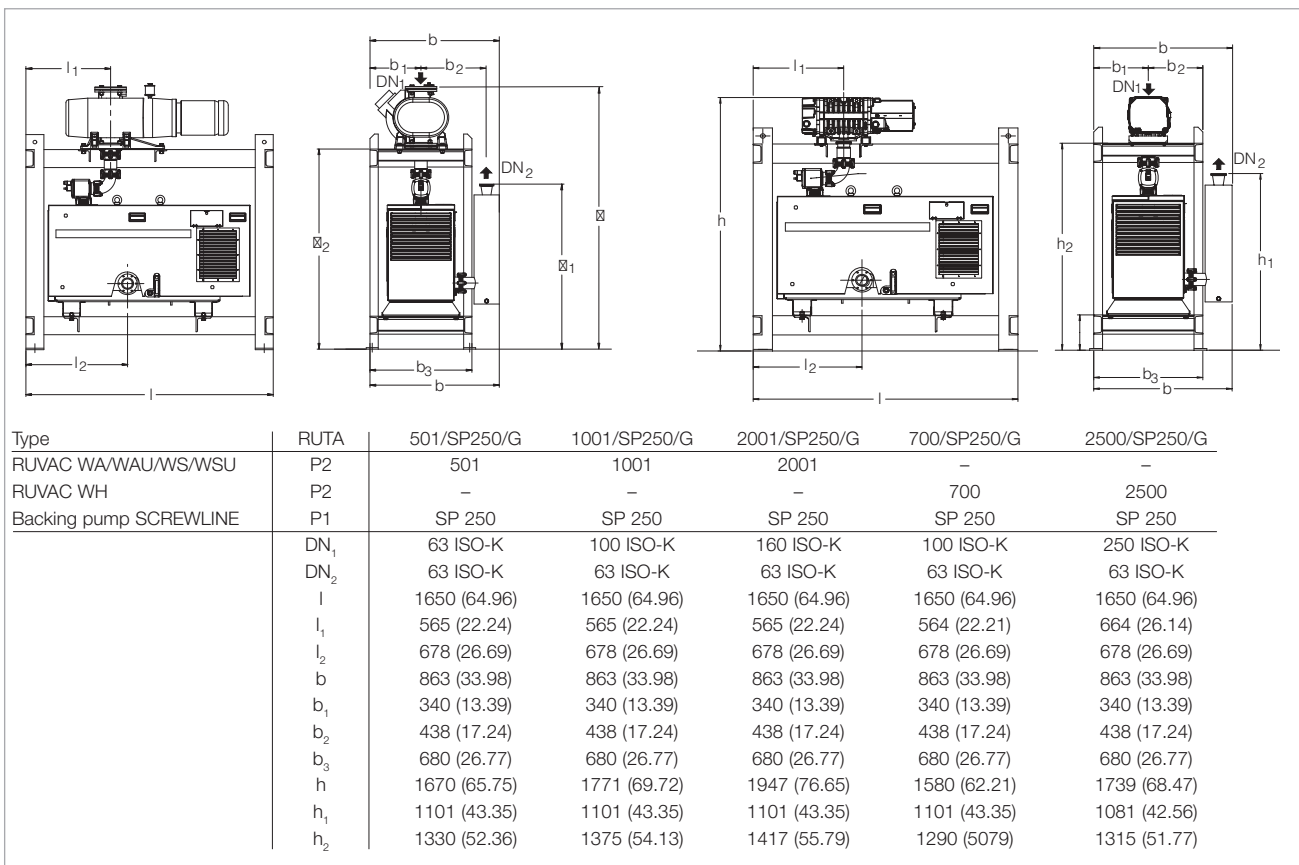

Dimensional drawing of the pump systems with dry compressing SCREWLINE SP 250 backing pump, frame version; dimensions in brackets () are in inch

Technical Data, 50 Hz

		WAU 501/ SP250/G	WAU 1001/ SP250/G	RUTA WAU 2001/ SP250/G	WH 700/ SP250/G	WH 2500/ SP250/G
RUVAC (WA/WAU/WS/WSU possible)	P2	501	1001	2001	–	–
RUVAC WH	P2	–	–	–	700	2500
Backing pump SCREWLINE	P1	SP 250	SP 250	SP 250	SP 250	SP 250
Pumping speed, 50 Hz at 10 ⁻¹ mbar (7.5 x 10 ⁻² Torr)	m ³ /h (cfm)	445 (262)	830.0 (489)	1530 (901)	635 (374)	1680 (988)
Ultimate total pressure without gas ballast	mbar (Torr)	< 1 x 10 ⁻³ (< 0.75 x 10 ⁻³)	< 1 x 10 ⁻³ (< 0.75 x 10 ⁻³)	< 1 x 10 ⁻³ (< 0.75 x 10 ⁻³)	< 1 x 10 ⁻³ (< 0.75 x 10 ⁻³)	< 3 x 10 ⁻³ (< 2.2 x 10 ⁻³)
Installed motor power 400 V, 50 Hz	kW (hp)	9.7 (13.2)	11.5 (15.6)	15.0 (20.4)	9.7 (13.2)	13.5 (18.1)
Electrical power consumption at 10 ⁻¹ mbar (7.5 x 10 ⁻² Torr)	kW (hp)	6.3 (8.6)	6.7 (9.1)	7.6 (10.3)	6.6 (8.9)	7.3 (9.8)
Noise level with silencer at 10 ⁻¹ mbar (7.5 x 10 ⁻² Torr)	dB(A)	74	77	80	75	70
Weight, total, approx.	kg (lbs)	860 (1896)	950 (2097)	1140 (2517)	860 (1896)	1000 (2205)
Connecting flange Inlet port	DN ₁	63 ISO-K	100 ISO-K	160 ISO-K	100 ISO-K	250 ISO-K
Outlet port	DN ₂	63 ISO-K	63 ISO-K	63 ISO-K	63 ISO-K	63 ISO-K

Ordering Information

		WAU 501/ SP250/G	WAU 1001/ SP250/G	RUTA WAU 2001/ SP250/G	WH 700/ SP250/G	WH 2500/ SP250/G
		Part No.	Part No.	Part No.	Part No.	Part No.
RUVAC (WA/WAU/WS/WSU possible)	P2	WAU 501	WAU 1001	WAU 2001	–	–
RUVAC WH	P2	–	–	–	700	2500
Backing pump SCREWLINE	P1	SP 250	SP 250	SP 250	SP 250	SP 250
Pump system, complete (adaptor version), frame mounted, with Roots vacuum pump						
RUVAC WAU		502 531 V001	502 532 V001	502 533 V001	–	–
RUVAC WH		–	–	–	503 154 V001 ¹⁾	503 158 V001 ^{1, 2)}
Frequency converter RUVATRONIC (see description in Chapter “Accessories”)		RT 5/501	RT 5/1001	RT 5/2001	–	–
		500 001 382	500 001 383 ²⁾	500 001 384 ²⁾	–	–

¹⁾ Including external frequency converter

²⁾ With this combination, continuous operation of the Roots pump is not possible at atmospheric pressure

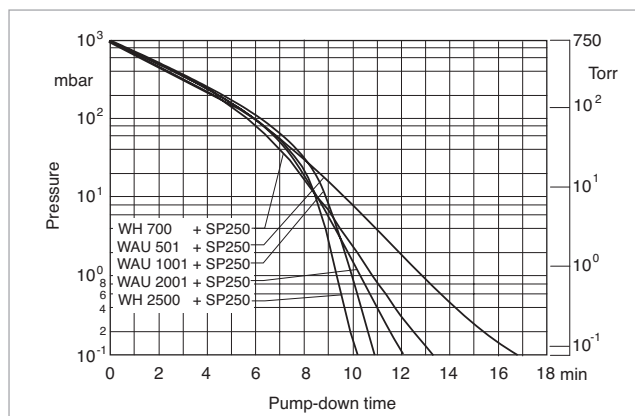

Pump-down time diagram for a 10 m³ tank at 50 Hz

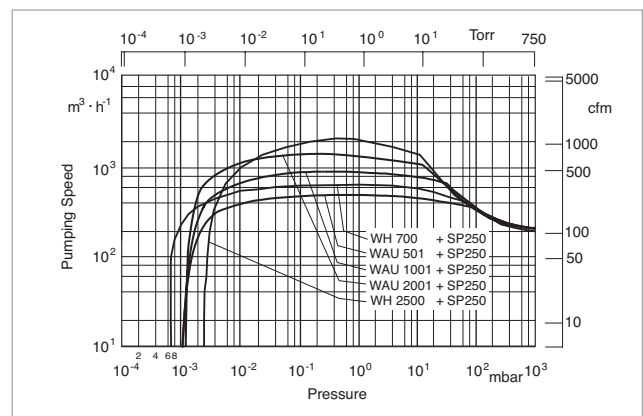

Pumping speed diagram at 50 Hz

Dry Compressing Vacuum Pump System RUTA with SCREWLINE SP 630 F Backing Pump, Frame Version



RUTA WAU2001/SP630F/G

Standard Equipment

- RUVAC RA with water cooling
- SCREWLINE SP 630 F with water cooling
- Silencer
- SP-GUARD
- Manually operated gas ballast
- SECUVAC valve 24 V DC
- Gear oil collecting pan integrated within the screw pump
- Crane eyes on the frame

- Floor mounting
- Gear oil supplied with the pump
- CE approval

Options

- Frequency converter RUVATRONIC RT for controlling the speed of the Roots pump
- Condensate drain valve at the silencer

- Sound proofing box
- Vibration absorbers
- Castors
- Different types of floor mounts
- Oil drain valve on each pump
- Electric control systems
- Non-return valve
- Screw pump with air cooling

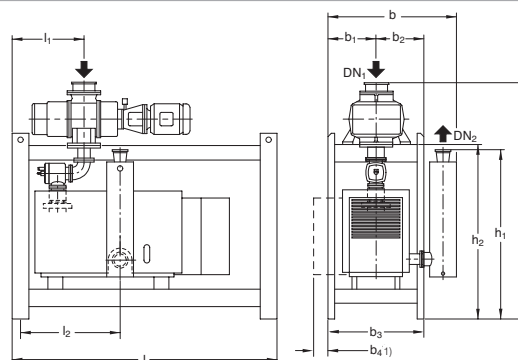

Type	RUTA	3001/SP630F/G	5001/SP630F/G	7001/SP630F/G	9001/SP630F/G
RUVAC RA	P2	3001	5001	7001	9001
Backing pump SCREWLINE	P1	SP 630 F	SP 630 F	SP 630 F	SP 630 F
	DN ₁	250 ISO-K	250 ISO-K	250 ISO-K	320 ISO-K
	DN ₂	100 ISO-K	100 ISO-K	100 ISO-K	100 ISO-K
	l	1960 (77.17)	2400 (94.49)	1960 (77.17)	2340 (92.13)
	l ₁	600 (23.62)	701 (27.60)	600 (23.62)	727 (28.62)
	l ₂	895 (35.24)	995 (39.17)	895 (35.24)	1021 (40.20)
	b	1056 (41.58)	1116 (43.94)	1116 (43.94)	1171 (46.10)
	b ₁	400 (15.75)	460 (18.11)	460 (18.11)	515 (20.28)
	b ₂	546 (21.50)	546 (21.50)	546 (21.50)	546 (21.50)
	b ₃	800 (31.50)	930 (36.61)	920 (36.22)	1030 (40.55)
	h	2025 (79.72)	2215 (87.21)	2156 (84.88)	2235 (87.99)
	h ₁	1388 (54.65)	1388 (54.65)	1388 (54.65)	1388 (54.65)
	h ₂	1411 (55.55)	1411 (55.55)	1411 (55.55)	1411 (55.55)

Dimensional drawing of the pump systems RUTA with dry compressing SCREWLINE SP 630 F backing pump, frame version; dimensions in brackets () are in inch

Technical Data, 50 Hz

RUTA RA

3001/SP630F/G 5001/SP630F/G 7001/SP630F/G 9001/SP630F/G

RUVAC RA	P2	3001	5001	7001	9001
Backing pump SCREWLINE	P1	SP 630 F	SP 630 F	SP 630 F	SP 630 F
Pumping speed, 50 Hz at 10^{-1} mbar (7.5×10^{-2} Torr)	m ³ /h (cfm)	3050 (1797)	4040.0 (2379.6)	5030 (2963)	6000 (3534)
Ultimate total pressure without gas ballast	mbar (Torr)	$< 1 \times 10^{-3}$ ($< 0.75 \times 10^{-3}$)	$< 1 \times 10^{-3}$ ($< 0.75 \times 10^{-3}$)	$< 1 \times 10^{-3}$ ($< 0.75 \times 10^{-3}$)	$< 1 \times 10^{-3}$ ($< 0.75 \times 10^{-3}$)
Installed motor power 400 V, 50 Hz	kW (hp)	26.0 (35.0)	30.0 (40.0)	33.5 (45.0)	37.0 (50.0)
Electrical power consumption at 10^{-1} mbar (7.5×10^{-2} Torr)	kW (hp)	13.4 (18.2)	13.5 (18.4)	13.6 (18.5)	13.2 (18.0)
Noise level with silencer at 10^{-1} mbar (7.5×10^{-2} Torr)	dB(A)	82	79	82	80
Weight, total, approx.	kg (lbs)	1550 (3420)	1900 (4190)	2000 (4410)	2630 (5800)
Connecting flange					
Inlet port	DN ₁	250 ISO-K	250 ISO-K	250 ISO-K	320 ISO-K
Outlet port	DN ₂	100 ISO-K	100 ISO-K	100 ISO-K	100 ISO-K

Ordering Information

RUTA RA

3001/SP630F/G 5001/SP630F/G 7001/SP630F/G 9001/SP630F/G

		Part No.	Part No.	Part No.	Part No.
RUVAC	P2	RA 3001	RA 5001	RA 7001	RA 9001
Backing pump SCREWLINE	P1	SP 630 F	SP 630 F	SP 630 F	SP 630 F
Pump system, complete (adaptor version), frame mounted, with Roots vacuum pump RUVAC RA with air-cooled vacuum pump Screw pump SCREWLINE SP 630		502 512 V001	502 513 V001	502 514 V001	502 515 V001
Frequency converter RUVATRONIC (see description in Chapter "Accessories")		RT 5/3001 500 001 385 ¹⁾	RT 5/5001 500 001 386 ¹⁾	RT 5/7001 500 001 387 ¹⁾	RT 5/9001 500 001 388 ¹⁾

¹⁾ With this combination, continuous operation of the Roots pump is not possible at atmospheric pressure

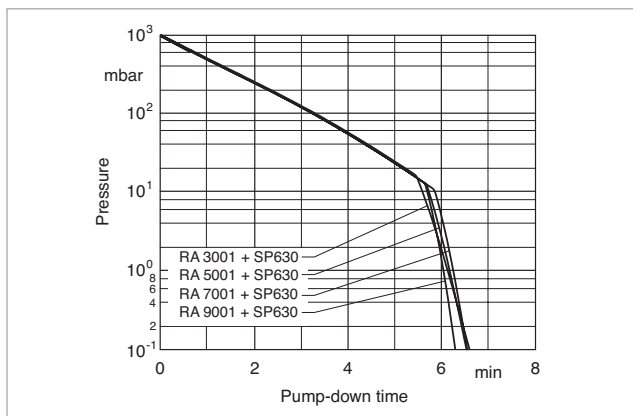

Pump-down time diagram for a 10 m³ tank at 50 Hz

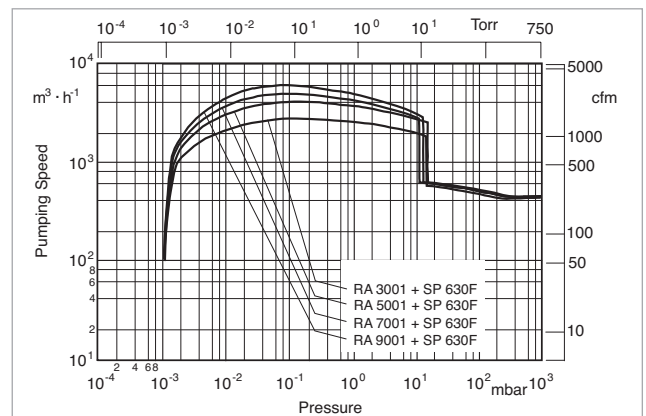

Pumping speed diagram at 50 Hz

Dry Compressing Vacuum Pump System RUTA with SCREWLINE SP 630 F Backing Pump, Frame Version



RUTA WAU2001/SP630F/G

Standard Equipment

- RUVAC WH with water cooling
- RUVAC WAU with air cooling
- SCREWLINE SP 630 F with water cooling
- Silencer
- SP-GUARD
- Manually operated gas ballast
- SECUVAC valve 24 V DC
- Gear oil collecting pan integrated within the screw pump
- Crane eyes on the frame
- Floor mounting
- Gear oil supplied with the pump
- RUVAC WH including external frequency converter (frequency converter permits pumping speed control)
- CE approval
- Condensate drain valve at the silencer
- Sound proofing box
- Vibration absorbers
- Different types of floor mounts
- Oil drain valve on each pump
- Electric control systems
- Non-return valve
- Screw pump with air cooling

Options

- Frequency converter for controlling the speed of the Roots pump (only RUVAC RA/WA/WS)

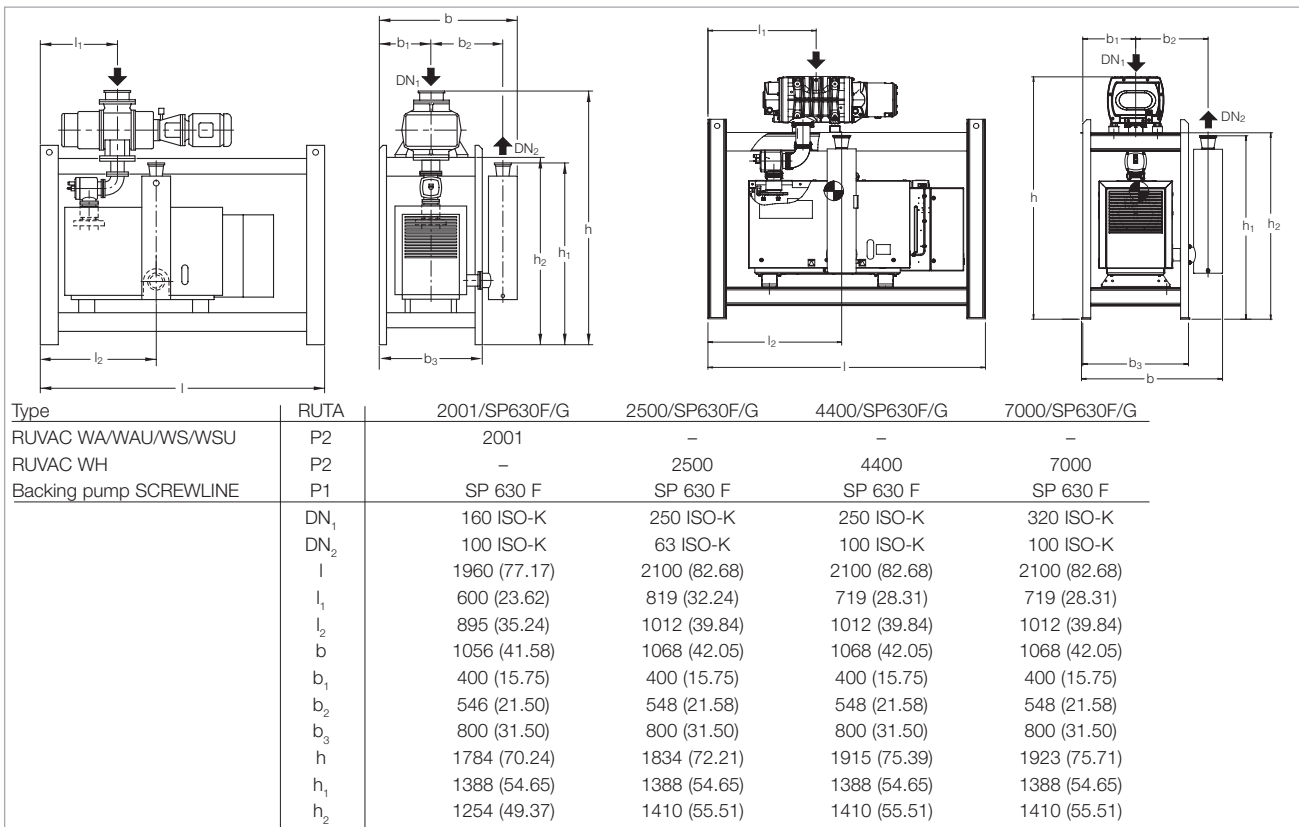

Dimensional drawing of the pump systems RUTA with dry compressing SCREWLINE SP 630 F backing pump, frame version; dimensions in brackets () are in inch

Technical Data, 50 Hz

RUTA

		WAU 2001/SP630F/G	WH 2500/SP630F/G	WH 4400/SP630F/G	WH 7000/SP630F/G
RUVAC (WA/WAU/WS/WSU possible)	P2	2001	–	–	–
RUVAC WH	P2	–	2500	4400	7000
Backing pump SCREWLINE	P1	SP 630 F	SP 630 F	SP 630 F	SP 630 F
Pumping speed, 50 Hz at 10^{-1} mbar (7.5×10^{-2} Torr)	m^3/h (cfm)	1745 (1028)	1956 (1151)	3380 (1990)	5093 (2998)
Ultimate total pressure without gas ballast	mbar (Torr)	$< 1 \times 10^{-3}$ ($< 0.75 \times 10^{-3}$)	$< 5 \cdot 10^{-3}$ ($< 3.7 \times 10^{-3}$)	$< 1 \times 10^{-3}$ ($< 0.75 \times 10^{-3}$)	$< 1 \times 10^{-3}$ ($< 0.75 \times 10^{-3}$)
Installed motor power 400 V, 50 Hz	kW (hp)	22.5 (30.0)	21.5 (28.8)	26.0 (34.9)	26.0 (34.9)
Electrical power consumption at 10^{-1} mbar (7.5×10^{-2} Torr)	kW (hp)	12.0 (16.3)	11.7 (16.7)	12.93 (17.34)	13.11 (17.58)
Noise level with silencer at 10^{-1} mbar (7.5×10^{-2} Torr)	dB(A)	79	73	73	73
Weight, total, approx.	kg (lbs)	1300 (2866)	1300 (2866)	1550 (3417)	1600 (3527)
Connecting flange					
Inlet port	DN ₁	160 ISO-K	250 ISO-K	250 ISO-K	320 ISO-K
Outlet port	DN ₂	100 ISO-K	63 ISO-K	100 ISO-K	100 ISO-K

Ordering Information

RUTA

		WAU 2001/SP630F/G	WH 2500/SP630F/G	WH 4400/SP630F/G	WH 7000/SP630F/G
	Part No.	Part No.	Part No.	Part No.	Part No.
RUVAC (WA/WAU/WS/WSU possible)	P2	WAU 2001	–	–	–
RUVAC WH	P2	–	2500	4400	7000
Backing pump SCREWLINE	P1	SP 630 F	SP 630 F	SP 630 F	SP 630 F
Pump system, complete (adaptor version), frame mounted, with Roots vacuum pump RUVAC WAU		502 511 V001	–	–	–
with Roots vacuum pump RUVAC WH		–	503 159 V001 ^{1), 2)}	503 163 V001 ^{1), 2)}	503 168 V001 ^{1), 2)}
Frequency converter RUVATRONIC (see description in Chapter “Accessories”)		RT 5/2001 500 001 384	–	–	–

¹⁾ Including external frequency converter

²⁾ With this combination, continuous operation of the Roots pump is not possible at atmospheric pressure

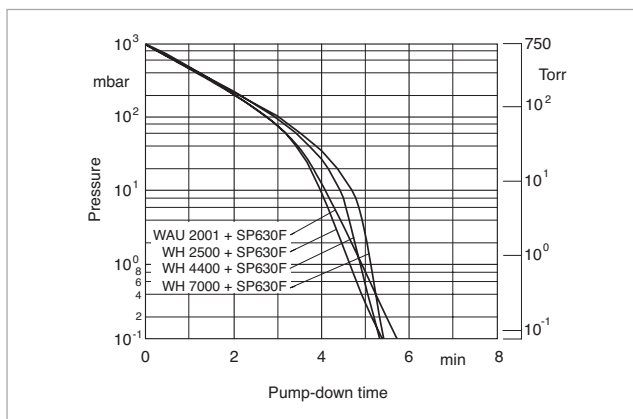

Pump-down time diagram for a 10 m³ tank at 50 Hz

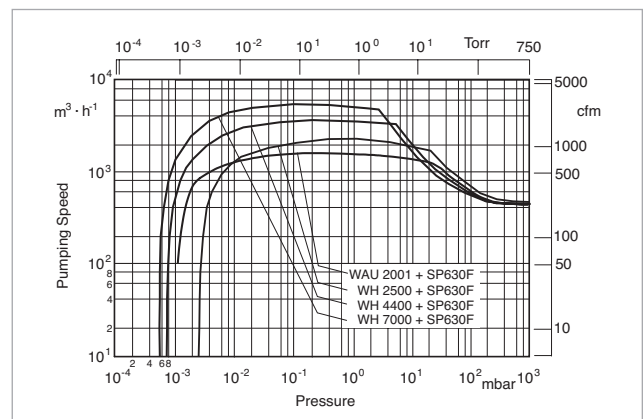

Pumping speed diagram at 50 Hz

Dry Compressing Vacuum Pump System RUTA with SCREWLINE SP 630 F Backing Pump, Adaptor Version

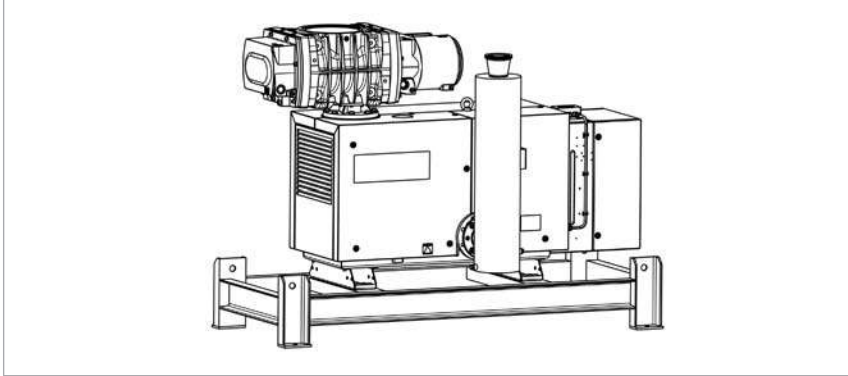

RUTA WH2500/SP630F/A

Standard Equipment

- RUVAC WH with water cooling
- SCREWLINE SP 630 F with water cooling
- Silencer
- SP-GUARD
- Manually operated gas ballast
- SECUVAC valve 24 V DC
- Gear oil collecting pan integrated within the screw pump
- Crane eyes on the frame
- Floor mounting
- Gear oil supplied with the pump
- RUVAC WH including external frequency converter (frequency converter permits pumping speed control)
- Sound proofing box
- Vibration absorbers
- Different types of floor mounts
- Oil drain valve on each pump
- Electric control systems
- Non-return valve
- Screw pump with air cooling

Options

- Condensate drain valve at the silencer

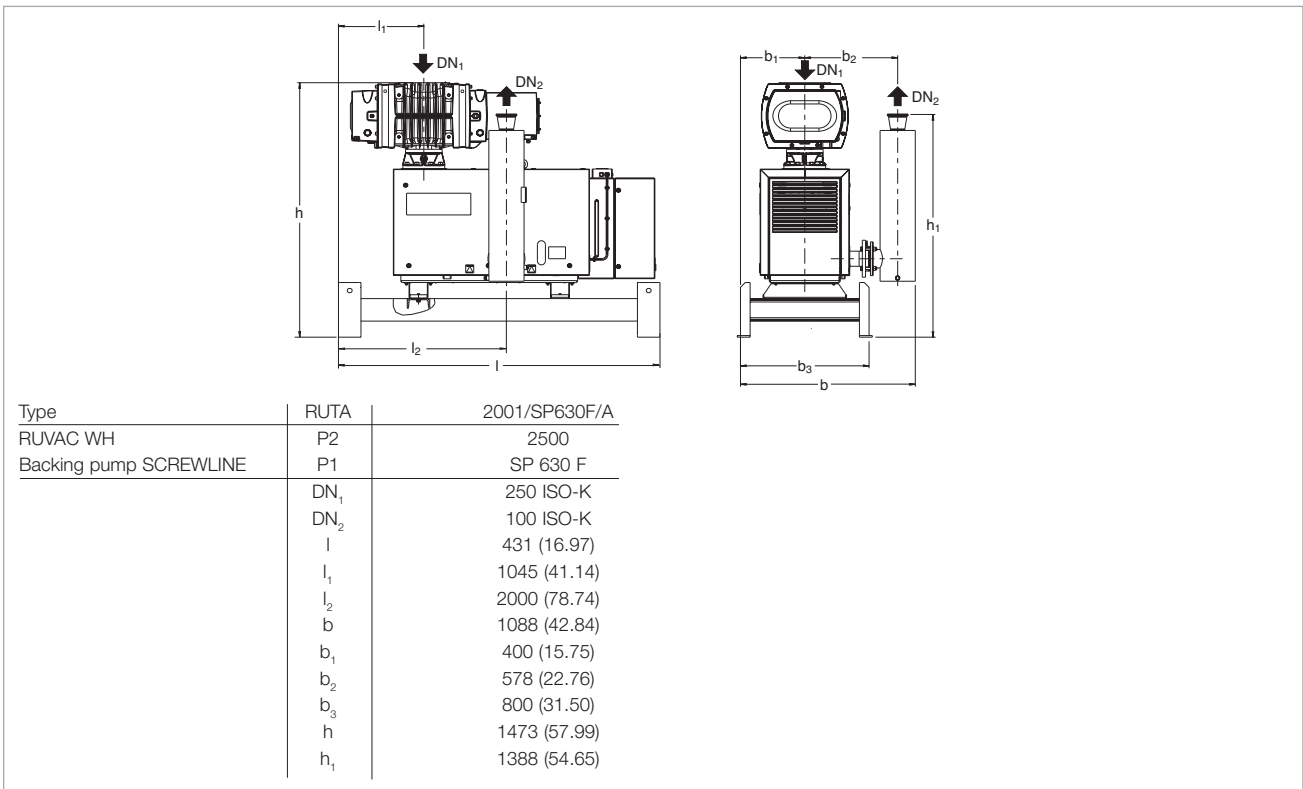

Dimensional drawing of the pump system with dry compressing SCREWLINE SP 630 F backing pump, adaptor version; dimensions in brackets () are in inch

Technical Data, 50 Hz

RUTA WH 2500/SP630F/A

RUVAC WH	P2	2500
Backing pump SCREWLINE	P1	SP 630 F
Pumping speed, 50 Hz at 10 ⁻¹ mbar (7.5 x 10 ⁻² Torr)	m ³ /h (cfm)	1956 (1151)
Ultimate total pressure without gas ballast	mbar (Torr)	< 5 x 10 ⁻³ (< 3.7 x 10 ⁻³)
Installed motor power 400 V, 50 Hz	kW (hp)	21.5 (28.8)
Electrical power consumption at 10 ⁻¹ mbar (7.5 x 10 ⁻² Torr)	kW (hp)	11.7(16.7)
Noise level with silencer at 10 ⁻¹ mbar (7.5 x 10 ⁻² Torr)	dB(A)	73
Weight, total, approx.	kg (lbs)	1200 (2645)
Connecting flange		
Inlet port	DN ₁	250 ISO-K
Outlet port	DN ₂	100 ISO-K

Ordering Information

RUTA WH 2500/SP630F/A

		Part No.
RUVAC WH	P2	2500
Backing pump SCREWLINE	P1	SP 630 F
Pump system, complete (adaptor version), pallet mounted, with Roots vacuum pump RUVAC WH		503 160 V001 ¹⁾

¹⁾ Including external frequency converter

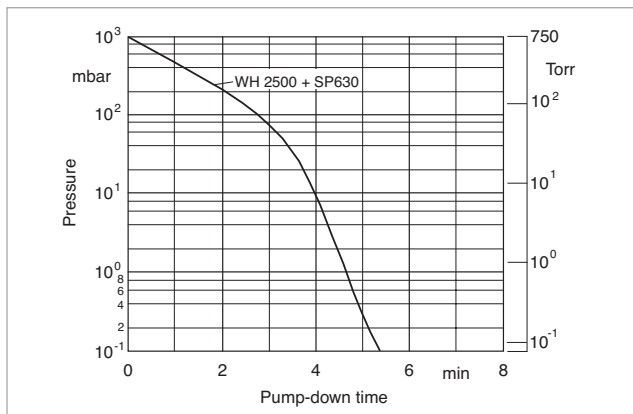

Pump-down time diagram for a 10 m³ tank at 50 Hz

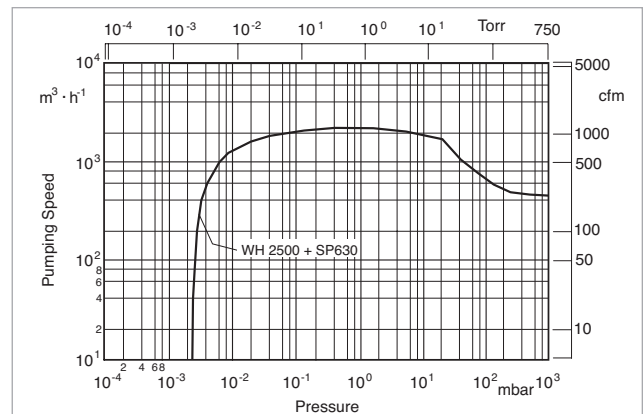

Pumping speed diagram at 50 Hz

Pump Systems (Only available for purchase in North and South America)

SP Close-Coupled Systems with SP Dry Compressing Backing Pumps

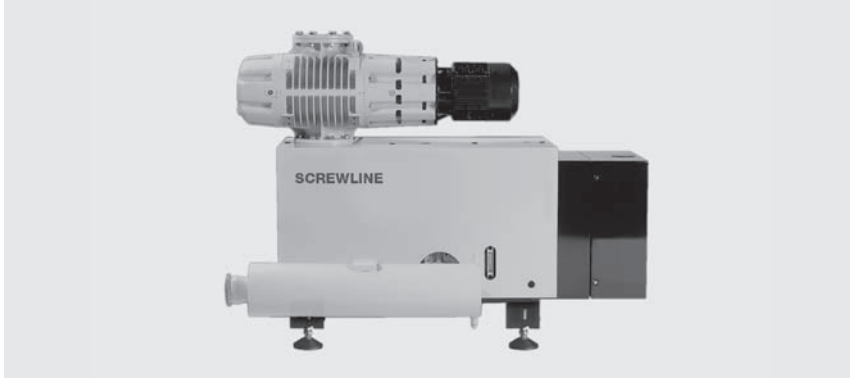

SP close-coupled system

Advantages to the User

- Reduced maintenance and lower operating costs
- Compact close-coupled design without frame
- Oil-free compression in multiple pump stages
- Optimum leak tightness with WSU boosters
- Air-cooled
- Assembled and tested

Standard Equipment

- SCREWLINE SP 630 / WSU 1001 close-coupled pump system offering 645 ACFM at 0.3 Torr vacuum
- SCREWLINE SP 630 / WSU2001 close-coupled pump system offering 1235 ACFM at 0.3 Torr vacuum

Options

- Electrical controls
- Exhaust silencer (loose)
- Inlet filter (loose)

The screw pump SCREWLINE SP 630 dry compressing screw-type vacuum pump is an environmentally friendly alternative to traditional oil sealed rotary piston and vane vacuum pumps. This innovative and robust vacuum pump produces a pumping speed of 371 cfm and better than 0.0075 Torr vacuum. SP 630 major advantages include improved environment, reduced maintenance, lower operating costs through less disposal and the elimination of expensive water cooling all with no oil contamination as the need for lubricating oil in the pumps' compression stage has been eliminated.

When used in conjunction with the Leybold WSU booster pumps, pumping speeds can be significantly increased while achieving oil-free compression in multiple vacuum pump stages.

Leybold WSU boosters offer a canned motor design, which eliminates the need for shaft seals and flanged-on motors. A vacuum tight can separates the motor rotor and stator coils. This unique Leybold design provides the advantage of a more leak tight vacuum system. The WSU version booster incorporates a by-pass valve feature, which allows for automatic adjustment to varying pressure differentials between the inlet and outlet of the pump. The result is elimination of costly pressure switches/ amplifiers and faster pump down while starting at atmospheric pressure with the aforementioned SP 630 vacuum pump.

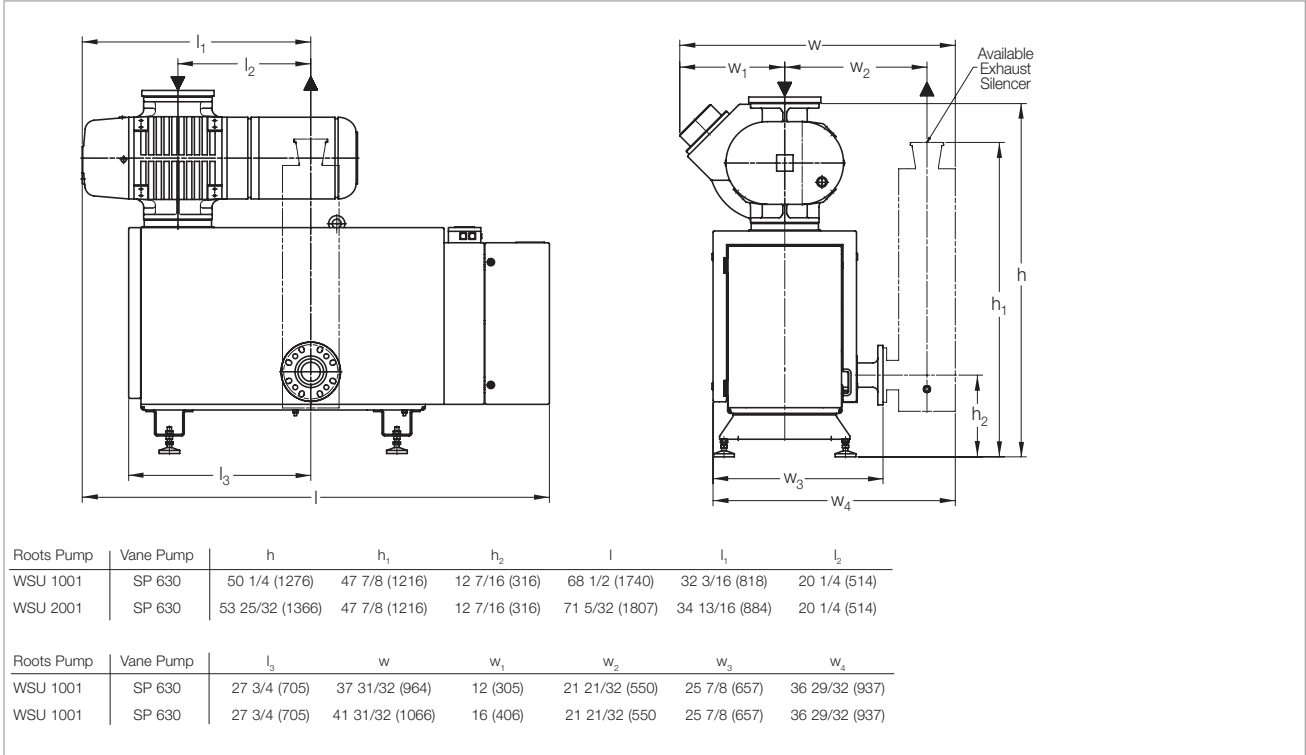

Dimensional drawing for the SP close-coupled system with SCREWLINE SP 630 dry compressing backing pumps; dimensions in brackets () are in mm

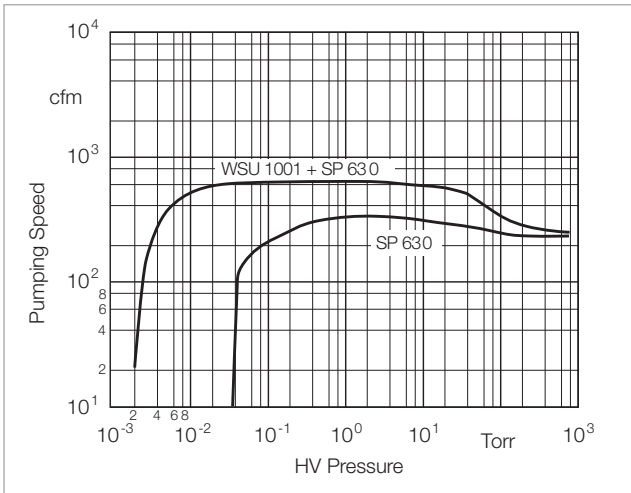

Pumping speed diagram for the SP close-coupled system with WSU 1001 Roots blower and SCREWLINE SP 630 at 60 Hz

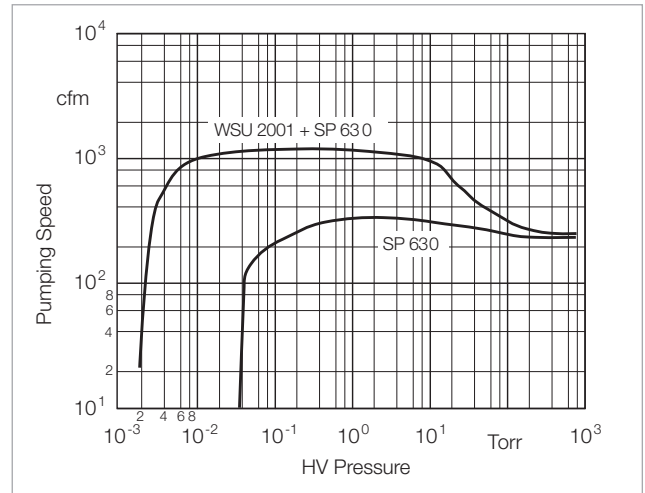

Pumping speed diagram for the SP close-coupled system with WSU 2001 Roots blower and SCREWLINE SP 630 at 60 Hz

Technical Data, 60 Hz

SP Close-Coupled Systems

1001/SP630

2001/SP630

RUVAC (WSU possible)	P2	1001	2001
Backing pump SCREWLINE	P1	SP 630	SP 630
Pumping speed 60 Hz at 0.3 Torr	m ³ /h (cfm)	1.092 (643)	2.085 (1,227)
Ultimate total pressure without gas ballast	mbar (Torr)	< 1 x 10 ⁻³ (< 7.5 x 10 ⁻⁴)	< 1 x 10 ⁻³ (< 7.5 x 10 ⁻⁴)
Installed motor power	kW (hp)	16.2 (21.6)	22.5 (30.0)
Noise level with silencer at 10 ⁻¹ mbar (7.5 x 10 ⁻² Torr)	dB(A)	78	79
Weight, total, approx.	kg (lbs)	870 (1922)	1100 (2430)
Connecting flange Inlet port	DN ₁	160 ISO-K	160 ISO-K
Outlet port	DN ₂	100 ISO-K	100 ISO-K

Ordering Information

SP Close-Coupled Systems

1001/SP630

2001/SP630

		Part No.	Part No.
RUVAC (WA/WAU/WS/WSU possible)	P2	WSU 1001	WSU 2001
Backing pump SCREWLINE	P1	SP 630	SP 630
Pump system, complete (adaptor version), pallet mounted, with Roots vacuum pump RUVAC WAU		180 038 V1600	180 038 V2600

Dry Compressing Vacuum Pump System RUTA with DRYVAC DV 650 Backing Pump, Adaptor Version

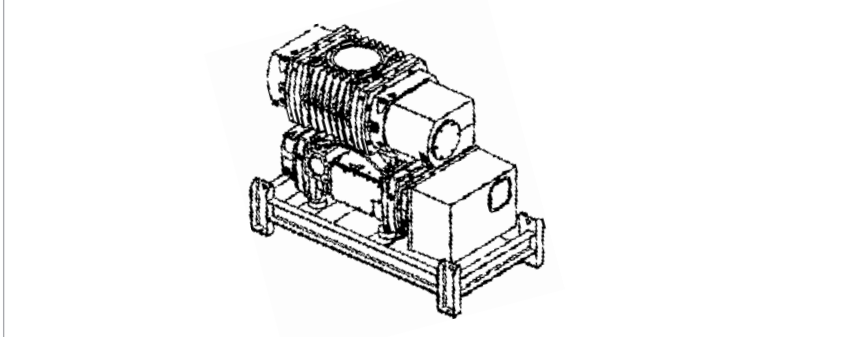

RUTA WH4400/DV650/A

Standard Equipment

- RUVAC WH and DRYVAC with water cooling
- DRYVAC DV with built-in frequency converter
- DRYVAC DV-r including external frequency converter
- RUVAC WH including external frequency converter (frequency converter permits pumping speed control)
- Hermetically sealed
- Integrated protection functions (discharge pressure, temperatures and current consumption)

- Innovative motor design with efficiency class IE2
- Gas ballast with manual valve
- Leak detection port
- Lubricant: synthetic oil (LVO 210)

Options

- Exhaust silencer
- Bus interface
- Non-return valve for DRYVAC

- Seal gas connection
- Gear chamber evacuation RUVAC WH
- Frequency converter for RUVAC pump
- Electrical controller
- Oil drain tap
- Cooling water monitoring
- Quick couplings for water connections, blocking on both sides
- Frame

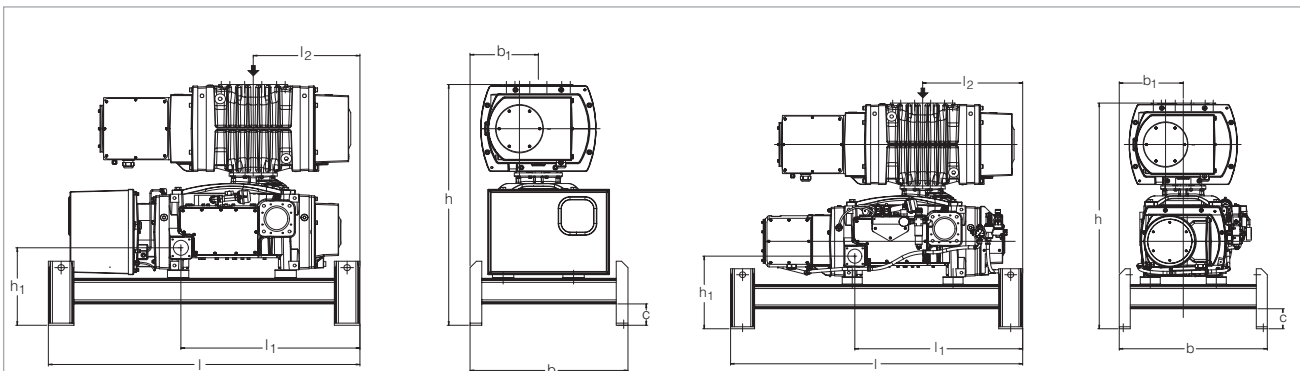

Type	RUTA	WH4400/DV650/A	WH4400/DV650-r/A
RUVAC WH	P2	4400	4400
Backing pump DRYVAC DV	P1	650	650-r
	DN ₁	250 ISO-K	250 ISO-K
	DN ₂	100 ISO-K	100 ISO-K
	l	1460 (57.48)	1460 (57.48)
	l ₁	839 (33.03)	839 (33.03)
	l ₂	500 (19.69)	500 (19.69)
	b	740 (29.13)	740 (29.13)
	b ₁	320 (12.60)	320 (12.60)
	c	100 (3.94)	100 (3.94)
	h	1128 (44.41)	1128 (44.41)
	h ₁	363 (14.29)	363 (14.29)

Dimensional drawing of the pump system with dry compressing DRYVAC DV 650 (left) and DV 650-r (right) backing pump, adaptor version; dimensions in brackets () are in inch

Technical Data, 50 Hz

RUTA WH

4400/DV650/A

4400/DV650-r/A

RUVAC WH	P2	4400	4400
Backing pump DRYVAC DV	P1	650	650-r
Pumping speed, 50 Hz at 10^{-1} mbar (7.5×10^{-2} Torr)	m^3/h (cfm)	3400 (2000)	3400 (2000)
Ultimate total pressure without gas ballast	mbar (Torr)	$< 5.0 \times 10^{-4}$ (3.8×10^{-4})	$< 5.0 \times 10^{-4}$ (3.8×10^{-4})
Installed motor power 400 V, 50 Hz	kW (hp)	26.0 (34.9)	26.0 (34.9)
Electrical power consumption at 10^{-1} mbar (7.5×10^{-2} Torr)	kW (hp)	9.3 (12.5)	9.3 (12.5)
Noise level with silencer at 10^{-1} mbar (7.5×10^{-2} Torr)	dB(A)	< 68	< 68
Weight, total, approx.	kg (lbs)	1550 (3417)	1550 (3417)
Connecting flange			
Inlet port	DN ₁	250 ISO-K	250 ISO-K
Outlet port	DN ₂	100 ISO-K	100 ISO-K

Ordering Information

RUTA WH

4400/DV650/A

4400/DV650-r/A

		Part No.	Part No.
RUVAC WH	P2	4400	4400
Backing pump DRYVAC DV	P1	650	650-r
Pump system, complete (adaptor version), pallet mounted, with Roots vacuum pump RUVAC WH		503 166 V001 ¹⁾	503 167 V001 ¹⁾

¹⁾ Including external frequency converter

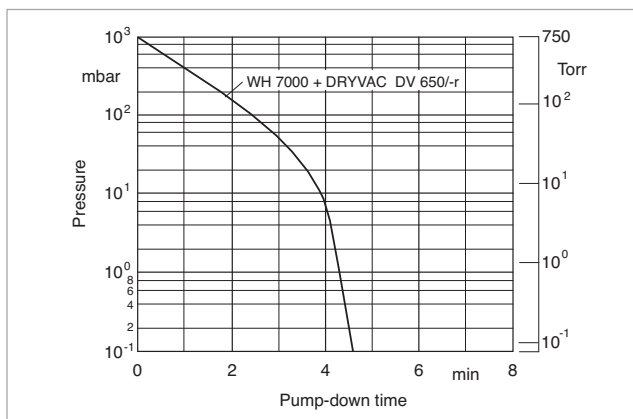

Pump-down time diagram for a 10 m^3 tank at 50 Hz

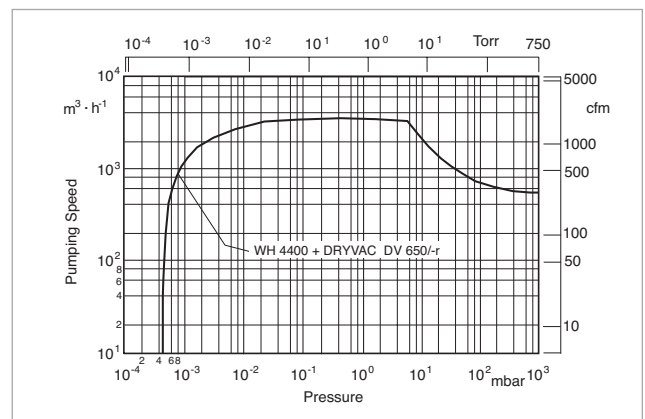

Pumping speed diagram at 50 Hz

Dry Compressing Vacuum Pump System RUTA with DRYVAC DV 650 Backing Pump, Frame Version

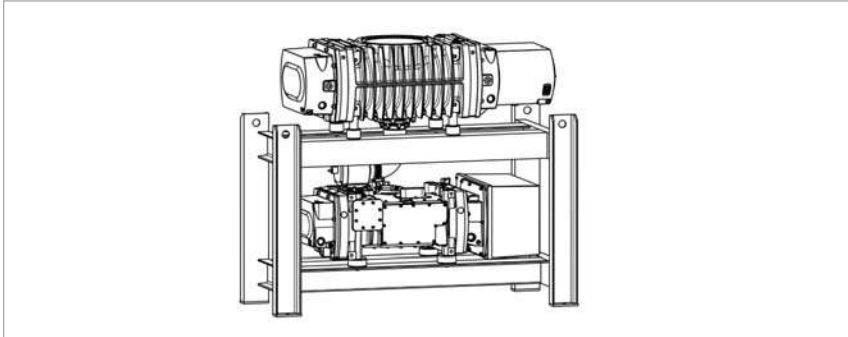

RUTA WH7000/DV650/G

Standard Equipment

- RUVAC WH and DRYVAC with water cooling
- DRYVAC DV with built-in frequency converter
- DRYVAC DV-r including external frequency converter
- RUVAC WH including external frequency converter (frequency converter permits pumping speed control)
- Hermetically sealed
- Integrated protection functions (discharge pressure, temperatures and current consumption)
- Innovative motor design with efficiency class IE2
- Gas ballast with manual valve
- Leak detection port
- Lubricant: synthetic oil (LVO 210)
- SECUVAC valve 24 V DC
- Gear chamber evacuation RUVAC WH
- Electrical controller
- Oil drain tap
- Cooling water monitoring
- Quick couplings for water connections, blocking on both sides

Options

- Exhaust silencer
- Bus interface
- Non-return valve for DRYVAC
- Seal gas connection

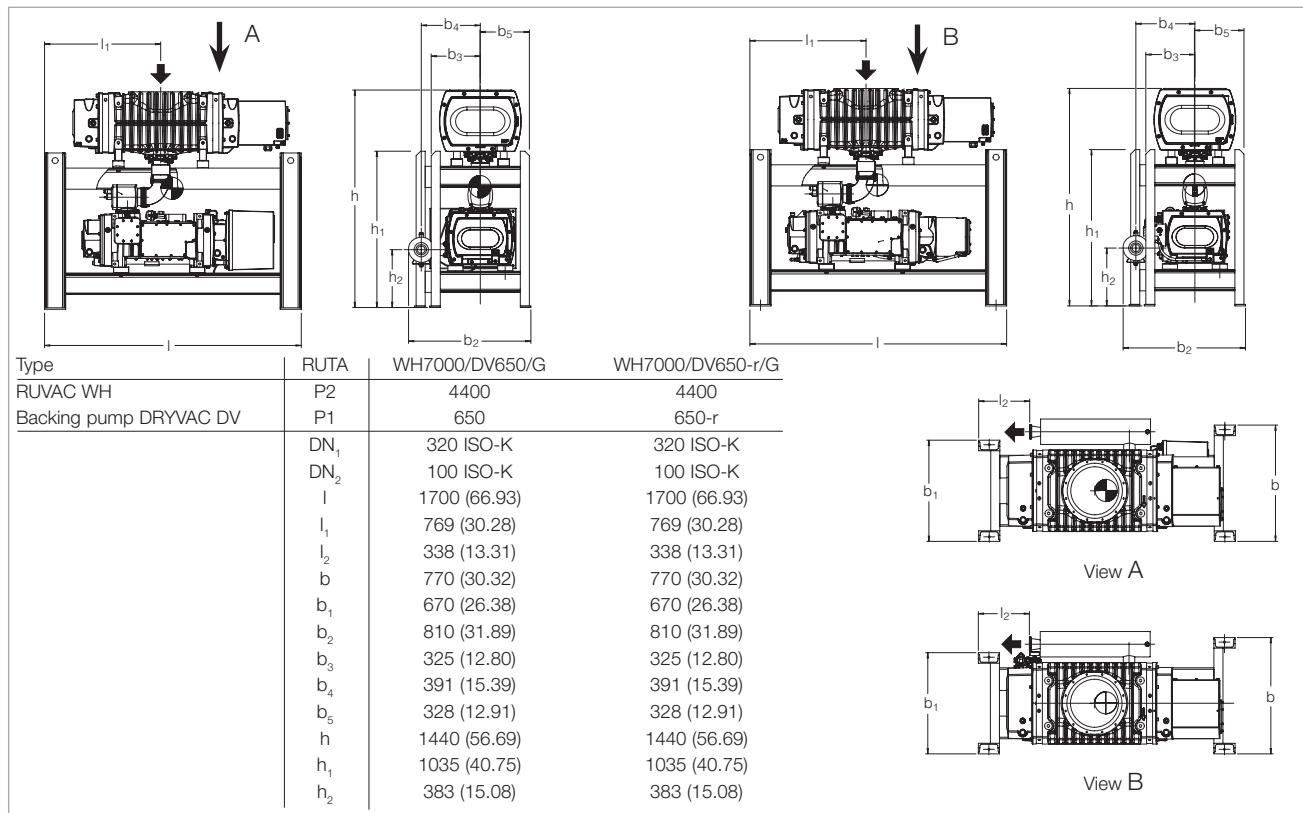

Dimensional drawing of the pump system with dry compressing DRYVAC DV 650 (left) and DV 650-r (right) backing pump, frame version; dimensions in brackets () are in inch; (shown with optional silencer)

Technical Data, 50 Hz

RUTA WH

7000/DV650/G

7000/DV650-r/G

RUVAC WH	P2	7000	7000
Backing pump DRYVAC DV	P1	650	650-r
Pumping speed, 50 Hz at 10^{-1} mbar (7.5×10^{-2} Torr)	m ³ /h (cfm)	5100 (3001)	5100 (3001)
Ultimate total pressure without gas ballast	mbar (Torr)	$< 5.0 \times 10^{-4}$ (3.8×10^{-4})	$< 5.0 \times 10^{-4}$ (3.8×10^{-4})
Installed motor power 400 V, 50 Hz	kW (hp)	26.0 (34.9)	26.0 (34.9)
Electrical power consumption at 10^{-1} mbar (7.5×10^{-2} Torr)	kW (hp)	9.36 (12.56)	9.36 (12.56)
Noise level with silencer at 10^{-1} mbar (7.5×10^{-2} Torr)	dB(A)	< 68	< 68
Weight, total, approx.	kg (lbs)	1600 (3527)	1600 (3527)
Connecting flange			
Inlet port	DN ₁	320 ISO-K	320 ISO-K
Outlet port	DN ₂	100 ISO-K	100 ISO-K

Ordering Information

RUTA WH

7000/DV650/G

7000/DV650-r/G

		Part No.	Part No.
RUVAC WH	P2	7000	7000
Backing pump DRYVAC DV	P1	650	650-r
Pump system, complete (adaptor version), frame mounted, with Roots vacuum pump RUVAC WH		503 170 V001 ¹⁾	503 171 V001 ¹⁾

¹⁾ Including external frequency converter

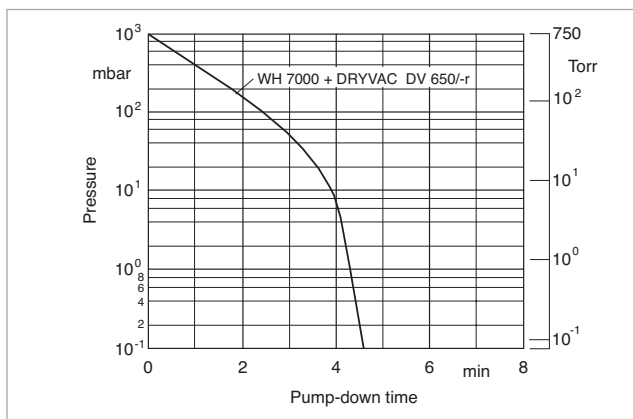

Pump-down time diagram for a 10 m³ tank at 50 Hz

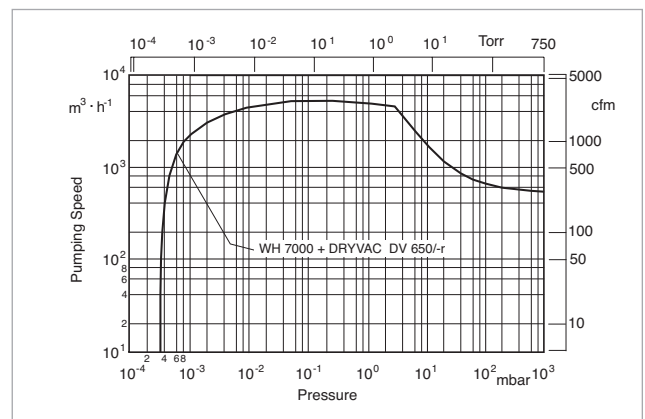

Pumping speed diagram at 50 Hz

Dry Compressing Vacuum Pump System RUTA with DRYVAC DV 1200 Backing Pump, Frame Version

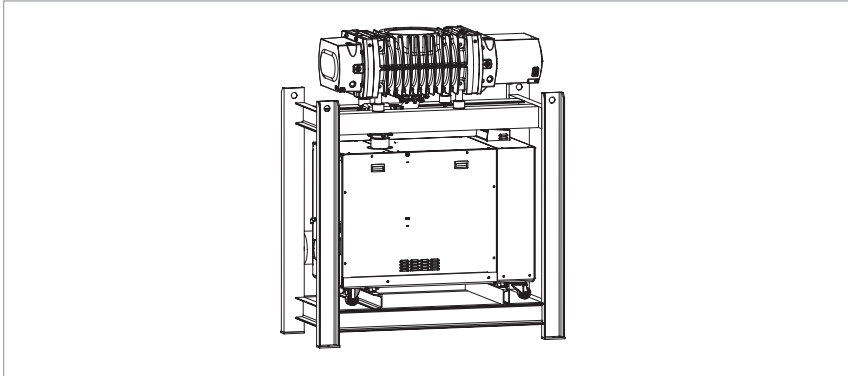

RUTA WH7000/DV1200/G

Standard Equipment

- RUVAC WH and DRYVAC with water cooling
- DRYVAC DV 1200 with built-in frequency converter
- RUVAC WH with water cooling and external frequency converter
- Hermetically sealed
- Integrated protection functions (discharge pressure, temperatures and current consumption)
- Innovative motor design with efficiency class IE2
- Gas ballast with electropneumatic valve 24 V DC
- Integrated valve 24 V DC for seal gas supply
- Leak detection port
- Control via Profibus (DRYVAC)
- Lubricant: synthetic oil (LVO 210)

Options

- Exhaust silencer
- Bus interface
- Non-return valve for DRYVAC
- Seal gas connection
- Gear chamber evacuation
- Electrical controller
- Oil drain tap
- Cooling water monitoring
- Quick couplings for water connections, blocking on both sides

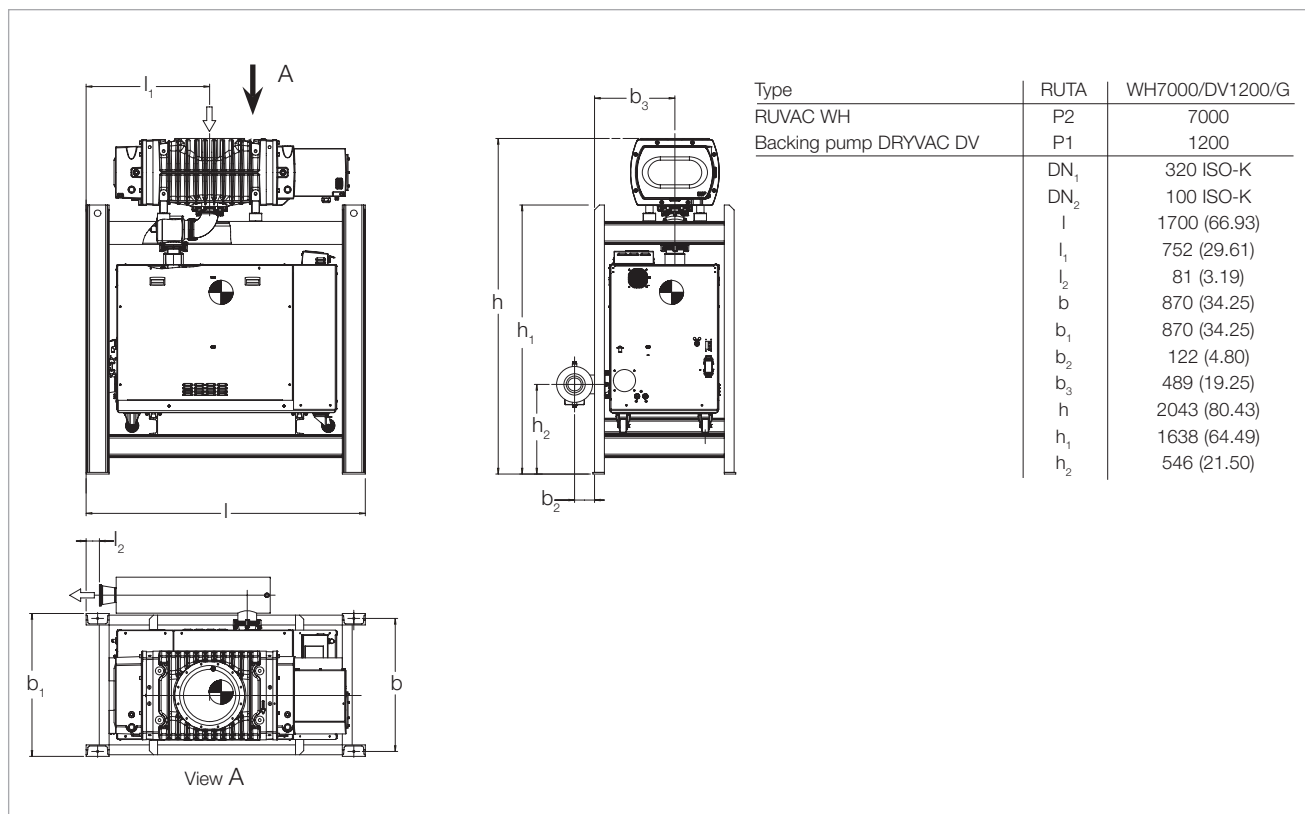

Dimensional drawing of the pump system with dry compressing DRYVAC DV 1200, frame version; dimensions in brackets () are in inch

Technical Data, 50 Hz

RUTA WH 7000/DV1200/G

RUVAC WH	P2	7000
Backing pump DRYVAC DV	P1	1200
Pumping speed, 50 Hz at 10^{-1} mbar (7.5×10^{-2} Torr)	m^3/h (cfm)	5537 (3259)
Ultimate total pressure without gas ballast	mbar (Torr)	$< 6.0 \times 10^{-4}$ (4.5×10^{-4})
Installed motor power 400 V, 50 Hz	kW (hp)	41.0 (55)
Electrical power consumption at 10^{-1} mbar (7.5×10^{-2} Torr)	kW (hp)	16.2 (21.7)
Noise level with silencer at 10^{-1} mbar (7.5×10^{-2} Torr)	dB(A)	< 68
Weight, total, approx.	kg (lbs)	2450 (5410)
Connecting flange		
Inlet port	DN ₁	320 ISO-K
Outlet port	DN ₂	100 ISO-K

Ordering Information

RUTA WH 7000/DV1200/G

		Part No.
RUVAC WH	P2	7000
Backing pump DRYVAC DV	P1	1200
Pump system, complete (adaptor version), frame mounted, with Roots vacuum pump RUVAC WH		503 172 V001 ¹⁾

¹⁾ Including external frequency converter

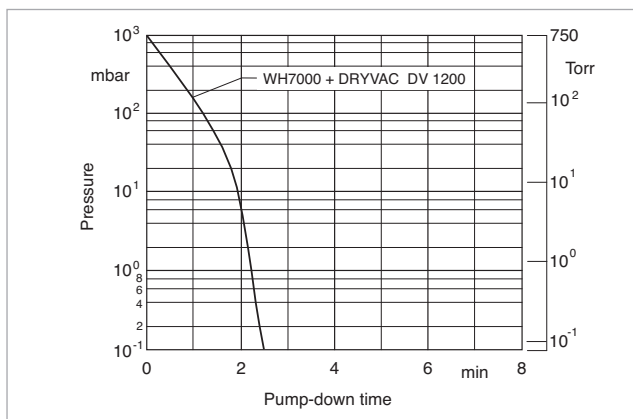

Pump-down time diagram for a 10 m³ tank at 50 Hz

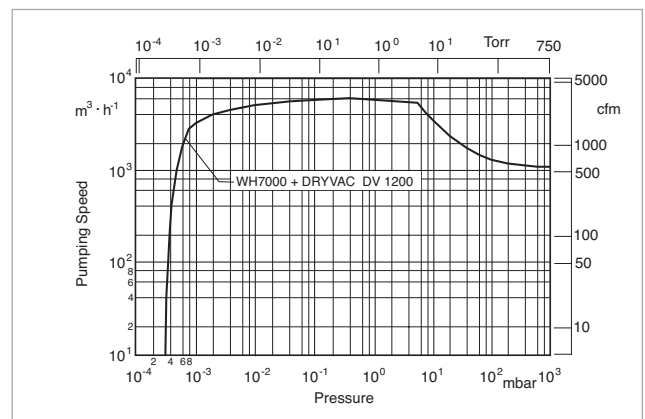

Pumping speed diagram at 50 Hz

DRYVAC Load Lock Pump Systems Adaptor Version

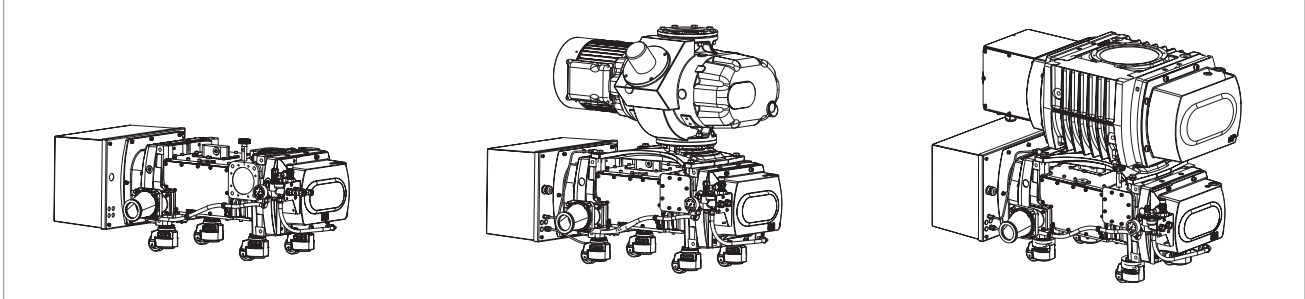

DRYVAC load lock pump system RUTA DV650S (left), RUTA WSU2001/DV650S/A (middle) and RUTA WHU4400/DV650S/A (right)

Standard Equipment

- DRYVAC DV S and RUVAC WHU with water cooling
- RUVAC WSU with air cooling
- Rollable pump system with locking foot
- Hermetically sealed
- Integrated protection functions (discharge pressure, temperatures and current consumption)
- Relay module (digital I/O)
- Non-return valve

- Leak detection port
- Lubricant: synthetic oil (LVO 400/410)

Options

- Exhaust silencer
- Bus interface
- Seal gas connection
- Gear chamber evacuation

- RUVAC WAU
- Frequency converter for RUVAC pump
- Electrical controller
- Oil drain valve
- Cooling water monitoring
- Quick couplings for water connections, blocking on both sides
- Frame

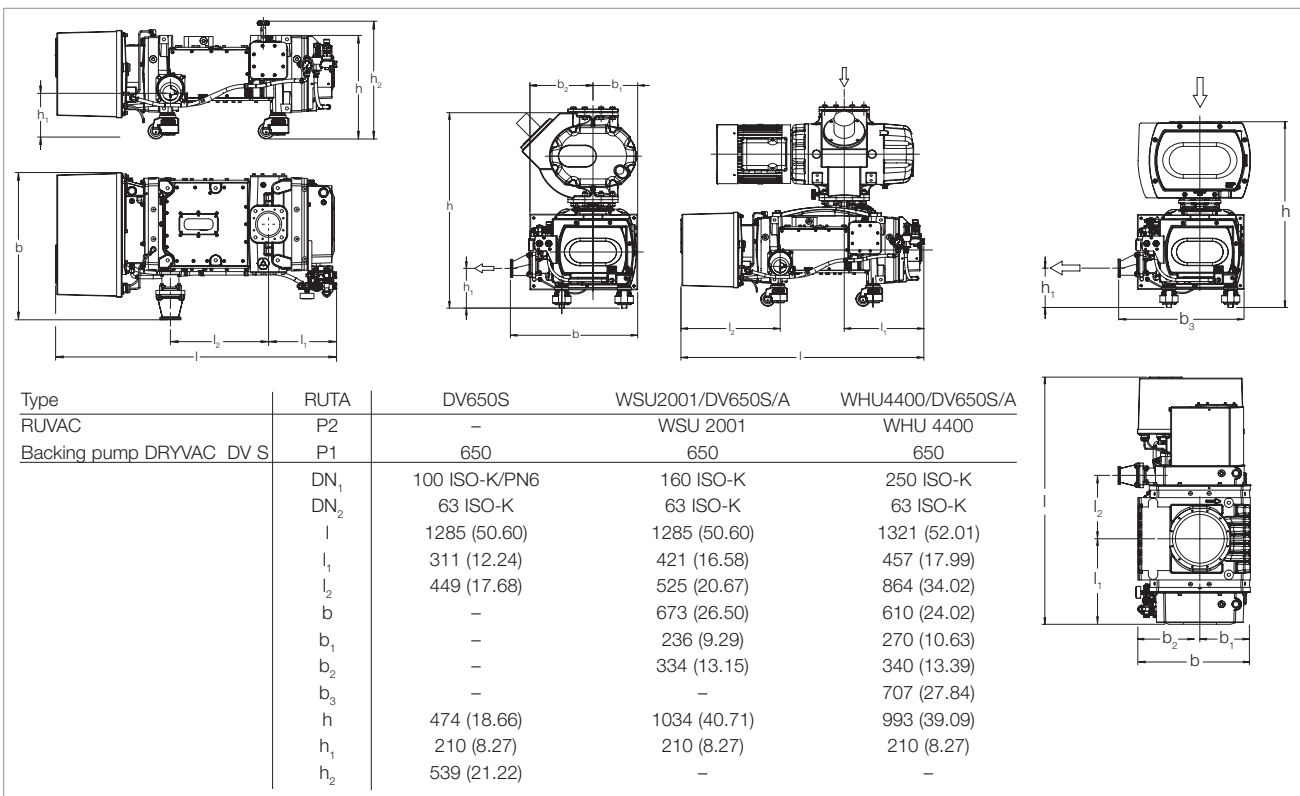

Dimensional drawing of the load lock pump systems with dry compressing DRYVAC backing pump, adaptor version: RUTA DV650S (left), RUTA WSU2001/DV650S/A (middle) and RUTA WHU4400/DV650S/A (right); dimensions in brackets () are in inch

Technical Data

RUTA

		DV650S	WSU2001/DV650S/A	WHU4400/DV650S/A
RUVAC WSU/WHU (WAU possible)	P2	–	WSU 2001	WHU 4400
Backing pump DRYVAC DV S on castors	P1	650	650	650
Pumping speed, 50 Hz at 10 ⁻¹ mbar (7.5 x 10 ⁻² Torr)	m ³ /h (cfm)	520 (306)	1760 (1036)	3400 (2000)
Ultimate total pressure without gas ballast	mbar (Torr)	< 5.0 x 10 ⁻³ (3.75 x 10 ⁻⁴)	< 5.0 x 10 ⁻³ (3.75 x 10 ⁻⁴)	< 5.0 x 10 ⁻³ (3.75 x 10 ⁻⁴)
Installed motor power, 3-ph. 380-480 V, 50/60 Hz	kW (hp)	15.0 (20.4)	–	–
400-460 V, 50/60 Hz	kW (hp)	–	22.5 (30.6)	33.5 (45.6)
Electrical power consumption at 10 ⁻¹ mbar (7.5 x 10 ⁻² Torr)	kW (hp)	6.9 (9.4)	8.4 (11.4)	9.3 (12.6)
Noise level with permanently attached exhaust line at ultimate total pressure	dB(A)	65	70	70
Operating agent	LVO	410	400 / 410	400 / 410
Total oil filling, approx.	l (imp qt)	1.2 (1.05)	4.2 (3.0 / 1.2) 3.65 (2.6 / 1.05)	5.95 (4.75 / 1.2) 5.25 (4.2 / 1.05)
Total weight, approx.	kg (lbs)	590 (1300)	1100 (2425)	1350 (2976)
Permissible ambient temperature	°C	+5 to +50	+12 to +40	+10 to +40
Connecting flange Inlet port top	1 x DN ₁	100 ISO-K	160 ISO-K	250 ISO-K
side	2 x DN ₁	PN6	–	–
Outlet port	DN ₂	63 ISO-K	63 ISO-K	63 ISO-K

Ordering Information

RUTA

		DV650S	WSU2001/DV650S/A	WHU4400/DV650S/A
RUVAC WSU/WHU	P2	–	WSU 2001	WHU 4400
Backing pump DRYVAC DV S on castors	P1	650	650	650
Load lock pump system, complete (adaptor version) with Roots vacuum pump RUVAC		503 261 V001	503 255 V001	503 256 V001

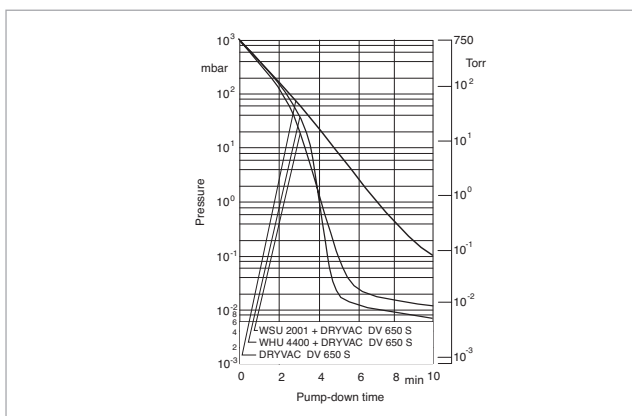

Pump-down time diagram for a 10 m³ tank at 50 Hz

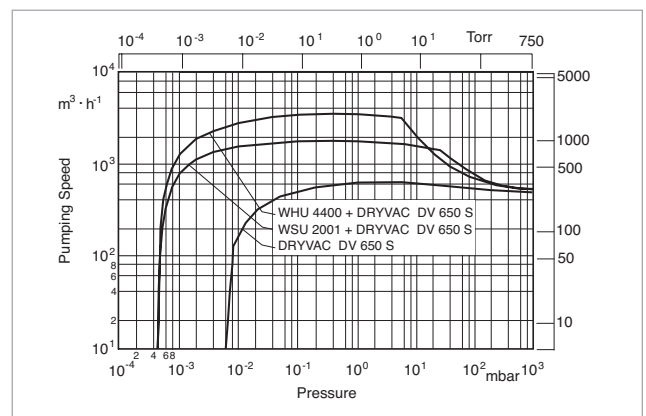

Pumping speed diagram at 50 Hz

DRYVAC Process Pump Systems Adaptor Version

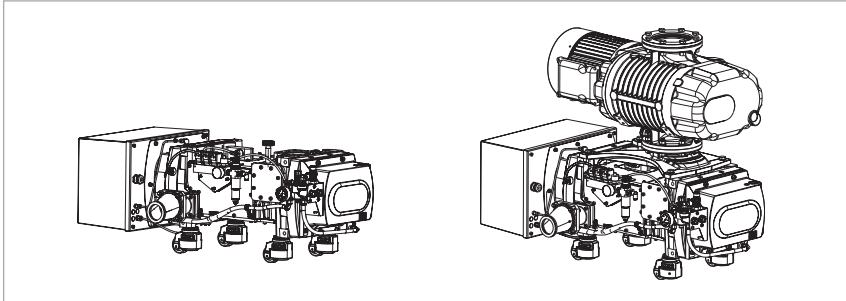

DRYVAC process pump system RUTA DV650C (left) and RUTA WS2001/DV650C/A (right)

Standard Equipment

- DRYVAC DV C with water cooling
- RUVAC WS with air cooling
- Rollable pump system with locking foot
- Hermetically sealed
- Seal gas module, threefold
- Integrated protection functions (discharge pressure, temperatures and current consumption)
- Relay module (digital I/O)
- Non-return valve
- Leak detection port
- Lubricant: synthetic oil (LVO 400/410)

Options

- Exhaust silencer
- Bus interface
- Gear chamber evacuation
- Electrical controller
- Oil drain valve
- Cooling water monitoring
- Quick couplings for water connections, blocking on both sides
- Frame

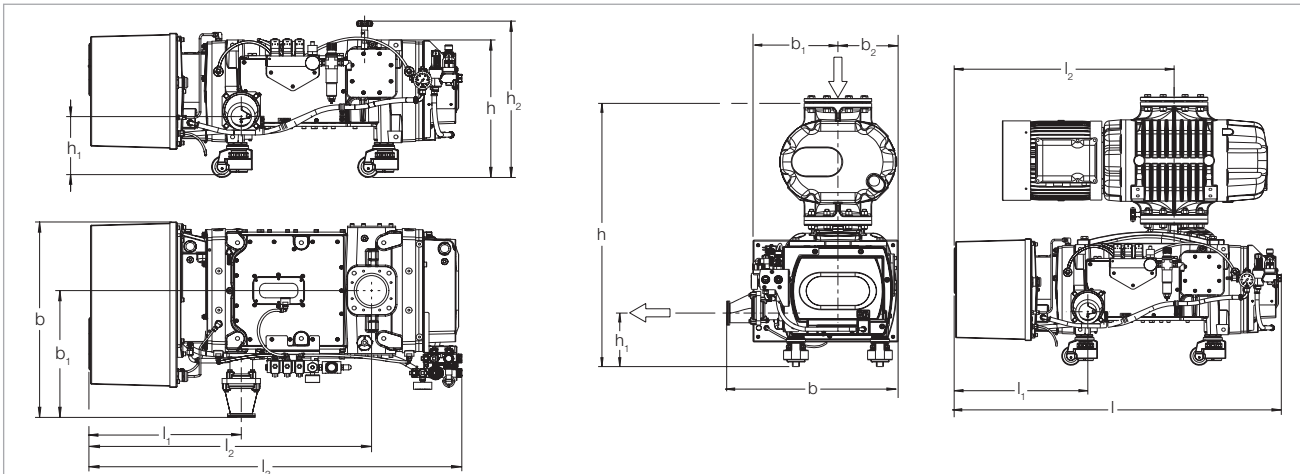

Type	RUTA	DV650C	WS2001/DV650C/A
RUVAC	P2	-	WS 2001
Backing pump DRYVAC DV C	P1	650	650
	DN ₁	100 ISO-K/PN6	160 ISO-K
	DN ₂	63 ISO-K	63 ISO-K
	l	1285 (50.60)	1285 (50.60)
	l ₁	525 (20.67)	864 (34.02)
	l ₂	974 (38.35)	525 (20.67)
	b	673 (26.50)	673 (26.50)
	b ₁	437 (17.21)	133 (5.24)
	b ₂	-	236 (9.29)
	h	474 (18.66)	1034 (40.71)
	h ₁	210 (8.27)	210 (8.27)
	h ₂	539 (21.22)	-

Dimensional drawing of the process pump systems with dry compressing DRYVAC backing pump, adaptor version: RUTA DV650C (left) and RUTA WS2001/DV650C/A (right); dimensions in brackets () are in inch

Technical Data

RUTA

DV650C

WS2001/DV650C/A

RUVAC WS	P2	–	2001
Backing pump DRYVAC DV C on castors	P1	650	650
Pumping speed, 50 Hz at 10^{-1} mbar (7.5×10^{-2} Torr)	m^3/h (cfm)	520 (306)	1760 (1036)
Ultimate total pressure without gas ballast	mbar (Torr)	$< 5 \times 10^{-3}$ (3.75×10^{-3})	$< 5 \times 10^{-4}$ (3.75×10^{-4})
Installed motor power, 3-ph. 380-480 V, 50/60 Hz	kW (hp)	15.0 (20.4)	–
400-460 V, 50/60 Hz	kW (hp)	–	22.5 (30.6)
Electrical power consumption at 10^{-1} mbar (7.5×10^{-2} Torr)	kW (hp)	6.9 (9.4)	8.4 (11.4)
Noise level with permanently attached exhaust line at ultimate total pressure	dB(A)	65	70
Operating agent	LVO	410	400/410
Total oil filling, approx.	l (imp qt)	1.2 (1.05)	4.2 (3.0 / 1.2) 3.65 (2.6 / 1.05)
Total weight, approx.	kg (lbs)	590 (1300)	1100 (2425)
Permissible ambient temperature	$^{\circ}\text{C}$	+5 to +50	+12 to +40
Connecting flange			
Inlet port			
top	1 x DN ₁	100 ISO-K	160 ISO-K
side	2 x DN ₁	PN6	–
Outlet port	DN ₂	63 ISO-K	63 ISO-K

Ordering Information

RUTA

DV650C

WS2001/DV650C/A

		Part No.	Part No.
RUVAC WS	P2	–	2001
Backing pump DRYVAC DV C on castors	P1	650	650
Process pump system, complete (adaptor version) with Roots vacuum pump RUVAC		503 262 V001	503 263 V001

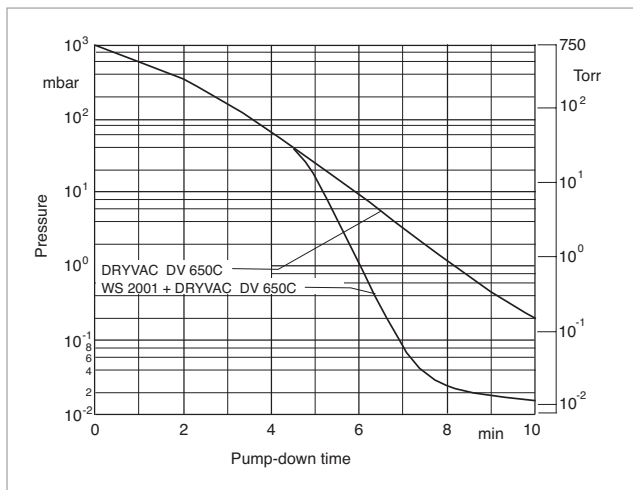

Pump-down time diagram for a 10 m³ tank at 50 Hz

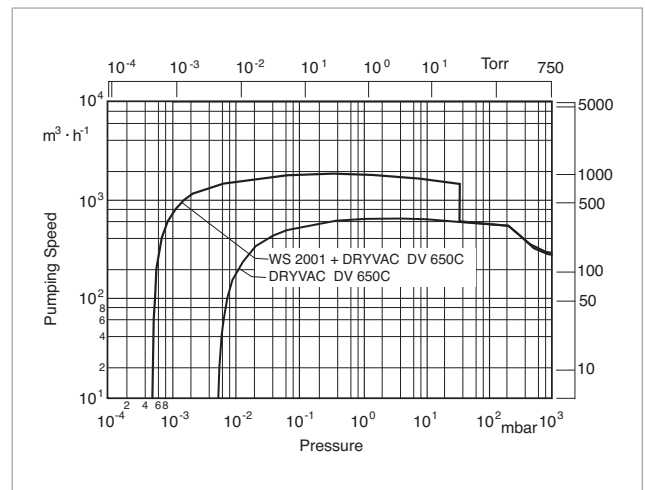

Pumping speed diagram at 50 Hz

DRYVAC Process Pump Systems with RUVAC WH Backing Pump Adaptor Version

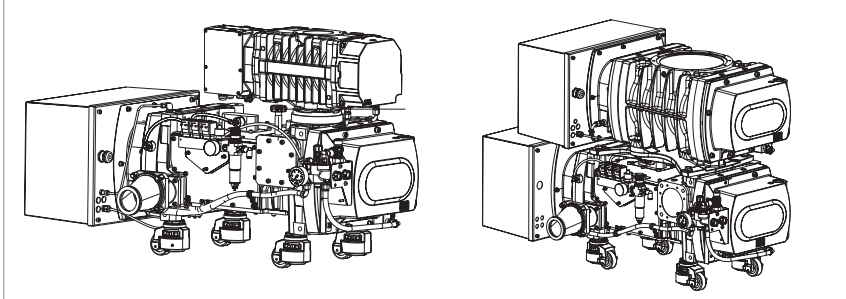

DRYVAC process pump system RUTA WH700FU/DV650C/A (left) and RUTA WH2500/DV650C/A (right)

Standard Equipment

- DRYVAC DV C and RUVAC WH with water cooling
- Rollable pump system with locking foot
- Hermetically sealed
- Seal gas module, threefold
- Integrated protection functions (discharge pressure, temperatures and current consumption)
- Relay module (digital I/O)
- Non-return valve
- Leak detection port
- Lubricant: synthetic oil (LVO 400/410)

Options

- Exhaust silencer
- Bus interface
- Gear chamber evacuation
- Electrical controller
- Oil drain valve
- Cooling water monitoring
- Quick couplings for water connections, blocking on both sides
- Frame

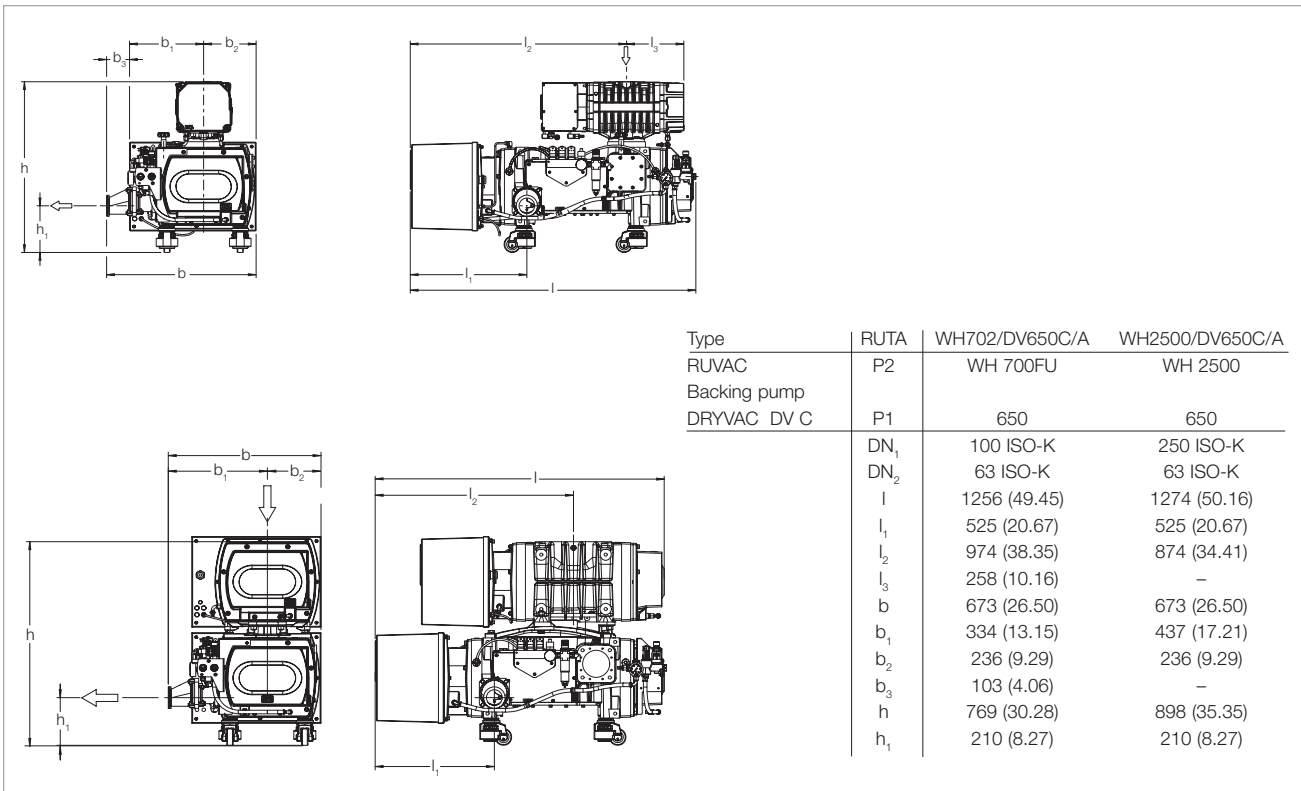

Dimensional drawing of the process pump systems with dry compressing DRYVAC backing pump, adaptor version: RUTA WH700FU/DV650C/A (top) and RUTA WH2500/DV650C/A (below); dimensions in brackets () are in inch

Technical Data

RUTA WH

700FU/DV650C/A

2500/DV650C/A

RUVAC WH	P2	700FU	2500
Backing pump DRYVAC DV C on castors	P1	650	650
Pumping speed, 50 Hz at 10 ⁻¹ mbar (7.5 x 10 ⁻² Torr)	m ³ /h (cfm)	1220 (718)	3115 (1834)
Ultimate total pressure without gas ballast	mbar (Torr)	< 6 x 10 ⁻⁴ (4.5 x 10 ⁻⁴)	< 5 x 10 ⁻⁴ (3.75 x 10 ⁻⁴)
Installed motor power, 3-ph. 380-480 V, 50/60 Hz	kW (hp)	17.2 (23.4)	–
400-460 V, 50/60 Hz	kW (hp)	–	21.2 (28.8)
Electrical power consumption at 10 ⁻¹ mbar (7.5 x 10 ⁻² Torr)	kW (hp)	7.4 (10.1)	8.6 (11.7)
Noise level with permanently attached exhaust line at ultimate total pressure	dB(A)	70	70
Operating agent	LVO	400/410	410
Total oil filling, approx.	l (imp qt)	2.1 (0.9 / 1.2) 1.9 (0.8 / 1.1)	2.4 (1.2 / 1.2) 2.1 (1.05 / 1.05)
Total weight, approx.	kg (lbs)	800 (1764)	1100 (2425)
Permissible ambient temperature	°C	+12 to +50	+10 to +50
Connecting flange Inlet port			
top	1 x DN ₁	100 ISO-K	250 ISO-K
side	2 x DN ₁	–	–
Outlet port	DN ₂	63 ISO-K	63 ISO-K

Ordering Information

RUTA WH

700FU/DV650C/A

2500/DV650C/A

		Part No.	Part No.
RUVAC WH	P2	700FU	2500
Backing pump DRYVAC DV C on castors	P1	650	650
Process pump system, complete (adaptor version) with Roots vacuum pump RUVAC		503 257 V001	503 258 V001

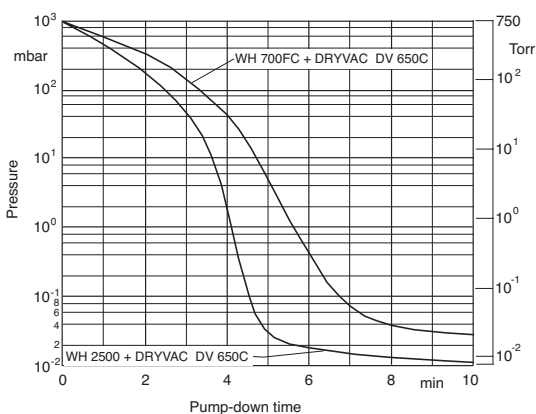

Pump-down time diagram for a 10 m³ tank at 50 Hz

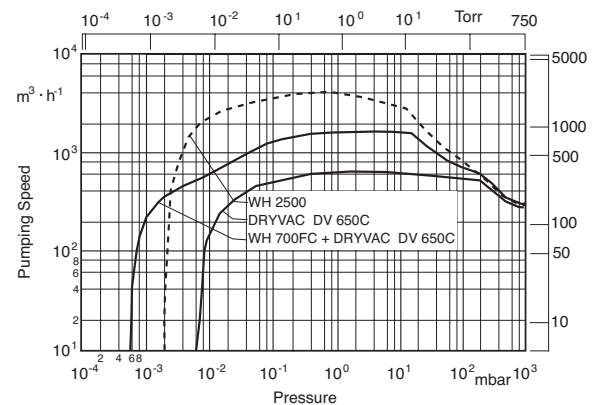

Pumping speed diagram at 50 Hz

DRYVAC Pump Systems, enclosed Adaptor Version

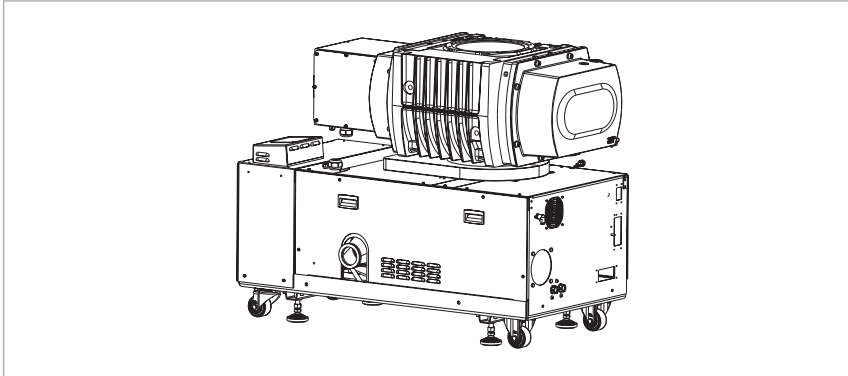

RUTA WHU4400/DV650S-i/A/E

Standard Equipment

- DRYVAC DV S and RUVAC WHU with water cooling
- Pump system partly enclosed and electrically prewired
- With integrated PLC (Part No. 503259V001)
- Pumps independently electrically controllable (Part No. 503260V001)
- Hermetically sealed
- Integrated protection functions (discharge pressure, temperatures and current consumption)

- Relay module (digital I/O)
- Non-return valve
- Leak detection port
- Lubricant: synthetic oil (LVO 400/410)

Options

- RUVAC WS / WSU / WH
- Exhaust silencer
- Bus interface

- Seal gas connection
- Gear chamber evacuation
- Frequency converter for RUVAC pump
- Oil drain valve
- Cooling water monitoring
- Quick couplings for water connections, blocking on both sides
- Housing suction facility

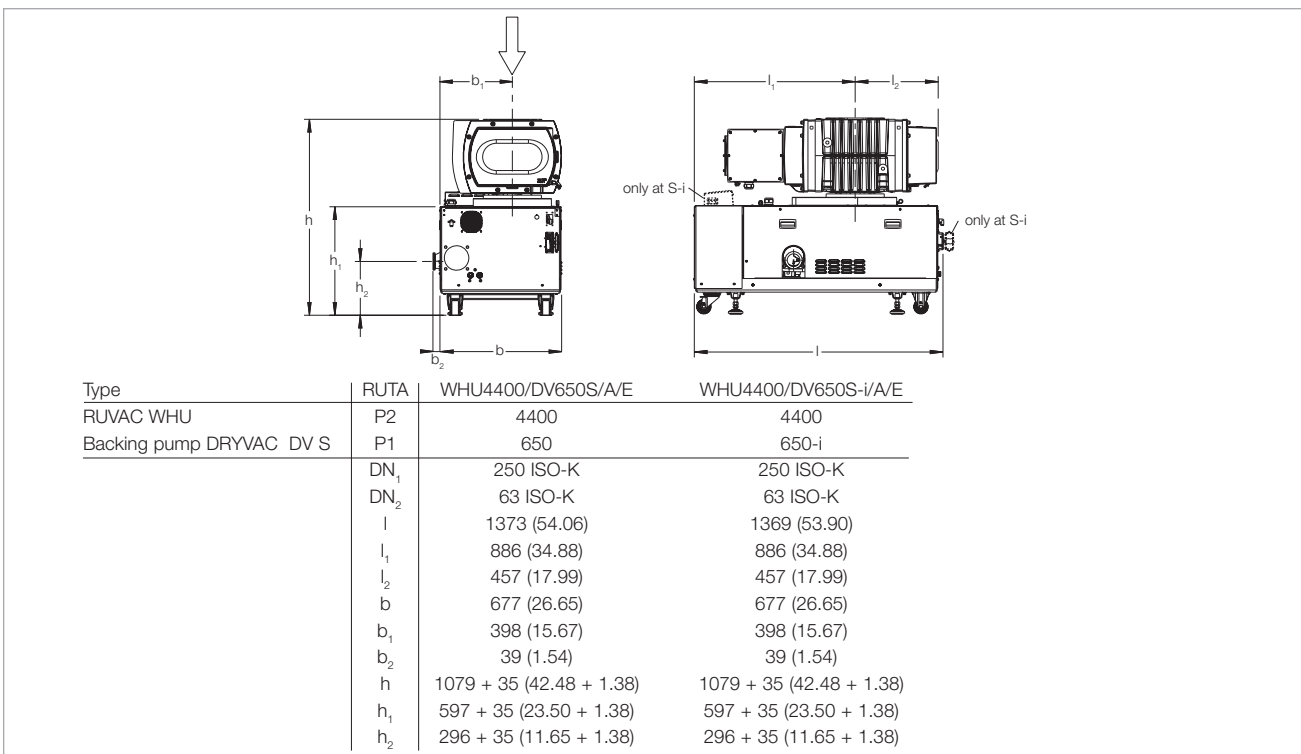

Dimensional drawing of the enclosed pump systems with DRYVAC DV650S(-i) backing pumps; dimensions in brackets () are in inch

Technical Data

RUTA WHU

4400/DV650S/A/E

4400/DV650S-i/A/E

RUVAC WHU (WH possible)	P2	4400	4400
Backing pump DRYVAC DV S with enclosure, silencer, castors and additional PLC	P1 P1	650 -	- 650-i
Pumping speed, 50 Hz at 1×10^{-1} mbar (7.5×10^{-2} Torr)	m^3/h (cfm)	3400 (2000)	3400 (2000)
Ultimate total pressure without gas ballast	mbar (Torr)	$< 5.0 \times 10^{-3}$ (3.75×10^{-3})	$< 5.0 \times 10^{-3}$ (3.75×10^{-3})
Installed motor power, 3-ph. 400 – 460 V, 50/60 Hz	kW (hp)	33.5 (45.6)	33.5 (45.6)
Electrical power consumption at 1×10^{-1} mbar (7.5×10^{-2} Torr)	kW (hp)	9.3 (12.6)	9.3 (12.6)
Noise level with permanently attached exhaust line at ultimate total pressure	dB(A)	70	70
Operating agent	LVO	400/410	400/410
Total oil filling, approx.	l (imp qt)	5.95 (4.75 / 1.2) 5.25 (4.2 / 1.05)	5.95 (4.75 / 1.2) 5.25 (4.2 / 1.05)
Total weight, approx.	kg (lbs)	1350 (2976)	1350 (2976)
Permissible ambient temperature	°C	+10 to +40	+10 to +40
Connecting flange Inlet port Outlet port	DN ₁ DN ₂	250 ISO-K 63 ISO-K	250 ISO-K 63 ISO-K

Ordering Information

RUTA WHU

4400/DV650S/A/E

4400/DV650S-i/A/E

		Part No.	Part No.
RUVAC WHU (WH possible)	P2	4400	4400
Backing pump DRYVAC DV S	P1	650	650-i
Enclosed pump system, complete (adaptor version) with Roots vacuum pump RUVAC		503 260 V001	503 259 V001

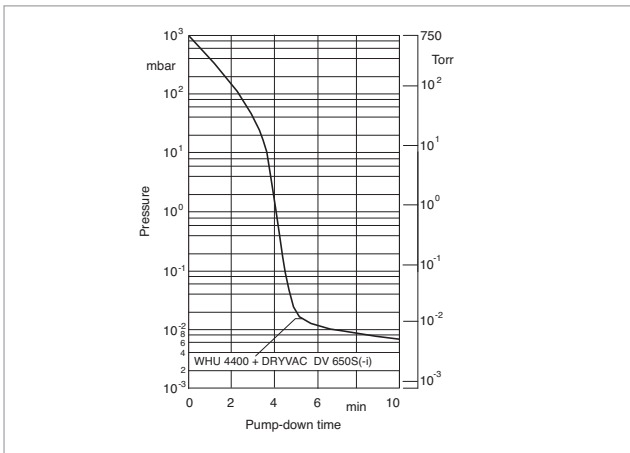

Pump-down time diagram for a 10 m³ tank at 50 Hz

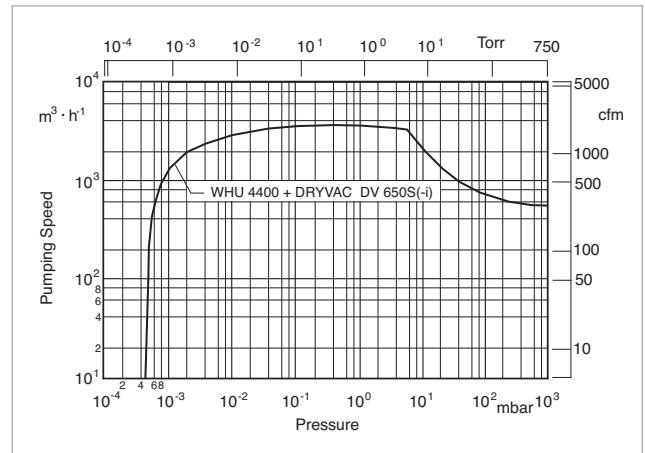

Pumping speed diagram at 50 Hz

Dry Compressing Pump Systems DRYVAC



DRYVAC SYSTEM: Basic System Configuration (left), Smart System Configuration (middle), PowerBoost (right)

Leybold has refined its Dryvac vacuum pump systems, making them adaptable for a variety of applications — The recipe is simple and efficient: Take a dry compressing screw vacuum pump and a roots pump, combine both of the proven technologies along with pressure measurement, shut-off devices and electrical control, creating a turn-key smart vacuum system that is cost-effective and completely ready for use by the customer.

For more than five years, the fore vacuum systems of the Dryvac pump series by Leybold are already being used successfully in various processes, which can be simple or very challenging. The pumping systems are known for their maximum suction capacity while operating at minimum operating costs.

Now, Leybold has developed the systems further: The new two-stage Dryvac systems distinguish themselves

particularly by their modular design and the resulting improved user friendliness and easy servicing. All equipment features are aligned to the requirements of the different markets.

Advantage for the User

- Extremely compact design provides more space in production areas
- Very low noise level improves working environment conditions
- Significant cost reduction because of high energy efficiency
- Clean technology with no oil emissions
- Optimized for fast cycle / load lock applications
- Fastest pump down times – by high throughput pump mechanisms
- Highest pumping speed for dry and booster pumps
- Pumping speed from 2,000 m³/h up to 9,800 m³/h

- Integrated smart monitoring of major parameters
- Standard Digital I/O interface and Profibus (optional) for the whole product family
- Platform based product design proven in a huge installed base
- Tolerance to misuse
- Optimized design and screw profile
- Lowest power consumption
- Low cost of ownership
- minimized foot print

Typical Applications

- Glas Coating
- Crystal Pulling
- Sputtering / Decorative Layers
- Furnaces
- Protective Coating
- Battery
- Solar
- Display

Basic System Configuration

Pre-assembled vacuum pump systems (basic version). Monitoring, control, programming, and power electronic components to be provided by the customer.

Standard Configuration:

- exhaust to the side
- triple purge gas module

Optional Configurations:

Double purge gas module, gas ballast system, non-return valve, quick-access couplings (water), mating connector for power & signal supply, relay board (digital I/O)

Advantages

- high performance with excellent cost-performance ratio
- worldwide service & spare parts availability
- rapid response times

Smart System Configuration

The smart pump system versions are characterized by integrated power electronics, monitoring devices for the purge gas system and key parameters, easy and user-friendly operation handling (local / remote), and additional features, e.g. connecting a gauge head.

Standard Configuration:

- digital I/O interface
- prepared for connecting a variety of different gauge heads (CTR, DU, TTR)
- Emergency Stop (EMS)
- compensation for voltage drops ($\leq 2s$)
- triple purge gas module
- exhaust to the side

Optional Configurations:

Double purge gas module, gas ballast system, non-return valve, quick-action couplings, Profibus, Ethernet or Profinet interfaces!

Advantages

- high performance at attractive prices
- autonomous vacuum pump system
- worldwide service & spare parts availability
- rapid response times

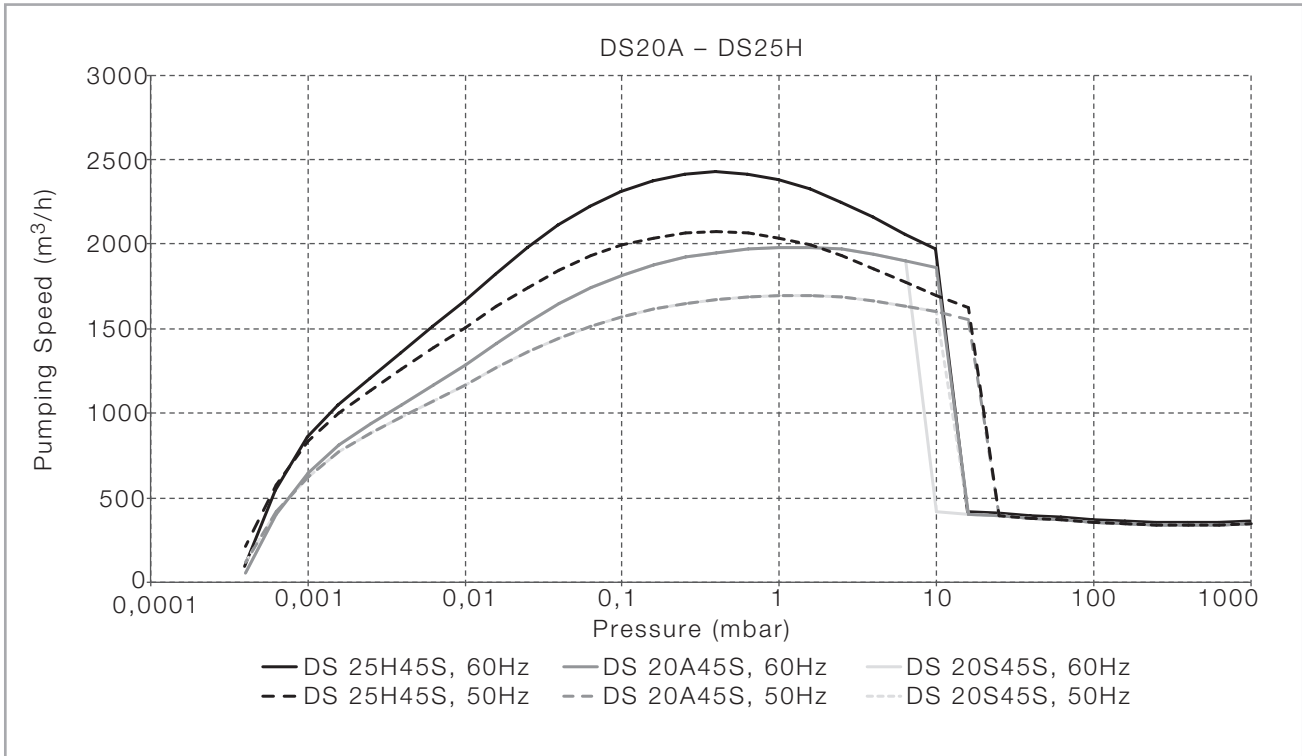

Saugvermögenskurven mit DV 450 (ohne Umwegleitung)

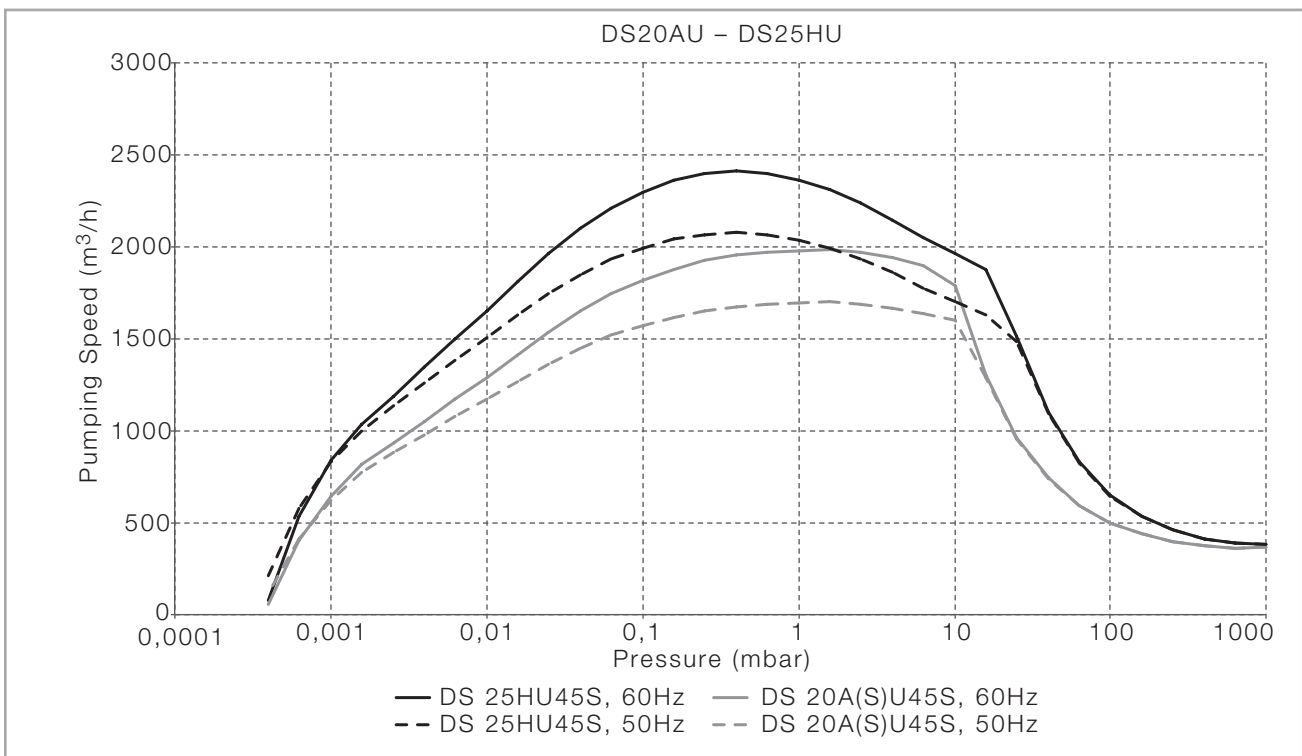

Saugvermögenskurven mit DV 450 (mit Umwegleitung)

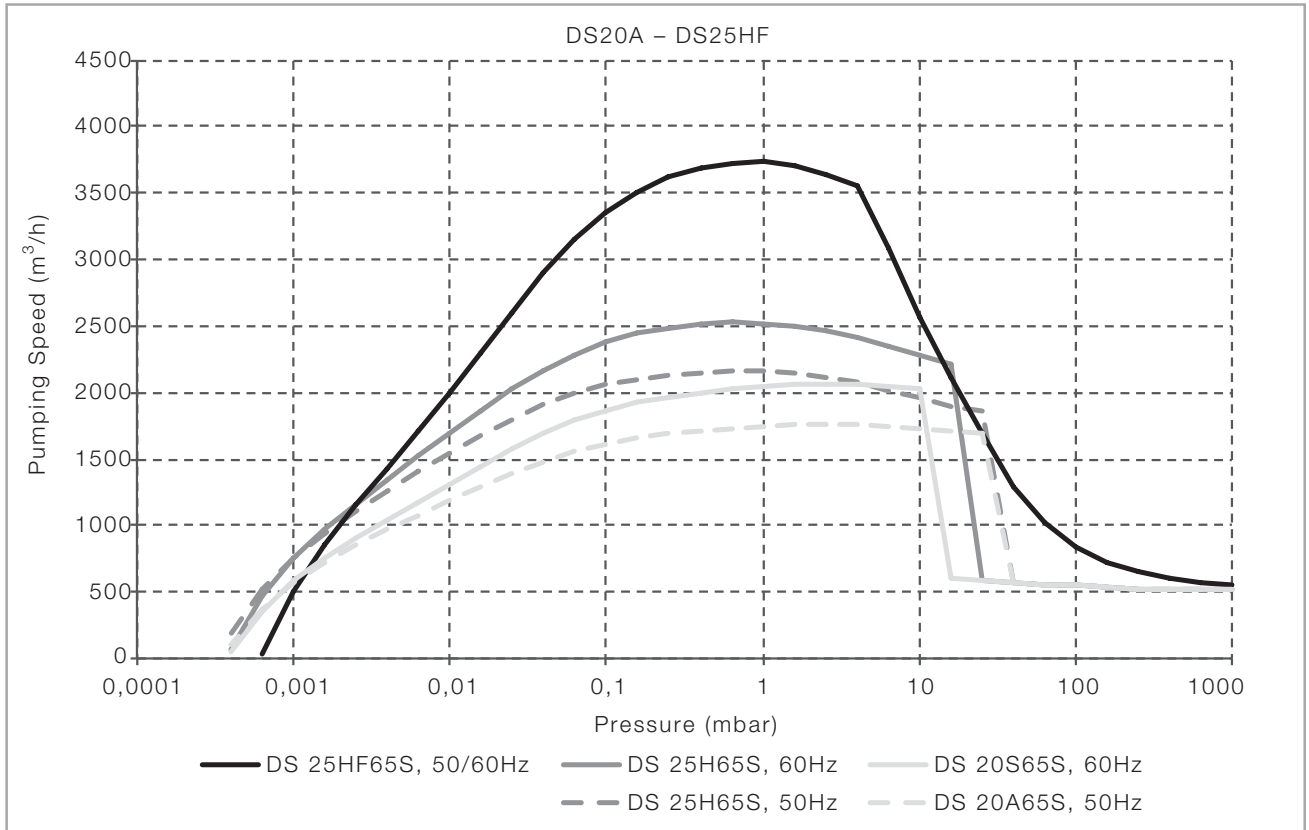

Saugvermögenskurven mit DV 650 (ohne Umwegleitung)

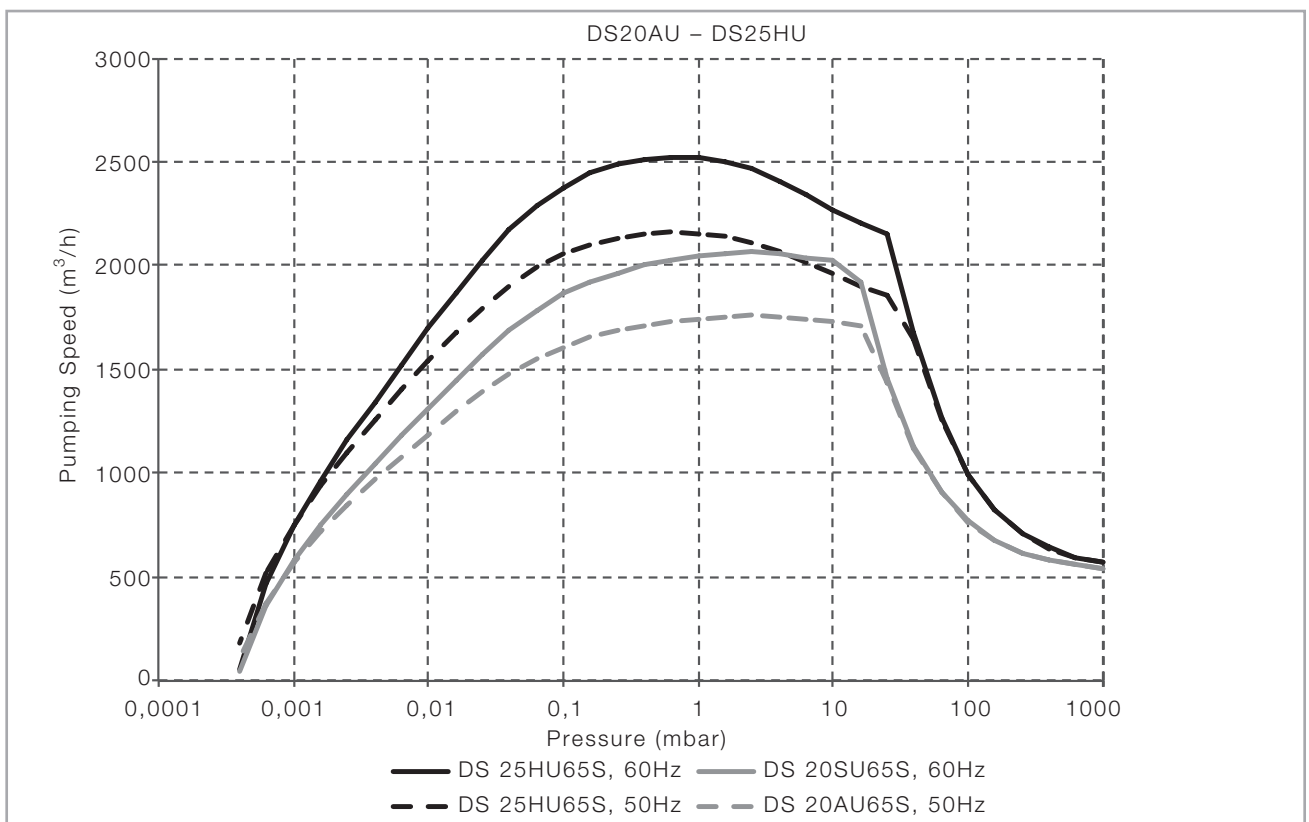

Saugvermögenskurven mit DV 650 (mit Umwegleitung)

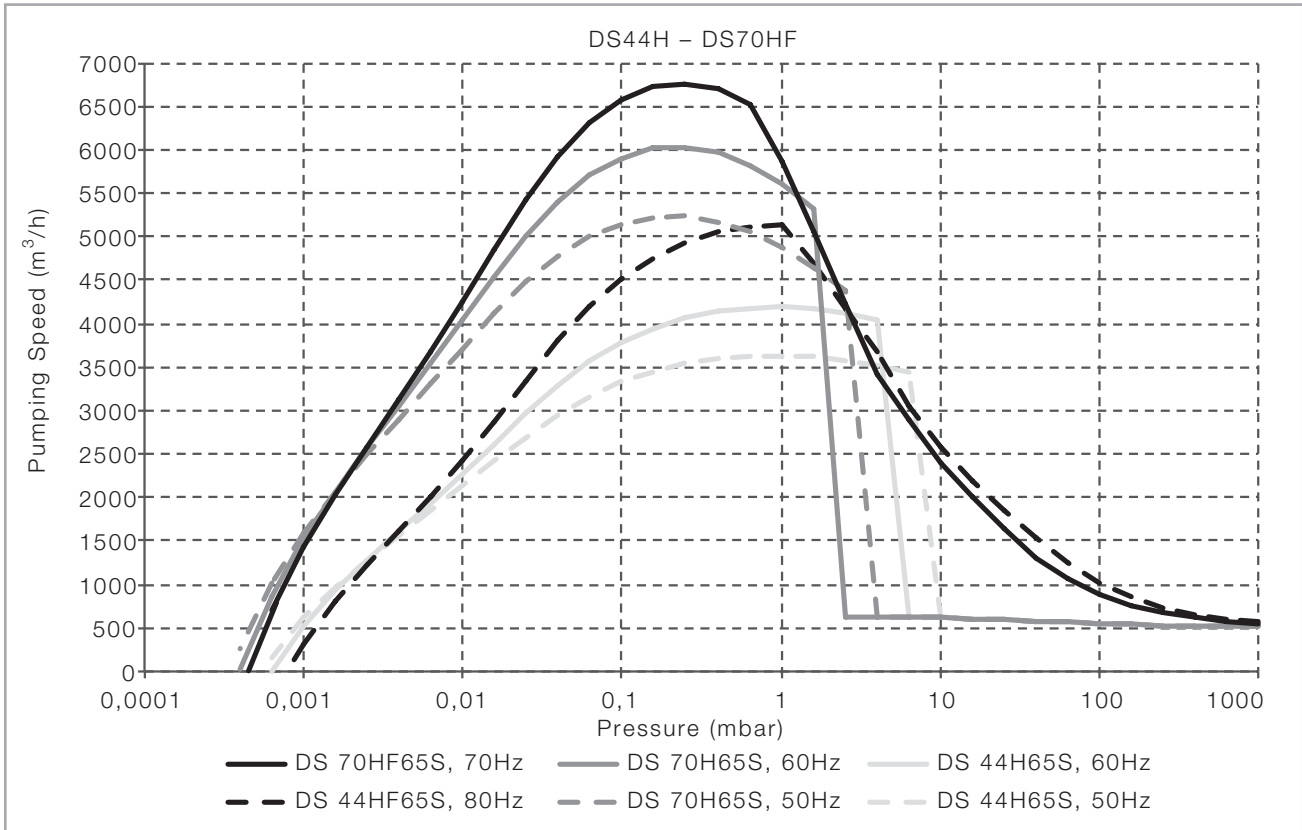

Saugvermögenskurven mit DV 650 (ohne Umwegleitung)

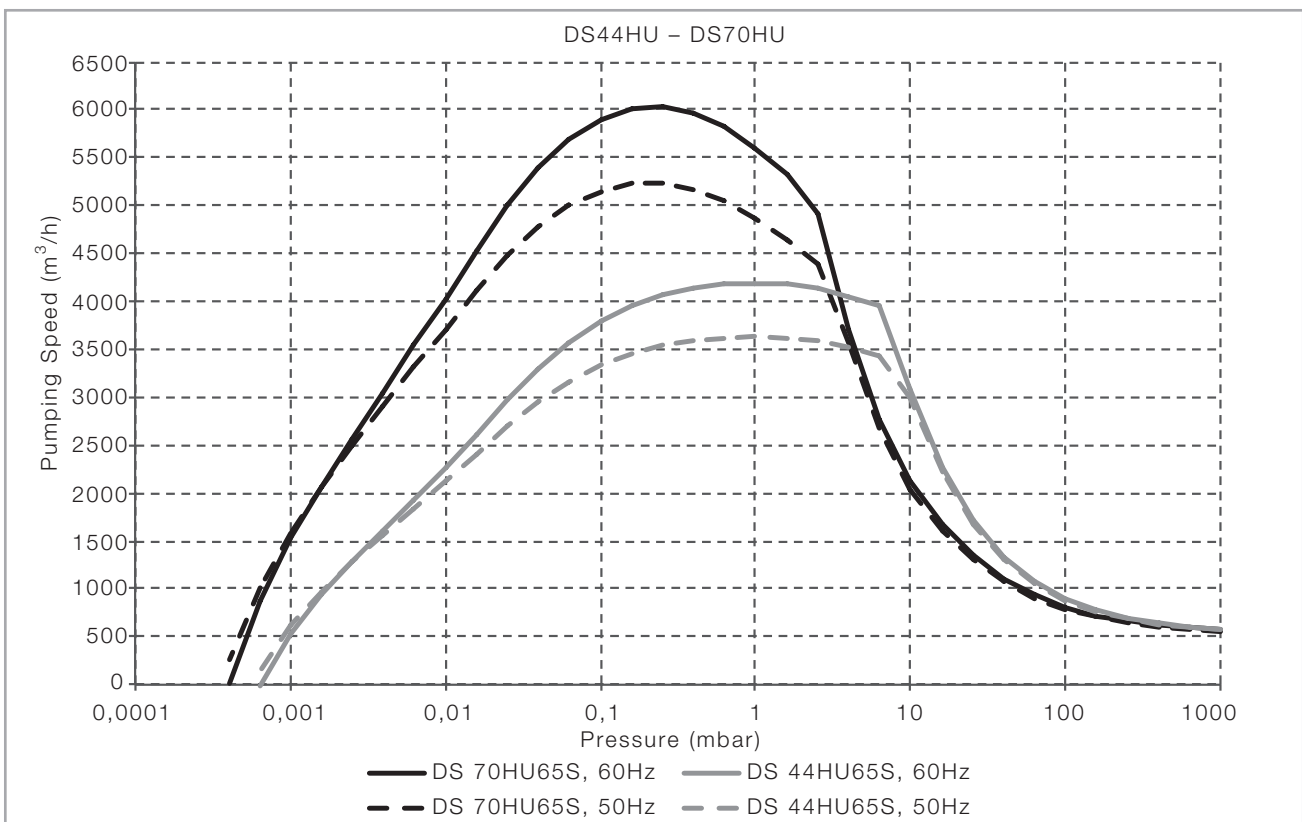

Saugvermögenskurven mit DV 650 (mit Umwegleitung)

Dry Compressing Pump Systems DRYVAC Basic System Configuration



The two-stage DRYVAC SYSTEMS consist of a combination of dry compressing Roots pumps and screw pumps. The Roots pump installed on top of the backing pump serves as a booster for increasing the pumping speed.

Various types of pumps may be used with DRYVAC SYSTEMS:

Roots Pumps

RUVAC WA
RUVAC WAU
RUVAC WH
RUVAC WHU
RUVAC WS
RUVAC WSU

Backing Pumps

DRYVAC DV S
DRYVAC DV C

All DRYVAC SYSTEMS (b versions) described hereinafter are delivered as basic versions. The basic version can be customized according to individual requirements with accessories (e.g. Harting plug or gas ballast system).

The pumps are water-cooled and lubricated either with synthetic oil or PFPE.

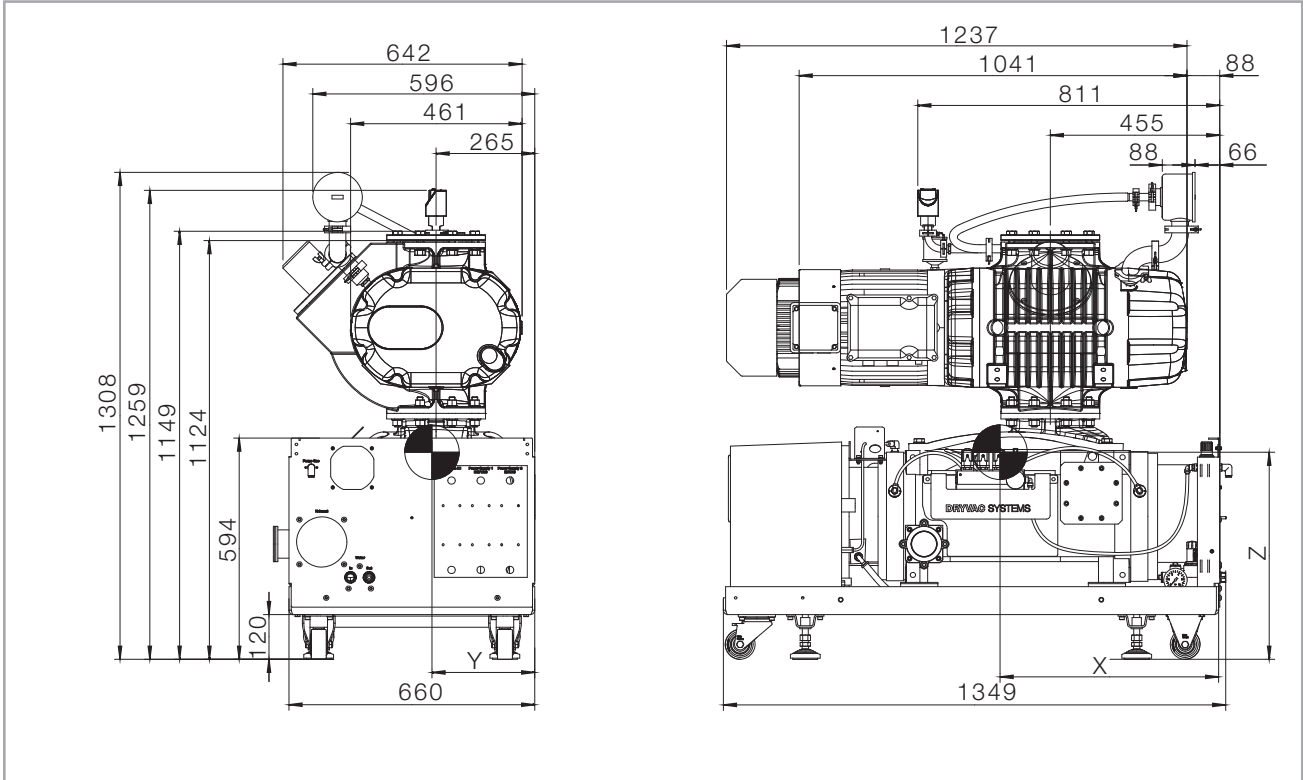

Dimensional drawing for DS 20A(U) 45(S/C) b, DS 20A(U) 65(S/C) b, DS 20S(U) 45(S/C) b, DS 20S(U) 65(S/C) b (Dimensions in mm)

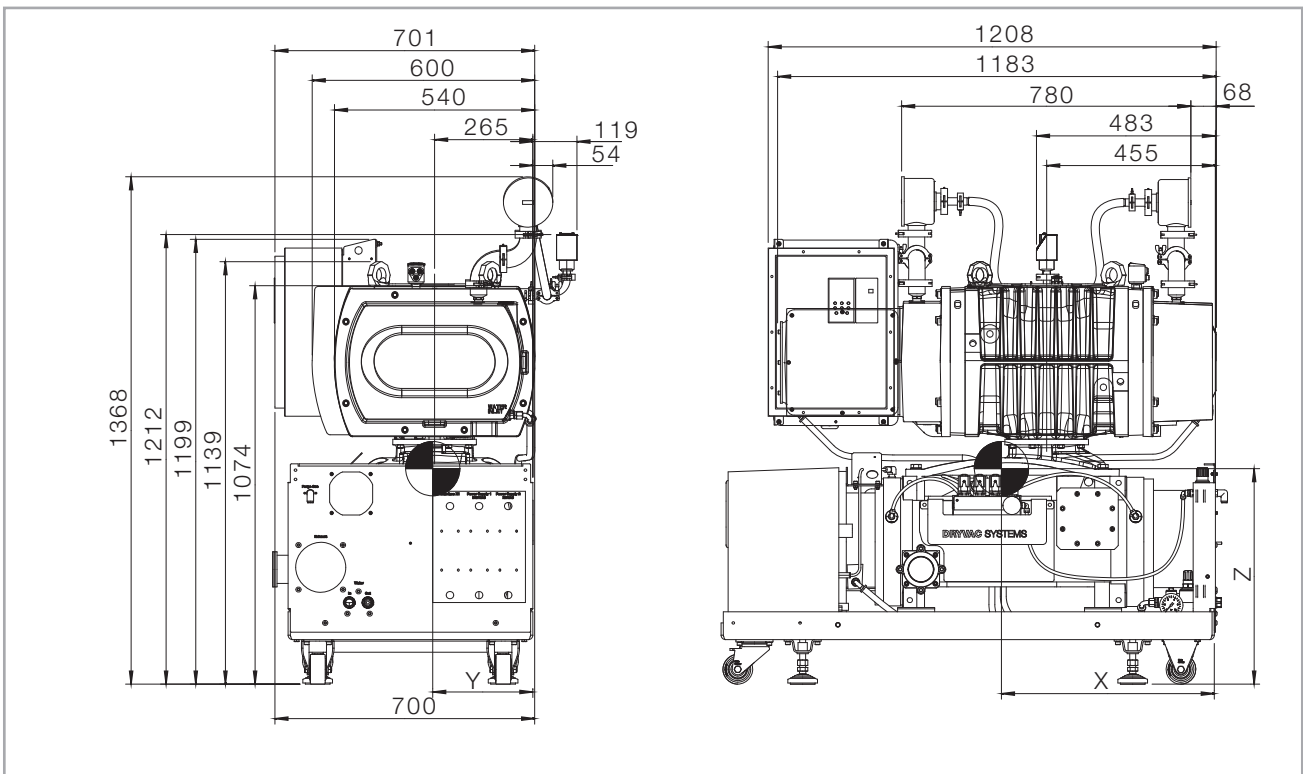

Dimensional drawing for DS 25H(U) 45(S/C) b, DS25H(U) 65(S/C) b, DS 25HF 45(S/C) b, DS 25HF 65(S/C) b (Dimensions in mm)

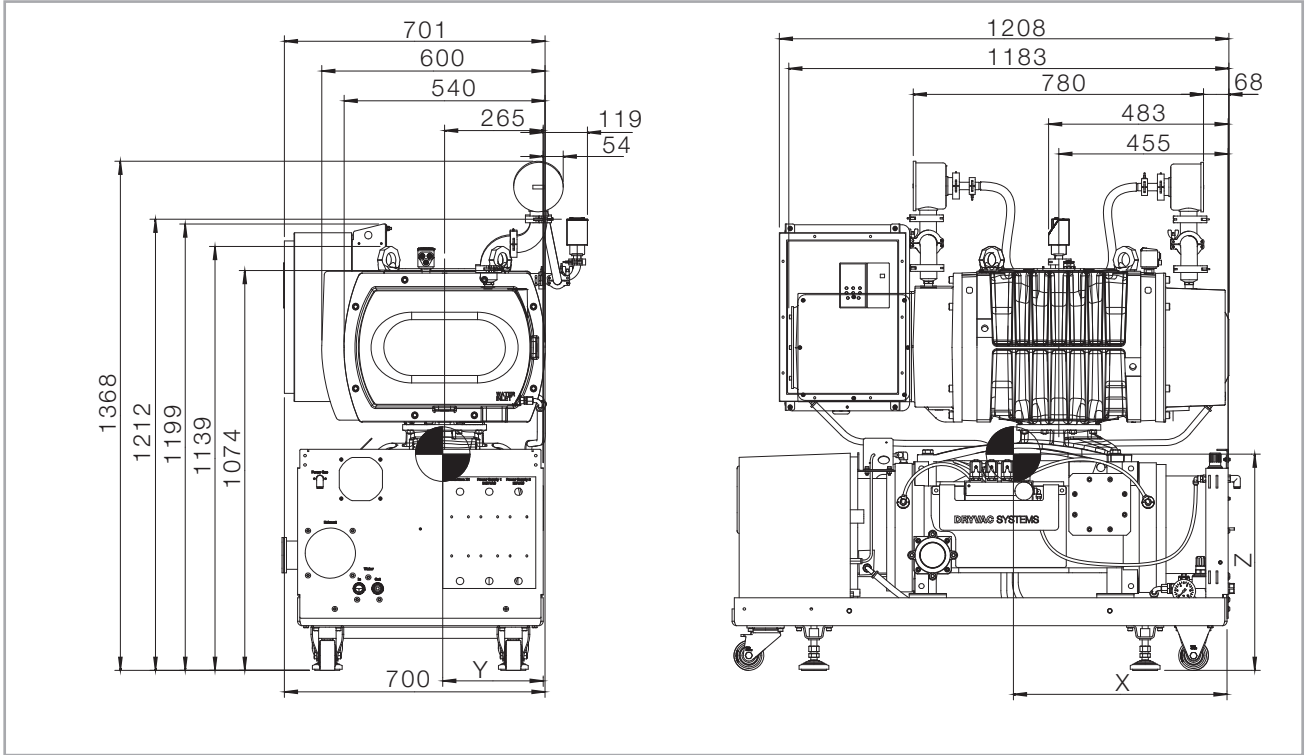

Dimensional drawing for DS 44H(U) 45(S/C) b, DS 44H(U) 65(S/C) b, DS 44HF 65(S/C) b (Dimensions in mm)

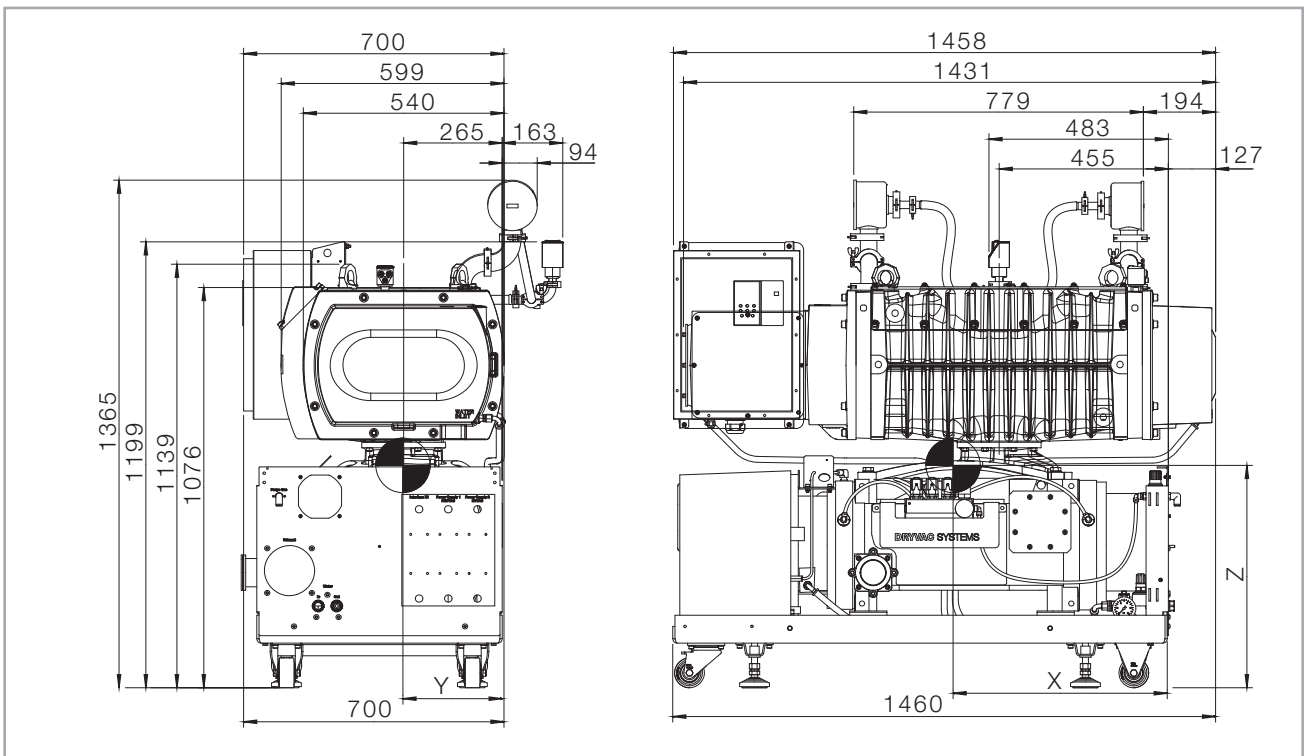

Dimensional drawing for DS 70H(U) 65(S/C) b, DS 70HF 65(S/C) b (Dimensions in mm)

Technical Data

DRYVAC SYSTEMS DS

	20A(U) 45(S/C) b(T)	20S(U) 45(S/C) b(T)	20A(U) 65(S/C) b(T)	20S(U) 65(S/C) b(T)
Max. pump speed w/o gas ballast (50/60 Hz) (± 5 %)	2000 / 2400 m ³ /h			
Max. effective pumping speed (50/60 Hz) (± 5 %)	1600 / 1850 m ³ /h		1750 / 2050 m ³ /h	
Ult. total pressure w/o rotor and inlet purge (± 10 %)	≤ 5 x 10 ⁻³ mbar			
Maximum permissible inlet pressure	1013 mbar			
Maximum permissible discharge pressure (relative to ambient)	+200 mbar			
Integral leak rate	<5 x 10 ⁻⁴ mbar x l/s	<1 x 10 ⁻⁴ mbar x l/s	<5 x 10 ⁻⁴ mbar x l/s	<1 x 10 ⁻⁴ mbar x l/s
Water vapour tolerance with purge gas (SV40)	60 mbar ≥ 20 NI/min			
Water vapour capacity	15 kg/h		25 kg/h	
Permissible ambient temperature	+5 ... + 35 °C			
Storage temperature	-10 ... + 60 °C			
Noise level (rigid exhaust pipe) ⁶⁾	65 dB(A) (K _{pA} = 3dB)			
Screw				
Roots	< 80 dB(A)	< 72 dB(A)	< 80 dB(A)	< 72 dB(A)
Relative atmospheric humidity	95 %, non-condensing			
Installation location	up to 2000 m (NHN) ²⁾			
Cooling	Water / air			
Mains voltages and frequencies	380 – 440V 50Hz / 420 – 480V 60Hz			
Frequency (± 5 %)	50 / 60 Hz			
Phases	3-ph			
Rated power (400 V 50 Hz / 460 V 60 Hz) (± 0,8 kW)				
Screw	11 kW	11 kW	15 kW	15 kW
Roots	7.5 kW	7.5 / 8.5 kW	7.5 kW	7.5 / 8.5 kW
Roots with 18.5 kW (U) totalling	18.5 kW	18.5 / 19.5 kW	22.5 kW	22.5 / 23.5 kW
totalling with 18.5 kW (U)				
Rated current (400 V 50 Hz / 460 V 60 Hz)				
Screw	24 / 21 A	24 / 21 A	31 / 27 A	31 / 27 A
Roots	13.6 / 12 A	15 A	13.6 / 12 A	15 A
Roots with 18.5 kW (U) totalling	37.6 / 33 A	39 / 36 A	44.6 / 39 A	46 / 42 A
totalling with 18.5 kW (U)				
Power consumption at ultimate pressure (50/60 Hz)				
Motor efficiency class, calculated and configured acc. to EN 60034-30	IE2			
Electrical power rating (400 V 50 Hz / 460 V 60 Hz)				
Screw	17 / 14.9 kVA	17 / 14.9 kVA	21.8 / 19.1 kVA	21.8 / 19.1 kVA
Roots	9.8 / 8.7 kVA	10.7 kVA	9.8 / 8.7 kVA	10.7 kVA
Roots with 18.5 kW (U) totalling	26.8 / 23.6 kVA	27.7 / 25.6 kVA	31.6 / 27.8 kVA	32.5 / 29.8 kVA
totalling with 18.5 kW (U)				
Speed Screw / Roots (50 Hz)	7200 / 3000 rpm			
Screw / Roots (60 Hz)	7200 / 3600 rpm			
Min. permissible speed Screw ³⁾	1200 rpm			
Min. permissible speed Roots (off) ⁴⁾	off			
Protection class	IP54	IP20	IP54	IP20

Technical Data

DRYVAC SYSTEMS DS

	20A(U) 45(S/C) b(T)	20S(U) 45(S/C) b(T)	20A(U) 65(S/C) b(T)	20S(U) 65(S/C) b(T)
Lubricant filling				
Screw	LVO 210 / 410	LVO 210 / 410	LVO 210 / 410	LVO 210 / 410
Roots	LVO 210	LVO 210 / 400	LVO 210	LVO 210 / 400
Total lubricant quantity (± 5 %)				
Screw LVO 210	1.2 l	1.2 l	1.2 l	1.2 l
Screw LVO 410	1.2 l	1.2 l	1.2 l	1.2 l
Roots LVO 210	3.6 l	3.6 l	3.6 l	3.6 l
Roots LVO 400		2.7 l		2.7 l
Roots LVO 410				
Intake flange	DN 160 ISO-K			
Discharge flange	DN 63 ISO-K			
Materials (components in contact with gas in the pump chamber)	Grey cast iron /graphite cast iron / steel/stainless steel /epoxy paint / FKM			
Materials sealing the pump off in the pump chamber towards the outside	FKM, grey cast iron			
Weight, approx. (± 40 kg)	1156 kg	1215 kg	1156 kg	1215 kg
Dimensions (L x W x H)				
Conn. flange, w/o acc., side exhaust	1349 x 700 x 1124 mm			
Conn. flange, w/o acc., rear exhaust	1355 x 660 x 1124 mm			
w acc., side exhaust (cf. hint ²⁾)				
w acc., rear exhaust (cf. hint ³⁾)				
Water				
Water connection	G1/2" (female)			
Water temperature				
pumps with LVO 210	5 – 35 °C			
pumps with LVO 400 / 410	5 – 25 °C			
Minimum supply pressure (unobstructed discharge, no backpressure)	2 bar(g) ⁵⁾			
Maximum supply pressure	6 bar(g) ⁵⁾			
Nominal flow				
Screw	6 l/min	6 l/min	7.5 l/min	7.5 l/min
Roots				
total	6 l/min	6 l/min	7.5 l/min	7.5 l/min
Purge gas				
Connection	plug-in connection D10			
Nominal setting pressure "Purge gas" (at nominal flow, valves open)	2.8 bar(g) ⁵⁾ (± 5 %)			
Permissible setting pressure "Purge gas" (at purge gas flow)	2.8 to 4.5 bar(g) ⁵⁾ (± 5 %)			
Permissible supply pressure "Purge gas"	4.0 to 10.0 bar(g) ⁵⁾ (± 5 %)			
Purge gas flow shaft seal 2.8 bar(g) nozzle out- / inlet (d = 0.9 / 2.0 mm)	22 / 92 slm (± 10 %)			
Rotor purge gas flow 2.8 bar(g) nozzle inlet (d = 1.0 mm)	28 slm (± 10 %)			

Technical Data

DRYVAC SYSTEMS DS

	25H(U) 45(S/C) b(T)	25H(U) 65(S/C) b(T)	25HF 45(S/C) b(T)	25HF 65(S/C) b(T)
Max. pump speed w/o gas ballast (50/60 Hz) (± 5 %)	2500 / 3000 m ³ /h ± 5 %		5000 m ³ /h ± 5 %	
Max. effective pumping speed (50/60 Hz) (± 5 %)	2100 / 2400 m ³ /h	2150 / 2500 m ³ /h	3500 m ³ /h	3750 m ³ /h
Ult. total pressure w/o rotor and inlet purge (± 10 %)	< 5 x 10 ⁻³ mbar			
Maximum permissible inlet pressure	1013 mbar			
Maximum permissible discharge pressure (relative to ambient)	+200 mbar			
Integral leak rate	< 1 x 10 ⁻⁴ mbar x l/s			
Water vapour tolerance with purge gas (SV40)	60 mbar ≥ 20 NI/min			
Water vapour capacity	15 kg/h	25 kg/h	15 kg/h	25 kg/h
Permissible ambient temperature	+5 ... + 35 °C			
Storage temperature	-10 ... + 60 °C			
Noise level (rigid exhaust pipe) ⁶⁾ Screw Roots	65 dB(A) (K _{pA} = 3dB) < 63 dB(A)			
Relative atmospheric humidity	95 %, non-condensing			
Installation location	up to 2000 m (NHN) ²⁾		up to 1000 m (NHN) ²⁾	
Cooling	Water			
Mains voltages and frequencies	380 – 440 V 50 Hz / 420 – 480 V 60 Hz		380 – 480 V 50/60 Hz	
Frequency (± 5 %)	50 / 60 Hz			
Phases	3-ph			
Rated power (400 V 50 Hz / 460 V 60 Hz) (± 0,8 kW) Screw Roots Roots with 18.5 kW (U) totalling totalling with 18.5 kW (U)	11 kW 6.2 / 7.4 kW 17.2 / 18.4 kW	15 kW 6.2 / 7.4 kW 21.2 / 22.4 kW	11 kW 11 kW 22 kW	15 kW 11 kW 26 kW
Rated current (400 V 50 Hz / 460 V 60 Hz) Screw Roots Roots with 18.5 kW (U) totalling totalling with 18.5 kW (U)	24 / 21 A 11.6 A 35.6 / 32.6 A	31 / 27 A 11.6 A 42 / 38.6 A	24 / 21 A 20 / 17 A 44 / 38 A	31 / 27 A 20 / 17 A 51 / 44 A
Power consumption at ultimate pressure (50/60Hz)	5.6 / 5.7 kW	7.8 / 7.9 kW	6.2 / 6.2 kW	8.4 / 8.4 kW
Motor efficiency class, calculated and configured acc. to EN 60034-30	IE2			
Electrical power rating (400 V 50 Hz / 460 V 60 Hz) Screw Roots Roots with 18.5 kW (U) totalling totalling with 18.5 kW (U)	17 / 14.9 kVA 8.4 kVA 25.4 / 23.3 kVA	21.8 / 19.1 kVA 8.4 kVA 30.2 / 27.5 kVA	17 / 14.9 kVA 14.2 / 12.1 kVA 31.2 / 27 kVA	21.8 / 19.1 kVA 14.2 / 12.1 kVA 36 / 31.2 kVA
Speed Screw / Roots (50 Hz) Screw / Roots (60 Hz)	7200 / 3000 rpm 7200 / 3600 rpm		7200 / 6000 rpm 7200 / 6000 rpm	
Min. permissible speed Screw ³⁾ Min. permissible speed Roots (off) ⁴⁾	1200 rpm off		1200 rpm 1200 rpm	
Protection class	IP54			

Technical Data

DRYVAC SYSTEMS DS

	25H(U) 45(S/C) b(T)	25H(U) 65(S/C) b(T)	25HF 45(S/C) b(T)	25HF 65(S/C) b(T)
Lubricant filling				
Screw	LVO 210 / 410			
Roots	LVO 210 / 410			
Total lubricant quantity (± 5 %)				
Screw LVO 210	1.2 l			
Screw LVO 410	1.2 l			
Roots LVO 210	1.2 l			
Roots LVO 400				
Roots LVO 410	1.2 l			
Intake flange	DN 250 ISO-K			
Discharge flange	DN 63 ISO-K			
Materials (components in contact with gas in the pump chamber)	Grey cast iron /graphite cast iron / steel/stainless steel /epoxy paint / FKM			
Materials sealing the pump off in the pump chamber towards the outside	FKM, grey cast iron			
Weight, approx. (± 40 kg)	1160 kg			1190 kg
Dimensions (L x W x H)				
Conn. flange, w/o acc., side exhaust	1349 x 700 x 1074 mm			
Conn. flange, w/o acc., rear exhaust	1355 x 660 x 1074 mm			
w acc., side exhaust (cf. hint ²⁾)				
w acc., rear exhaust (cf. hint ³⁾)				
Water				
Water connection	G1/2" (female)			
Water temperature				
pumps with LVO 210	5 – 35 °C			
pumps with LVO 400 / 410	5 – 25 °C			
Minimum supply pressure (unobstructed discharge, no backpressure)	2 bar(g) ⁵⁾			
Maximum supply pressure	6 bar(g) ⁵⁾			
Nominal flow				
Screw	6 l/min	7.5 l/min	6 l/min	7.5 l/min
Roots	2.2 l/min	2.2 l/min	2.2 l/min	2.2 l/min
total	8.2 l/min	9.7 l/min	8.2 l/min	9.7 l/min
Purge gas				
Connection	plug-in connection D10			
Nominal setting pressure "Purge gas" (at nominal flow, valves open)	2.8 bar(g) ⁵⁾ (± 5 %)			
Permissible setting pressure "Purge gas" (at purge gas flow)	2.8 to 4.5 bar(g) ⁵⁾ (± 5 %)			
Permissible supply pressure "Purge gas"	4.0 to 10.0 bar(g) ⁵⁾ (± 5 %)			
Purge gas flow shaft seal 2.8 bar(g) nozzle out- / inlet (d = 0.9 / 2.0 mm)	22 / 92 slm (± 10 %)			
Rotor purge gas flow 2.8 bar(g) nozzle inlet (d = 1.0 mm)	28 slm (± 10 %)			

Technical Data

DRYVAC SYSTEMS DS

	44H(U) 65(S/C) b(T)	44HF 65(S/C) b(T)	70H(U) 65(S/C) b(T)	70HF 65(S/C) b(T)
Max. pump speed w/o gas ballast (50/60 Hz) (± 5 %)	4400 / 5280 m³/h	7040 m³/h	7040 / 8 400 m³/h	9800 m³/h
Max. effective pumping speed (50/60 Hz) (± 5 %)	3600 / 4200 m³/h	5150 m³/h	5200 m³/h	6800 m³/h
Ult. total pressure w/o rotor and inlet purge (± 10 %)	< 5 x 10 ⁻³ mbar			
Maximum permissible inlet pressure	1013 mbar			
Maximum permissible discharge pressure (relative to ambient)	+200 mbar			
Integral leak rate	< 1 x 10 ⁻⁴ mbar x l/s			
Water vapour tolerance with purge gas (SV40)	60 mbar ≥ 20 NI/min			
Water vapour capacity	25 kg/h			
Permissible ambient temperature	+5 ... + 35 °C			
Storage temperature	-10 ... + 60 °C			
Noise level (rigid exhaust pipe) ⁶⁾ Screw Roots	65 dB(A) (K _{pA} = 3dB) < 63 dB(A)			
Relative atmospheric humidity	95 %, non-condensing			
Installation location	up to 2000 m	up to 1000 m	up to 2000 m	up to 1000 m
Cooling	Water			
Mains voltages and frequencies	380 – 440 V 50 Hz 420 – 480 V 60 Hz	380 – 480 V 50/60 Hz	380 – 440 V 50 Hz 420 – 480 V 60 Hz	380 – 480 V 50/60 Hz
Frequency (± 5 %)	50 / 60 Hz			
Phases	3-ph			
Rated power (400 V 50 Hz / 460 V 60 Hz) (± 0,8 kW) Screw Roots Roots with 18.5 kW (U) totalling totalling with 18.5 kW (U)	15 kW 11 kW 18,5 kW 26 kW 33,5 kW	15 kW 11 kW 26 kW	15 kW 11 kW 18,5 kW 26 kW 33,5 kW	15 kW 11 kW 26 kW
Rated current (400 V 50 Hz / 460 V 60 Hz) Screw Roots Roots with 18.5 kW (U) totalling totalling with 18.5 kW (U)	31 / 27 A 20 / 17 A 35 / 29 A 51 / 44 A 66 / 56 A	31 / 27 A 20 / 17 A 51 / 44 A	31 / 27 A 20 / 17 A 35 / 29 A 51 / 44 A 66 / 56 A	31 / 27 A 20 / 17 A 51 / 44 A
Power consumption at ultimate pressure (50/60 Hz)	8.1 / 8.3 kW	8.9 kW	8.1 / 8.3 kW	8.6 kW
Motor efficiency class, calculated and configured acc. to EN 60034-30	IE2			
Electrical power rating (400 V 50 Hz / 460 V 60 Hz) Screw Roots Roots with 18.5 kW (U) totalling totalling with 18.5 kW (U)	21.8 / 19.1 kVA 14.2 / 12.1 kVA 24.6 / 20.4 kVA 36 / 31.2 kVA 46.4 / 39.5 kVA	21.8 / 19.1 kVA 14.2 / 12.1 kVA 36 / 31.2 kVA	21.8 / 19.1 kVA 14.2 / 12.1 kVA 24.6 / 20.4 kVA 36 / 31.2 kVA 46.4 / 39.5 kVA	21.8 / 19.1 kVA 14.2 / 12.1 kVA 36 / 31.2 kVA
Speed Screw / Roots (50 Hz) Screw / Roots (60 Hz)	7200 / 3000 rpm 7200 / 3600 rpm	7200 / 4800 rpm 7200 / 4800 rpm	7200 / 3000 rpm 7200 / 3600 rpm	7200 / 4200 rpm 7200 / 4200/min
Min. permissible speed Screw ³⁾ Min. permissible speed Roots (off) ⁴⁾	1200 rpm off	1200 rpm 1200 rpm	1200 rpm off	1200 rpm 1200 rpm
Protection class	IP54			
Lubricant filling Screw Roots	LVO 210 / 410 LVO 210 / 400			

Technical Data

DRYVAC SYSTEMS DS

	44H(U) 65(S/C) b(T)	44HF 65(S/C) b(T)	70H(U) 65(S/C) b(T)	70HF 65(S/C) b(T)
Total lubricant quantity (± 5 %)				
Screw LVO 210	1.2 l			
Screw LVO 410	1.2 l			
Roots LVO 210	4.75 l			
Roots LVO 400	4.75 l			
Roots LVO 410				
Intake flange	DN 250 ISO-K	DN 320 ISO-K		
Discharge flange	DN 63 ISO-K			
Materials (components in contact with gas in the pump chamber)	Grey cast iron /graphite cast iron / steel/stainless steel /epoxy paint / FKM			
Materials sealing the pump off in the pump chamber towards the outside	FKM, grey cast iron			
Weight, approx. (± 40 kg)	1370 kg	1400 kg	1465 kg	1495 kg
Dimensions (L x W x H)				
Conn. flange, w/o acc., side exhaust	1349 x 700 x 1074 mm			1460 x 700 x 1076
Conn. flange, w/o acc., rear exhaust	1355 x 660 x 1074 mm			1460 x 660 x 1076
w acc., side exhaust (cf. hint ²⁾)				
w acc., rear exhaust (cf. hint ³⁾)				
Water				
Water connection	G1/2" (female)			
Water temperature				
pumps with LVO 210	5 – 35 °C			
pumps with LVO 400 / 410	5 – 25 °C			
Minimum supply pressure (unobstructed discharge, no backpressure)	2 bar(g) ⁵⁾			
Maximum supply pressure	6 bar(g) ⁵⁾			
Nominal flow				
Screw	7.5 l/min			
Roots	5.7 l/min			
total	13.2 l/min			
Purge gas				
Connection	plug-in connection D10			
Nominal setting pressure "Purge gas" (at nominal flow, valves open)	2.8 bar(g) ⁵⁾ (± 5 %)			
Permissible setting pressure "Purge gas" (at purge gas flow)	2,8 to 4.5 bar(g) ⁵⁾ (± 5 %)			
Permissible supply pressure "Purge gas"	4.0 to 10.0 bar(g) ⁵⁾ (± 5 %)			
Purge gas flow shaft seal 2.8 bar(g) nozzle out- / inlet (d = 0.9 / 2.0 mm)	22 / 92 slm			
Rotor purge gas flow 2.8 bar(g) nozzle inlet (d = 1.0 mm)	28 slm			

Additional information regarding the technical data

- Noise levels of > 100 dB(a) may occur with cyclic operation conditions, e.g. with load-lock operations or plain pump-downs. In this case we recommend to use RUVAC pumps with a pressure balance line („U“-pumps).
- The frequency converter standard ratings are valid for an installation altitude up to 1000 m. If the altitude exceeds 1000 m both the input voltage and the rated output current must be derated for 1% per 100 m.
- In case of overvoltage (> 480 V), bad cooling and permanent operation at nominal power the output power may be reduced in order to prevent thermal overload of the frequency converter. In case of undervoltage (< 380 V) the maximum power is not available by design.
- The minimum permissible frequency is 20 Hz for both the DRYVAC and the RUVAC. The minimum permissible speed is relevant for the oil lubrication of bearings and gears. Running the pump at less than the minimum speed for more than 1 hour can cause damage to the pump due to a lack of lubrication.
- bar(g): bar (gauge) is the overpressure, i.e. atmospheric pressure = 0 bar(g)
- Valid for 50Hz operations at ult. pressure conditions. Higher speeds, especially pressures >10 mbar, generate higher noise levels.

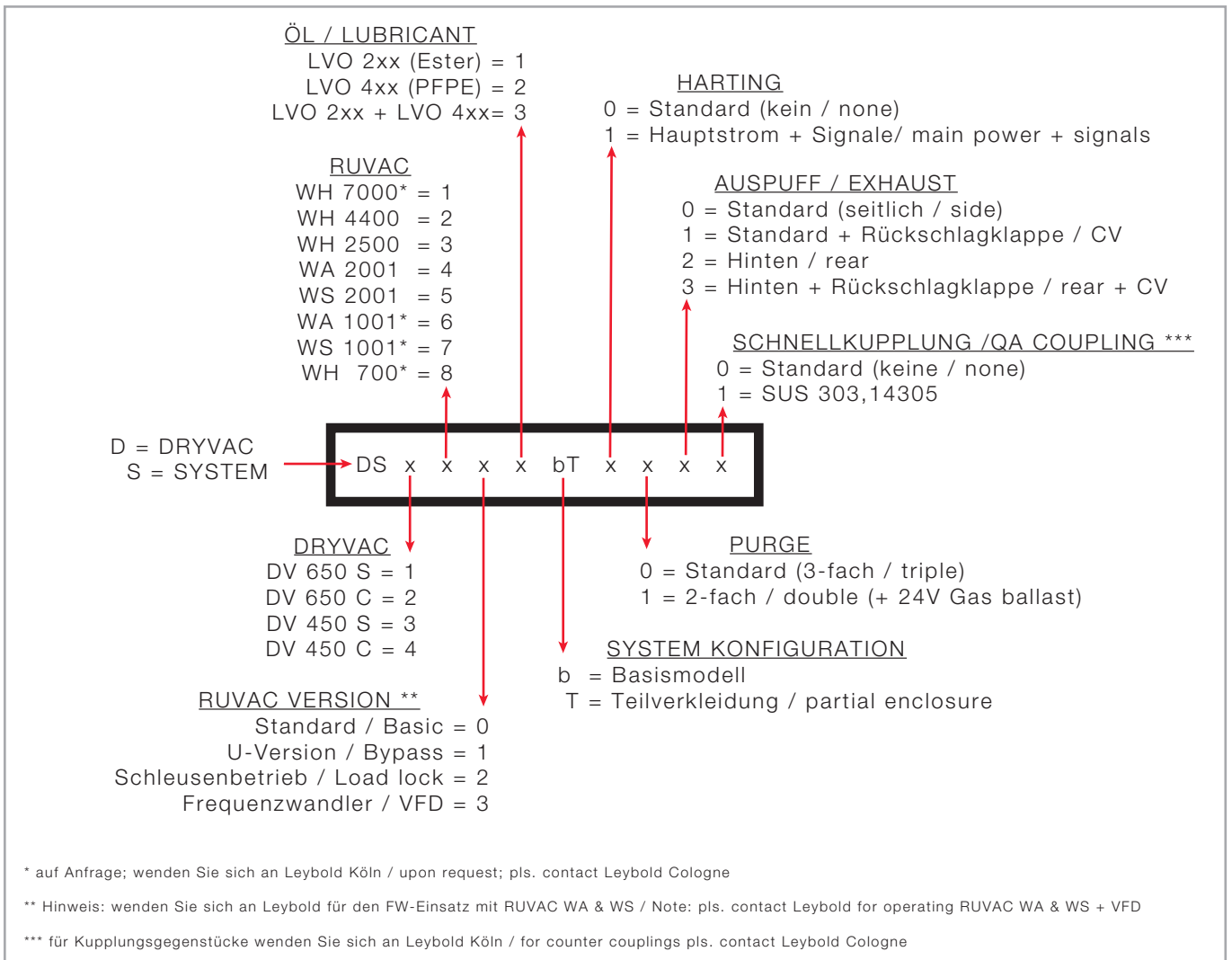

Configuration matrix

Part numbers for DRYVAC SYSTEMS are based on the matrix shown in the figure above and give hints on the individual configuration and features of the pump combination in question:

Ordering Information

DRYVAC SYSTEMS

Part No.	Description	Lubricants Screw	Lubricants Roots	Purge gas module	Exhaust / Check valve	Quick-release coupling (one-sided)
DS3411b0000	DS 20AU45S-b	LVO210	LVO210	triple	side / no	no
DS1411b0000	DS 20AU65S-b	LVO210	LVO210	triple	side / no	no
DS3301b0000	DS 25H45S-b	LVO210	LVO210	triple	side / no	no
DS1201b0000	DS 44H65S-b	LVO210	LVO210	triple	side / no	no
DS1211b0000	DS 44HU65S-b	LVO210	LVO210	triple	side / no	no
DS1212b0000	DS 44HU65S-b	LVO4x0	LVO4x0	triple	side / no	no
DS2512b0000	DS 20SU65C-b	LVO4x0	LVO4x0	triple	side / no	no
DS1511b0000	DS 20SU65S-b	LVO210	LVO210	triple	side / no	no
DS1301b0000	DS 25H65S-b	LVO210	LVO210	triple	side / no	no
DS1311b0000	DS 25HU65S-b	LVO210	LVO210	triple	side / no	no
DS1312b0000	DS 25HU65S-b	LVO4x0	LVO4x0	triple	side / no	no
DS3511b0000	DS 20SU45S-b	LVO210	LVO210	triple	side / no	no

... to be continued

Accessories

	Part No.
Synthetic Oil LEYBONOL LVO 210, 1 l	L21001
Synthetic Oil LEYBONOL LVO 210, 5 l	L21005
PFPE LEYBONOL LVO 400, 1 l	L40001
PFPE LEYBONOL LVO 410, 1 l	L41001
Roots pump adapter for DRYVAC for	
RUVAC WH 700	112005A03
RUVAC WS(U) 1001	112005A04
RUVAC WS(U) 2001	112005A05
RUVAC WH(U) 2500	112005A07
RUVAC WH(U) 4400/7000	112005A10
Non-return valve DRYVAC, DN 63 ISO-K	112005A15
Silencer	119002
DN 63 ISO-K for DRYVAC SYSTEMS	
Serviceable Silencer	119003V
DN 63 ISO-K for DRYVAC SYSTEMS	
External Display	155213V
Purge gas nozzle set for DRYVAC	112005A30
Permanent purge gas inlet kit	112005A32
Ground fixation	503637V001
Rotatable crane eyes (M 20 x 30; set of 4)	504397V901

GSD file and manual for the Profibus interface see the Leybold homepage.

Dry Compressing Pump Systems DRYVAC Smart System Configuration



The two-stage DRYVAC SYSTEMS consist of a combination of dry compressing Roots pumps and screw pumps. The Roots pump installed on top of the backing pump serves as a booster for increasing the pumping speed.

Various types of pumps may be used with DRYVAC SYSTEMS:

Roots Pumps

RUVAC WA
RUVAC WAU
RUVAC WH
RUVAC WHU
RUVAC WS
RUVAC WSU

Backing Pumps

DRYVAC DV S
DRYVAC DV C

All DRYVAC SYSTEMS (i versions) described hereinafter are equipped with:

- Microcontroller with touchscreen
- Connectivity options for gauge heads
- Harting connections (power supply)
- Digital I/O communication interface (DC37-P)
- Housing, castors and adjustable feet

They are water-cooled and lubricated either with synthetic oil or PFPE.

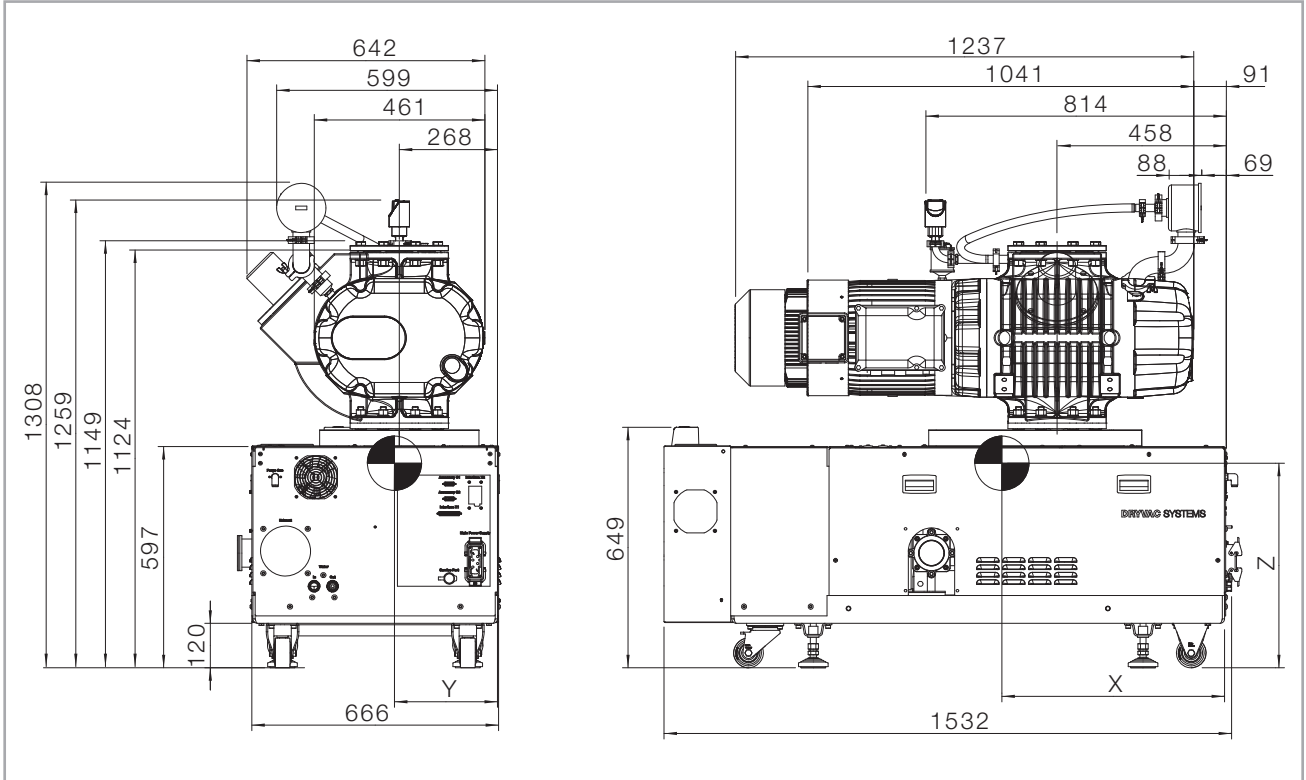

Dimensional drawing for DS 20A(U) 45(S/C) iT, DS 20A(U) 65(S/C) iT, DS 20S(U) 45(S/C) iT, DS 20S(U) 65(S/C) iT (Dimensions in mm)

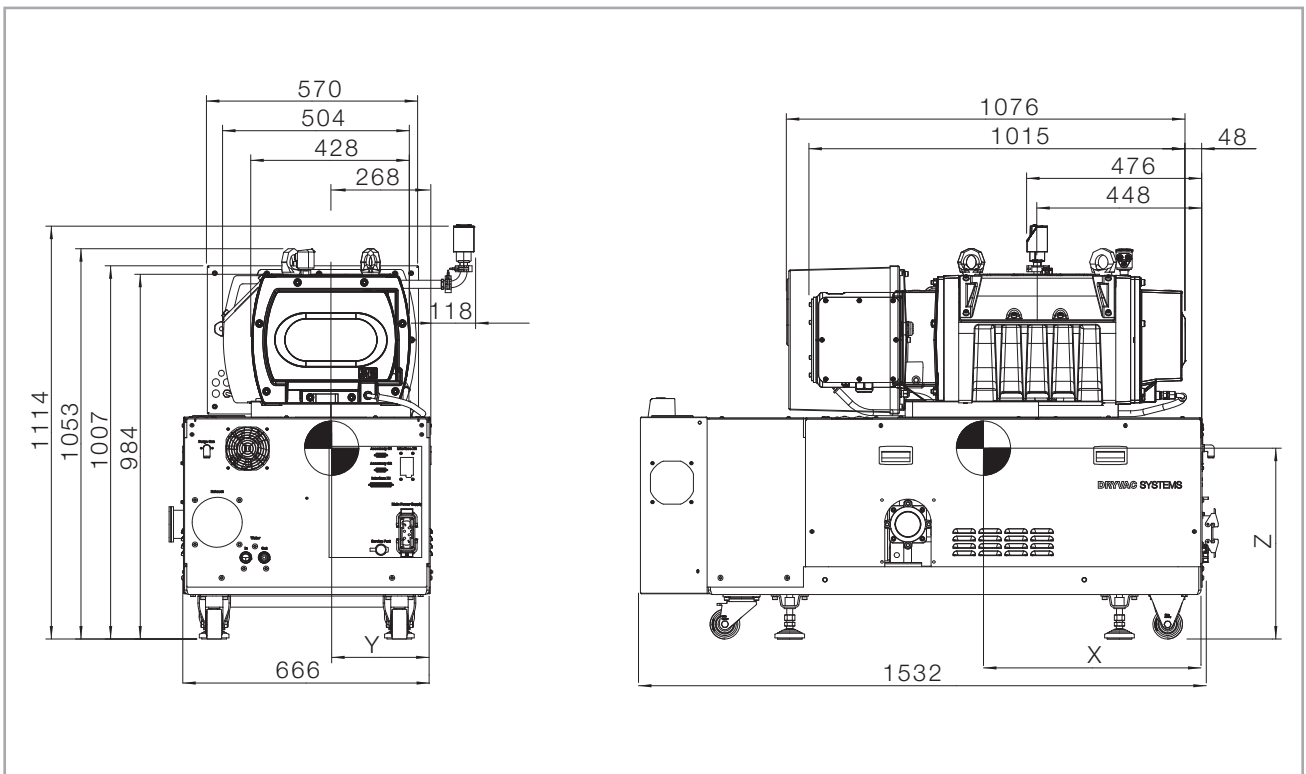

Dimensional drawing for DS 25H(U) 45(S/C) iT, DS25H(U) 65(S/C) iT, DS 25HF 45(S/C) iT, DS 25HF 65(S/C) iT (Dimensions in mm)

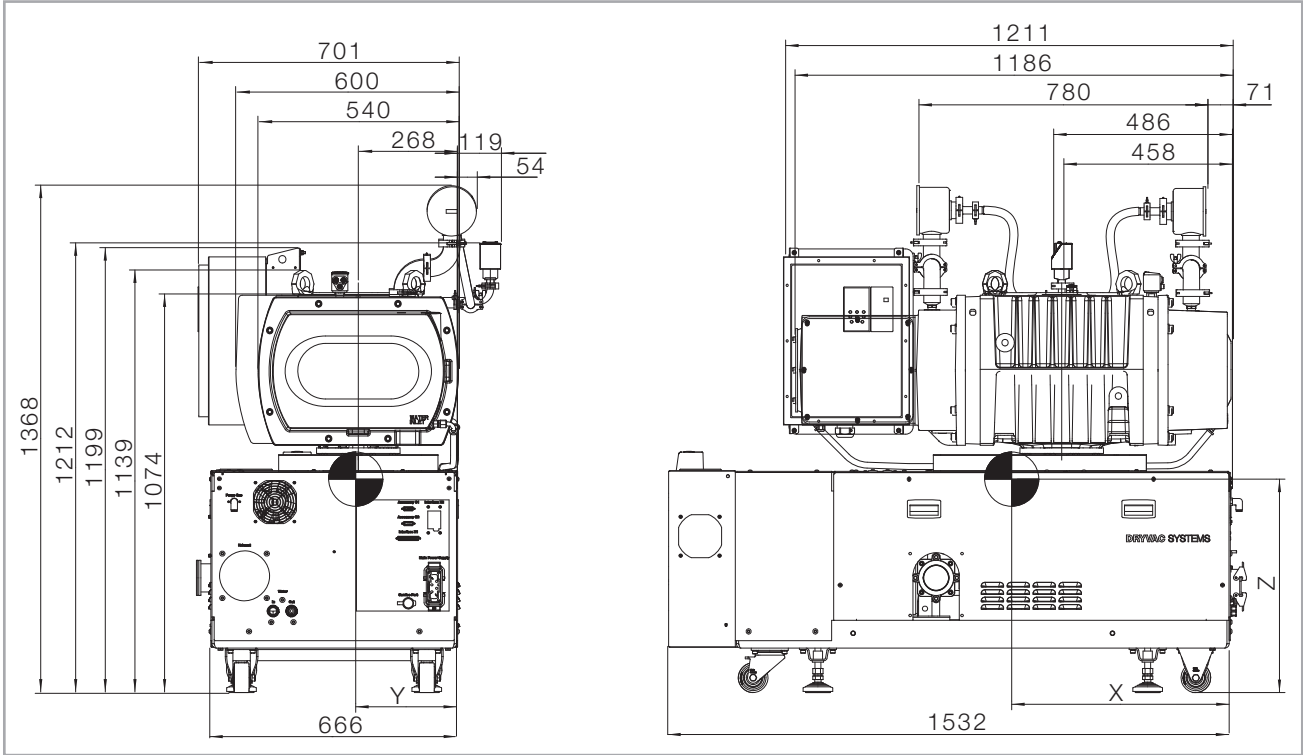

Dimensional drawing for DS 44H(U) 45(S/C) iT, DS 44H(U) 65(S/C) iT, DS 44HF 65(S/C) iT (Dimensions in mm)

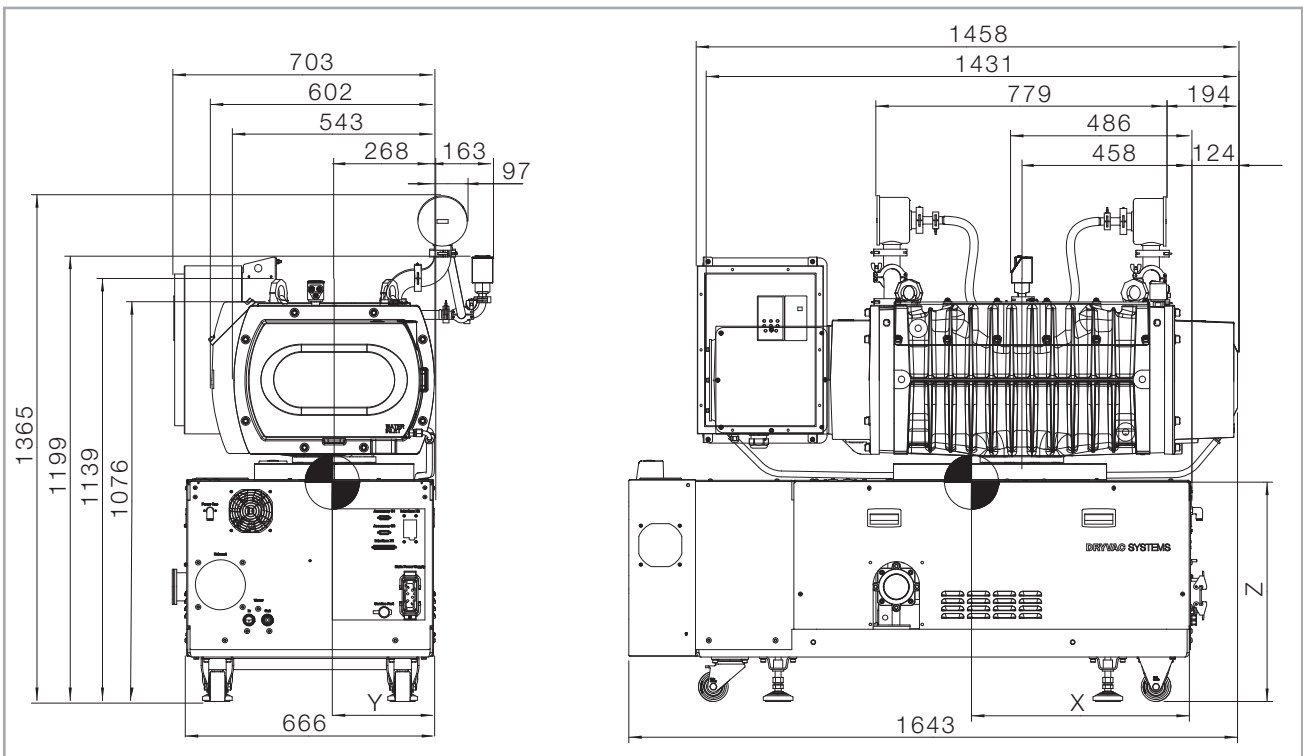

Dimensional drawing for DS 70H(U) 65(S/C) iT, DS 70HF 65(S/C) iT (Dimensions in mm)

Technical Data

DRYVAC SYSTEMS DS

	20A(U) 45(S/C) iT	20S(U) 45(S/C) iT	20A(U) 65(S/C) iT	20S(U) 65(S/C) iT
Max. pump speed w/o gas ballast (50/60 Hz) (± 5 %)	2000 / 2400 m ³ /h			
Max. effective pumping speed (50/60 Hz) (± 5 %)	1600 / 1850 m ³ /h		1750 / 2050 m ³ /h	
Ult. total pressure w/o rotor and inlet purge (± 10 %)	≤ 5 x 10 ⁻³ mbar			
Maximum permissible inlet pressure	1013 mbar			
Maximum permissible discharge pressure (relative to ambient)	+200 mbar			
Integral leak rate	< 5 x 10 ⁻⁴ mbar x l/s	< 1 x 10 ⁻⁴ mbar x l/s	< 5 x 10 ⁻⁴ mbar x l/s	< 1 x 10 ⁻⁴ mbar x l/s
Water vapour tolerance with purge gas (SV40)	60 mbar ≥ 20 NI/min			
Water vapour capacity	15 kg/h		25 kg/h	
Permissible ambient temperature	+5 ... + 35 °C			
Lagerungstemperatur	-10 ... + 60 °C			
Noise level (rigid exhaust pipe) ⁶⁾	65 dB(A) (K _{pA} = 3 dB)			
Screw				
Roots	< 80 dB(A)	< 72 dB(A)	< 80 dB(A)	< 72 dB(A)
Relative atmospheric humidity	95 %, non condensing			
Installation location	up to 2000 m (NHN) ²⁾			
Cooling	Water / air			
Mains voltages and frequencies	380 – 440 V 50 Hz / 420 – 480 V 60 Hz			
Frequency (± 5 %)	50 / 60 Hz			
Phases	3-ph			
Rated power				
at 400 V 50 Hz / 460 V 60 Hz				
at 400 V 50 Hz / 460 V 60 Hz with RUVAC 18,5 kW	18.5 kW	18.5 / 19.5 kW	22.5 kW	22.5 / 23.5 kW
Rated current at 400 V 50 Hz / 460 V 60Hz	38.1 / 33,5 A	39.5 / 36.5 A	45.1 / 39.5 A	46.5 / 42.5 A
Power consumption at ultimate pressure				
Motor efficiency class, calculated and configured acc. to EN 60034-30	IE2			
Electrical power rating				
400V 50Hz	26.4 kVA	27.4 kVA	31.2 kVA	32.2 kVA
460V 60Hz	23.2 kVA	25.3 kVA	27.4 kVA	29.4 kVA
RUVAC rated current f. motor protection				
380 – 440 V 50 Hz / 420 – 480 V 60 Hz	14 / 12 A	15 / 15 A	14 / 12 A	15 / 15 A
Speed Screw / Roots (50 Hz)	7200 / 3000 rpm			
Screw / Roots (60 Hz)	7200 / 3600 rpm			
Min. permissible speed Screw ³⁾	1200 rpm			
Min. permissible speed Roots (off) ⁴⁾	off			
Protection class	IP20			

Technical Data

DRYVAC-SYSTEM DS

	20A(U) 45(S/C) iT	20S(U) 45(S/C) iT	20A(U) 65(S/C) iT	20S(U) 65(S/C) iT
Lubricant filling				
Screw	LVO 210 / 410	LVO 210 / 410	LVO 210 / 410	LVO 210 / 410
Roots	LVO 210	LVO 210 / 400	LVO 210	LVO 210 / 400
Total lubricant quantity (± 5 %)				
Screw LVO 210	1.2 l	1.2 l	1.2 l	1.2 l
Screw LVO 410	1.2 l	1.2 l	1.2 l	1.2 l
Roots LVO 210	3.6 l	3.6 l	3.6 l	3.6 l
Roots LVO 400		2.7 l		2.7 l
Roots LVO 410				
Intake flange	DN 160 ISO-K			
Discharge flange	DN 63 ISO-K			
Materials (components in contact with gas in the pump chamber)	Grey cast iron /graphite cast iron / steel/stainless steel /epoxy paint / FKM			
Materials sealing the pump off in the pump chamber towards the outside	FKM, grey cast iron			
Weight, approx. (± 40 kg)	1156 kg	1215 kg	1156 kg	1215 kg
Dimensions (L x W x H)				
Conn. flange, w/o acc., side exhaust	1532 x 708 x 1124 mm			
Conn. flange, w/o acc., rear exhaust	1532 x 666 x 1124 mm			
w acc., side exhaust (cf. hint ²⁾)				
w acc., rear exhaust (cf. hint ³⁾)				
Water				
Water connection	G1/2" (female)			
Water temperature				
pumps with LVO 210	5 – 35 °C			
pumps with LVO 400 / 410	5 – 25 °C			
Minimum supply pressure (unobstructed discharge, no backpressure)	2 bar(g) ⁵⁾			
Maximum supply pressure	6 bar(g) ⁵⁾			
Nominal flow				
Screw	6 l/min	6 l/min	7.5 l/min	7.5 l/min
Roots				
total	6 l/min	6 l/min	7.5 l/min	7.5 l/min
Purge gas				
Connection	plug-in connection D10			
Nominal setting pressure "Purge gas" (at nominal flow, valves open)	2.8 bar(g) ⁵⁾ (± 5 %)			
Permissible setting pressure "Purge gas" (at purge gas flow)	2.8 to 4.5 bar(g) ⁵⁾ (± 5 %)			
Permissible supply pressure "Purge gas"	4.0 to 10.0 bar(g) ⁵⁾ (± 5 %)			
Purge gas flow shaft seal 2.8 bar(g) nozzle out- / inlet (d = 0.9 / 2.0 mm)	22 / 92 slm (± 10 %)			
Rotor purge gas flow 2.8 bar(g) nozzle inlet (d = 1.0 mm)	28 slm (± 10 %)			

Technical Data

DRYVAC-SYSTEM DS

	25H(U) 45(S/C) iT	25H(U) 65(S/C) iT	25HF 45(S/C) iT	25HF 65(S/C) iT
Max. pump speed w/o gas ballast (50/60 Hz) (± 5 %)	2500 / 3000 m³/h ± 5 %		5000 m³/h ± 5 %	
Max. effective pumping speed (50/60 Hz) (± 5 %)	2100 / 2400 m³/h	2150 / 2500 m³/h	3500 m³/h	3750 m³/h
Ult. total pressure w/o rotor and inlet purge (± 10 %)	< 5 x 10 ⁻³ mbar			
Maximum permissible inlet pressure	1013 mbar			
Maximum permissible discharge pressure (relative to ambient)	+200 mbar			
Integral leak rate	< 1 x 10 ⁻⁴ mbar x l/s			
Water vapour tolerance with purge gas (SV40)	60 mbar ≥ 20 NI/min			
Water vapour capacity	15 kg/h	25 kg/h	15 kg/h	25 kg/h
Permissible ambient temperature	+5 ... + 35 °C			
Lagerungstemperatur	-10 ... + 60 °C			
Noise level (rigid exhaust pipe) ⁶⁾ Screw Roots	65 dB(A) (K _{pA} = 3 dB) < 63 dB(A)			
Relative atmospheric humidity	95%, non condensing			
Installation location	up to 2000 m (NHN) ²⁾		up to 1000 m (NHN) ²⁾	
Cooling	Water			
Mains voltages and frequencies	380 – 440 V 50 Hz / 420 – 480 V 60 Hz		380 – 480 V 50/60 Hz	
Frequency (± 5 %)	50 / 60 Hz			
Phases	3-ph			
Rated power at 400 V 50 Hz / 460 V 60 Hz at 400 V 50 Hz / 460 V 60 Hz with RUVAC 18,5 kW	17.2 / 18.5 kW	21.1 / 22.5 kW	22 kW	26 kW
Rated current at 400 V 50 Hz / 460 V 60 Hz	36.1 / 33.1 A	43.1 / 39.1 A	44.5 / 38.5 A	51.5 / 44.5 A
Power consumption at ultimate pressure	5.6 / 5.7 kW	7.8 / 7.9 kW	6.2 / 6.2 kW	8.4 / 8.4 kW
Motor efficiency class, calculated and configured acc. to EN 60034-30	IE2			
Electrical power rating 400V 50Hz 460V 60Hz	25 kVA 22.9 kVA	29.9 kVA 27.1 kVA	30.8 kVA 26.7 kVA	35.7 kVA 30.8 kVA
RUVAC rated current f. motor protection 380 – 440 V 50 Hz / 420 – 480 V 60 Hz	12 / 12 A	12 / 12 A		
Speed Screw / Roots (50 Hz) Screw / Roots (60 Hz)	7200 / 3000 rpm 7200 / 3600 rpm		7200 / 6000 rpm 7200 / 6000 rpm	
Min. permissible speed Screw 3)	1200 rpm		1200 rpm	
Min. permissible speed Roots (off) 4)	off		1200 rpm	
Protection class	IP 20			

Technical Data

DRYVAC-SYSTEM DS

	25H(U) 45(S/C) iT	25H(U) 65(S/C) iT	25HF 45(S/C) iT	25HF 65(S/C) iT
Lubricant filling				
Screw	LVO 210 / 410			
Roots	LVO 210 / 410			
Total lubricant quantity (± 5 %)				
Screw LVO 210	1.2 l			
Screw LVO 410	1.2 l			
Roots LVO 210	1.2 l			
Roots LVO 400				
Roots LVO 410	1.2 l			
Intake flange	DN 250 ISO-K			
Discharge flange	DN 63 ISO-K			
Materials (components in contact with gas in the pump chamber)	Grey cast iron /graphite cast iron / steel/stainless steel /epoxy paint / FKM			
Materials sealing the pump off in the pump chamber towards the outside	FKM, grey cast iron			
Weight, approx. (± 40 kg)	1160 kg		1190 kg	
Dimensions (L x W x H)				
Conn. flange, w/o acc., side exhaust	1532 x 708 x 984 mm			
Conn. flange, w/o acc., rear exhaust	1532 x 666 x 984 mm			
w acc., side exhaust (cf. hint ²⁾)				
w acc., rear exhaust (cf. hint ³⁾)				
Water				
Water connection	G1/2" (female)			
Water temperature				
pumps with LVO 210	5 – 35 °C			
pumps with LVO 400 / 410	5 – 25 °C			
Minimum supply pressure (unobstructed discharge, no backpressure)	2 bar(g) ⁵⁾			
Maximum supply pressure	6 bar(g) ⁵⁾			
Nominal flow				
Screw	6 l/min	7.5 l/min	6 l/min	7.5 l/min
Roots	2.2 l/min	2.2 l/min	2.2 l/min	2.2 l/min
total	8.2 l/min	9.7 l/min	8.2 l/min	9.7 l/min
Purge gas				
Connection	plug-in connection D10			
Nominal setting pressure "Purge gas" (at nominal flow, valves open)	2.8 bar(g) ⁵⁾ (± 5 %)			
Permissible setting pressure "Purge gas" (at purge gas flow)	2.8 to 4.5 bar(g) ⁵⁾ (± 5 %)			
Permissible supply pressure "Purge gas"	4.0 to 10.0 bar(g) ⁵⁾ (± 5 %)			
Purge gas flow shaft seal 2.8 bar(g) nozzle out- / inlet (d = 0.9 / 2.0 mm)	22 / 92 slm (± 10 %)			
Rotor purge gas flow 2.8 bar(g) nozzle inlet (d = 1.0 mm)	28 slm (± 10 %)			

Technical Data

DRYVAC-SYSTEM DS

	44H(U) 65(S/C) iT	44HF 65(S/C) iT	70H(U) 65(S/C) iT	70HF 65(S/C) iT
Max. pump speed w/o gas ballast (50/60 Hz) (± 5 %)	4400 / 5280 m³/h	7040 m³/h	7040 / 8400 m³/h	9 800 m³/h
Max. effective pumping speed (50/60 Hz) (± 5 %)	3600 / 4200 m³/h	5150 m³/h	5200 m³/h	6 800 m³/h
Ult. total pressure w/o rotor and inlet purge (± 10 %)	< 5 x 10 ⁻³ mbar			
Maximum permissible inlet pressure	1013 mbar			
Maximum permissible discharge pressure (relative to ambient)	+200 mbar			
Integral leak rate	< 1 x 10 ⁻⁴ mbar x l/s			
Water vapour tolerance with purge gas (SV40)	60 mbar ≥ 20 NI/min			
Water vapour capacity	25 kg/h			
Permissible ambient temperature	+5 ... + 35 °C			
Lagerungstemperatur	-10 ... + 60 °C			
Noise level (rigid exhaust pipe) ⁶⁾ Screw Roots	65 dB(A) (K _{pA} = 3 dB) < 63 dB(A)			
Relative atmospheric humidity	95 %, non condensing			
Installation location	up to 2000 m	up to 1000 m	up to 2000 m	up to 1000 m
Cooling	Water			
Mains voltages and frequencies	380 – 440 V 50 Hz 420 – 480 V 60 Hz	380 – 480 V 50/60 Hz	380 – 440 V 50 Hz 420 – 480 V 60 Hz	380 – 480 V 50/60 Hz
Frequency (± 5 %)	50 / 60 Hz			
Phases	3-ph			
Rated power at 400 V 50 Hz / 460 V 60 Hz at 400 V 50 Hz / 460 V 60 Hz with RUVAC 18,5 kW	26 kW			
Rated current at 400 V 50 Hz / 460 V 60 Hz	51.5 / 44.5 A	51.5 / 44.5 A	51.5 / 44.5 A	51.5 / 44.5 A
Power consumption at ultimate pressure	8.1 / 8.3 kW	8.9 kW	8.1 / 8.3 kW	8.6 kW
Motor efficiency class, calculated and configured acc. to EN 60034-30	IE2			
Electrical power rating 400V 50 Hz 460V 60 Hz	35.7 kVA 30.8 kVA			
RUVAC rated current f. motor protection 380 – 440V 50Hz / 420 – 480V 60Hz	20 / 17 A		20 / 17 A	
Speed Screw / Roots (50 Hz) Screw / Roots (60 Hz)	35 / 29 A		35 / 29 A	
Min. permissible speed Screw ³⁾ Min. permissible speed Roots (off) ⁴⁾	7200 / 3000 rpm 7200 / 3600 rpm	7200 / 4800 rpm 7200 / 4800 rpm	7200 / 3,000 rpm 7200 / 3,600 rpm	7200 / 4200 rpm 7200 / 4200 rpm
Protection class	1200 rpm off	1200 rpm 1200 rpm	1200 rpm off	
Schutzart	IP20			
Lubricant filling Screw Roots	LVO 210 / 410 LVO 210 / 400			
Total lubricant quantity (± 5 %) Screw LVO 210 Screw LVO 410 Roots LVO 210 Roots LVO 400 Roots LVO 410	1.2 l 1.2 l 4.75 l 4.75 l 4.75 l			

Technical Data

DRYVAC-SYSTEM DS

	44H(U) 65(S/C) iT	44HF 65(S/C) iT	70H(U) 65(S/C) iT	70HF 65(S/C) iT
Intake flange	DN 250 ISO-K	DN 320 ISO-K		
Discharge flange	DN 63 ISO-K			
Materials (components in contact with gas in the pump chamber)	Grey cast iron /graphite cast iron / steel/stainless steel /epoxy paint / FKM			
Materials sealing the pump off in the pump chamber towards the outside	FKM, grey cast iron			
Weight, approx. (\pm 40 kg)	1370 kg	1400 kg	1465 kg	1495 kg
Dimensions (L x W x H)				
Conn. flange, w/o acc., side exhaust	1532 x 708 x 1074 mm		1643 x 708 x 1074 mm	
Conn. flange, w/o acc., rear exhaust w acc., side exhaust (cf. hint ²⁾)	1532 x 666 x 1074 mm		1643 x 666 x 1074 mm	
w acc., rear exhaust (cf. hint ³⁾)				
Water				
Water connection	G1/2" (female)			
Water temperature				
pumps with LVO 210	5 – 35 °C			
pumps with LVO 400 / 410	5 – 25 °C			
Minimum supply pressure (unobstructed discharge, no backpressure)	2 bar(g) ⁵⁾			
Maximum supply pressure	6 bar(g) ⁵⁾			
Nominal flow				
Screw	7.5 l/min			
Roots	5.7 l/min			
total	13.2 l/min			
Purge gas				
Connection	plug-in connection D10			
Nominal setting pressure "Purge gas" (at nominal flow, valves open)	2.8 bar(g) ⁵⁾ (\pm 5 %)			
Permissible setting pressure "Purge gas" (at purge gas flow)	2.8 to 4.5 bar(g) ⁵⁾ (\pm 5 %)			
Permissible supply pressure "Purge gas"	4.0 to 10.0 bar(g) ⁵⁾ (\pm 5 %)			
Purge gas flow shaft seal 2.8 bar(g) nozzle out- / inlet (d = 0.9 / 2.0 mm)	22 / 92 slm (\pm 10 %)			
Rotor purge gas flow 2.8 bar(g) nozzle inlet (d = 1.0 mm)	28 slm (\pm 10 %)			

Additional information regarding the technical data

- Noise levels of > 100 dB(a) may occur with cyclic operation conditions, e.g. with load-lock operations or plain pump-downs. In this case we recommend to use RUVAC pumps with a pressure balance line („U“-pumps).
- The frequency converter standard ratings are valid for an installation altitude up to 1000 m. If the altitude exceeds 1000 m both the input voltage and the rated output current must be derated for 1% per 100 m.
- In case of overvoltage (> 480 V), bad cooling and permanent operation at nominal power the output power may be reduced in order to prevent thermal overload of the frequency converter. In case of undervoltage (< 380 V) the maximum power is not available by design.
- The minimum permissible frequency is 20 Hz for both the DRYVAC and the RUVAC.
The minimum permissible speed is relevant for the oil lubrication of bearings and gears. Running the pump at less than the minimum speed for more than 1 hour can cause damage to the pump due to a lack of lubrication.
- bar(g): bar (gauge) is the overpressure, i.e. atmospheric pressure = 0 bar(g)
- Valid for 50Hz operations at ult. pressure conditions. Higher speeds, especially pressures >10 mbar, generate higher noise levels.

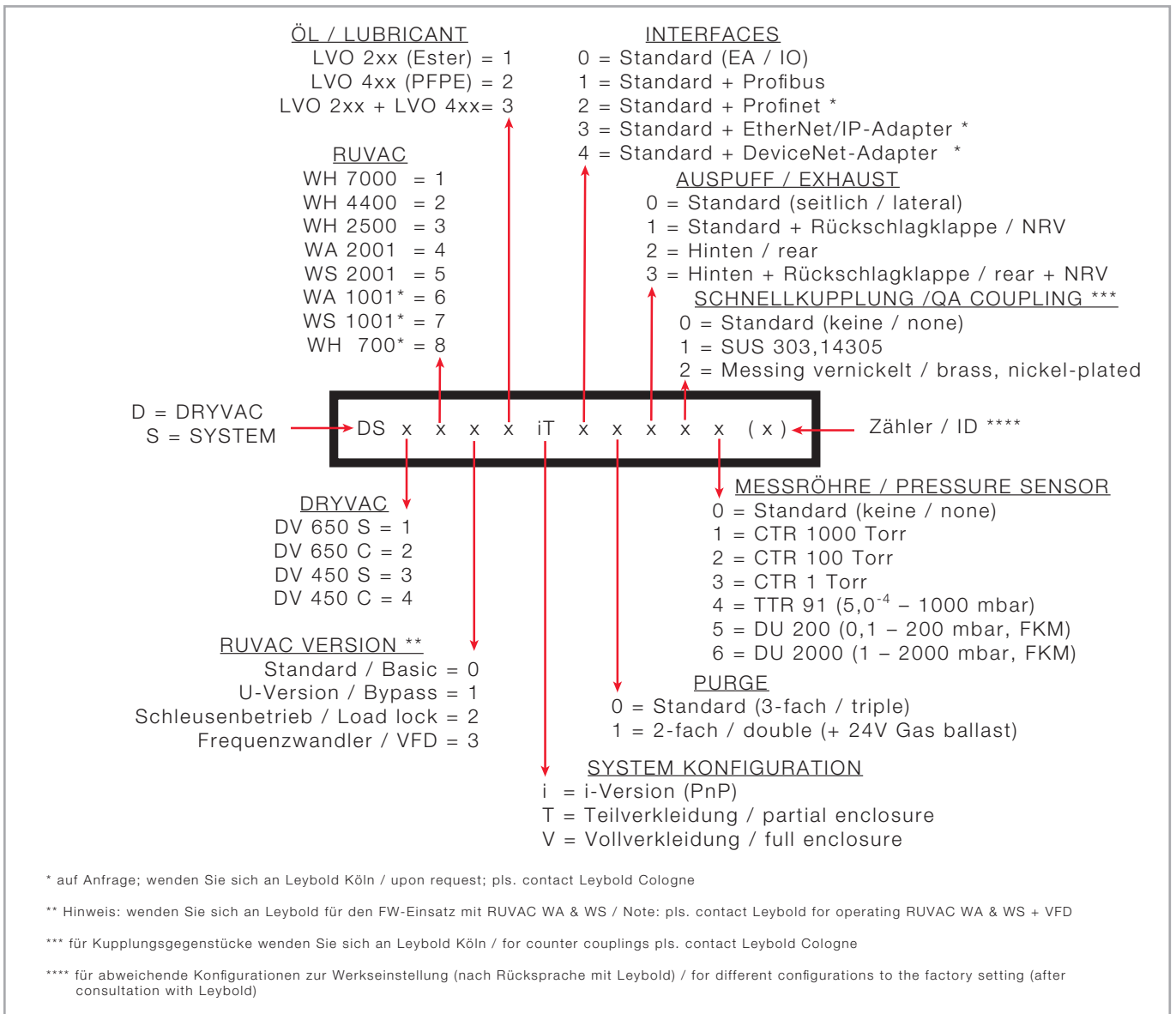

Configuration matrix

Part numbers for DRYVAC SYSTEMS are based on the matrix shown in the figure above and give hints on the individual configuration and features of the pump combination in question:

Ordering Information

DRYVAC SYSTEMS

Part No.	Description	Lubricants Screw	Lubricants Roots	Purge gas module	Exhaust / Check valve	Quick-release coupling (one-sided)
DS3411iT00000	DS 20AU45S iT	LVO210	LVO210	triple	side / no	no
DS1411iT00000	DS 20AU65S iT	LVO210	LVO210	triple	side / no	no
DS2512iT00000	DS 20SU65C iT	LVO410	LVO400	triple	side / no	no
DS1512iT00000	DS 20SU65S iT	LVO410	LVO400	triple	side / no	no
DS1511iT00000	DS 20SU65S iT	LVO210	LVO210	triple	side / no	no
DS2302iT00000	DS 25H65C iT	LVO410	LVO410	triple	side / no	no
DS1303iT00320	DS 25H65S iT	LVO210	LVO410	triple	rear / yes	yes
DS1303iT00000	DS 25H65S iT	LVO210	LVO410	triple	side / no	no
DS4332iT00320	DS 25HF45C iT	LVO410	LVO410	triple	rear / yes	yes
DS3332iT00320	DS 25HF45S iT	LVO410	LVO410	triple	rear / yes	yes
DS3331iT00000	DS 25HF45S iT	LVO210	LVO210	triple	side / no	no
DS2332iT00320	DS 25HF65C iT	LVO410	LVO410	triple	rear / yes	yes
DS1333iT00320	DS 25HF65S iT	LVO210	LVO410	triple	rear / yes	yes
DS3313iT00320	DS 25HU45S iT	LVO210	LVO410	triple	rear / yes	yes
DS1313iT00320	DS 25HU65S iT	LVO210	LVO410	triple	rear / yes	yes
DS1311iT00000	DS 25HU65S iT	LVO210	LVO210	triple	side / no	no
DS2202iT00000	DS 44H65C iT	LVO410	LVO400	triple	side / no	no
DS1201iT00000	DS 44H65S iT	LVO210	LVO210	triple	side / no	no
DS2232iT00320	DS 44HF65C iT	LVO410	LVO400	triple	rear / yes	yes
DS1223iT00320	DS 44HU65S iT	LVO210	LVO400	triple	rear / yes	yes
DS1223iT00000	DS 44HU65S iT	LVO210	LVO400	triple	side / no	no
DS1212iT00000	DS 44HU65S iT	LVO410	LVO400	triple	side / no	no
DS1211iT00000	DS 44HU65S iT	LVO210	LVO210	triple	side / no	no
DS2132iT00320	DS 70HF65C iT	LVO410	LVO400	triple	rear / yes	yes

... to be continued

Accessories

	Part No.
Synthetic Oil LEYBONOL LVO 210, 1 l	L21001
Synthetic Oil LEYBONOL LVO 210, 5 l	L21005
PFPE LEYBONOL LVO 400, 1 l	L40001
PFPE LEYBONOL LVO 410, 1 l	L41001
Silencer DN 63 ISO-K for DRYVAC SYSTEMS	119002
Serviceable Silencer DN 63 ISO-K for DRYVAC SYSTEMS	119003V
Harting plug for DRYVAC S-i/RS-i/DV-i/DVR-i	112 005A20
Active sensors / gauge heads	
Kit CTR 1 Torr	504391V901
Kit CTR 100 Torr	504392V901
Kit CTR 1000 Torr	504393V901
Kit DU 200	504394V901
Kit DU 2000	504395V901
Kit TTR 91	504396V901
Rotatable crane eyes (M 20 x 30; set of 4)	504397V901
Counter coupling water, BNP	504406V901
Counter coupling water, stainless-steel	504407V901

GSD file and manual for the Profibus interface see the Leybold homepage.

Dry Compressing Pump Systems DRYVAC PowerBoost



The DRYVAC SYSTEM 44HUF65S IV (DS 4465-U2) consists of a combination of a dry compressing screw pump and a Roots pump. Its design has been specifically optimized for a fast load lock pump-downs, it is equipped with an automatic cycle detection system, and the Roots pump shows a special speed management. Thus, with an optimum utilization of the power, the mechanical stress due to pressure bursts was minimized, and the noise level during pump-downs was significantly reduced.

Furthermore the system described hereinafter is equipped with:

- integrated frequency converters
- Microcontroller with touchscreen
- digital I/O communication interface (DC37-P)
- Harting connections (power supply)
- housing, castors and adjustable feet

The system is water-cooled and lubricated with synthetic oil.

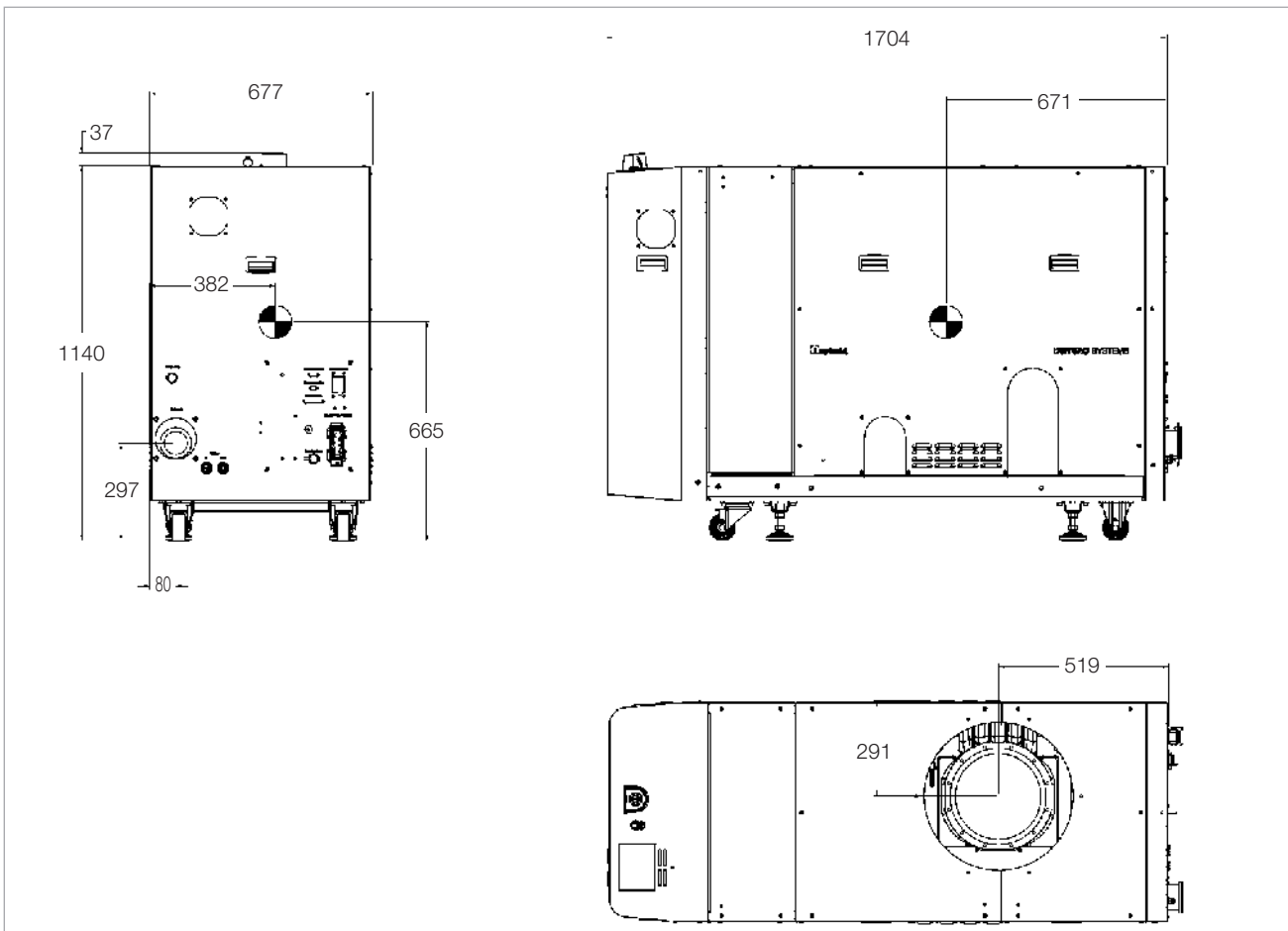

Dimensional drawing for PowerBoost DS 4465 U2 (Dimensions in mm)

Technical Data

DRYVAC SYSTEM DS 44HUF65S iV

Ultimate total pressure w/o purge gas or with purge gas for shaft seal outlet ($\pm 10\%$)	$< 5 \times 10^{-3}$ mbar
Maximum permissible inlet pressure	1050 mbar
Maximum permissible discharge pressure (relative to ambient)	+200 mbar
Integral leak rate	$< 1 \times 10^{-4}$ mbar x l/s
Permissible gas inlet temperature	+5 ... +40 °C
Permissible ambient temperature	+5 ... +30 °C
Storage temperature	-10 ... +60 °C
Noise level with rigid exhaust pipe, at ultimate pressure (acc. to DIN EN ISO 2151)	Screw = 65 dB(A) Roots = 63 dB(A) ⁵⁾ ($K_{pA} = 3$ dB)
Relative atmospheric humidity	95 %, non-condensing
Installation location	up to 1000 m (NHN) ¹⁾
Cooling	Water
Mains voltage	360 – 440 V 50/60 Hz ²⁾
Frequency ($\pm 5\%$)	50 / 60 Hz
Phasen	3-ph
Rated power at 400 V ($\pm 0,8$ kW)	57 kW
Rated current at 400 V	95 A
Power consumption at ultimate pressure ($\pm 0,8$ kW)	9 kW
Motor efficiency class, calculated and configured acc. to EN 60034-30	IE2
Min. permissible speed ³⁾	1200 rpm
Protection class	IP20
Lubricant filling	LVO 210
Total lubricant quantity ($\pm 5\%$)	5.7 l
Intake flange	DN 250 ISO-K
Discharge flange	DN 63 ISO-K
Materials (components in contact with gas in the pump chamber)	Grey cast iron /graphite cast iron / steel/stainless steel /epoxy paint / FKM
Materials sealing the pump off in the pump chamber towards the outside	FKM, grey cast iron
Weight, approx. (± 40 kg)	1500 kg
Dimensions (L x W x H) (± 10 mm)	1704 x 677 x 1140 mm
Water	
Water connection	G1/2" (female)
Water temperature	5 – 35 °C
Minimum supply pressure (unobstructed discharge, no backpressure)	2 bar(g) ⁴⁾
Maximum supply pressure	7 bar(g) ⁴⁾
Nominal flow	14 l/min

Technical Data

DRYVAC SYSTEM DS 44HUF65S iV

Purge gas	
Connection	G1/4" (female)
Nominal setting pressure "Purge gas" (at nominal flow, valves open)	2.8 bar(g) ⁴⁾
Permissible setting pressure "Purge gas" (at purge gas flow)	2.8 to 4.5 bar(g) ⁴⁾
Permissible supply pressure "Purge gas"	4.0 to 10.0 bar(g) ⁴⁾
Purge gas flow shaft seal inlet (d = 2.0 mm) / outlet (d = 0.9 mm) at nominal setting pressure (2.8 bar(g)) at max. setting pressure (3.5 bar(g))	92 slm / 22 slm 107 slm / 26 slm

Additional information regarding the technical data

- 1) The frequency converter standard ratings are valid for an installation altitude up to 1000 m. If the altitude exceeds 1000 m both the input voltage and the rated output current must be derated for 1% per 100 m.
- 2) In case of undervoltage (< 380 V) the maximum power is not available by design.
- 3) The minimum permissible frequency is 20 Hz for both the DRYVAC and the RUVAC.
The minimum permissible speed is relevant for the oil lubrication of bearings and gears. Running the pump at less than the minimum speed for more than 1 hour can cause damage to the pump due to a lack of lubrication.
- 4) bar(g): bar (gauge) is the overpressure, i.e. atmospheric pressure = 0 bar(g)
- 5) The noise level is significantly higher due to flow generated noises during load lock operations. Its accurate value depends on the operational mode used as well as the intake line's design. The pump system DS 44HUF65S iV is equipped with an automatic cycle detection system. With detecting vacuum cycles the pump system will reduce the noise level to a minimum during pump-downs.

Ordering Information

DRYVAC-SYSTEM DS

44HUF65S iV

	Part No.
DRYVAC PowerBoost	
DS 4465 U2	DS1241iV01320
Harting plug for 100 A	504613V901
Counter coupling water, BNP	504406V901
DRYVAC PowerBoost Plus	
DS 4465 U2	DS1241iV01320
Harting plug for 100 A	504613V901
DV650 Plus Upgrade kit	504595V901
Harting plug for 65 A	112005A20
Counter coupling water, BNP (2x)	504406V901

Accessories

	Part No.
Synthetic Oil LEYBONOL LVO 210, 1 litre	L21001
Floor mount (optional; set of 4 with foundation bolts)	503637V001
Rotatable crane eyes	6521504

RUVAC RAV Roots Vacuum Pumps with Pre-Admission Cooling

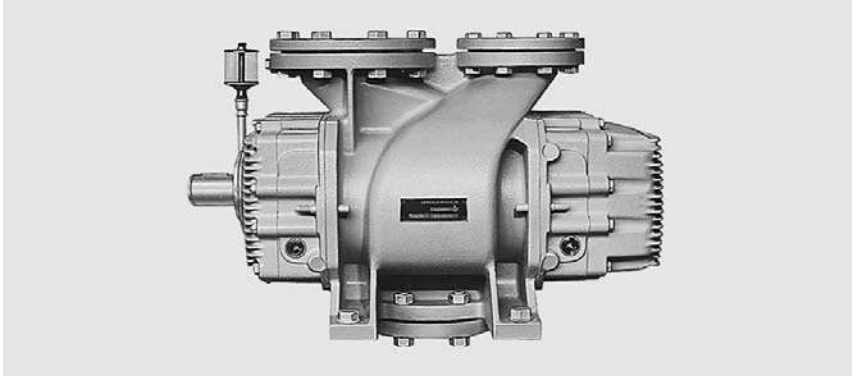

Typical Applications

- Short pump-down cycles on large volumes
- Oil-free compression of high volume flows of gases and vapors against atmospheric pressure
- Single-stage (G) or in combination with RAV F as backing pump
- Operating pressures in the rough vacuum range
- CE approval

Advantages to the User

- **RUVAC RAV G**
Operating pressure range of 150 mbar (112.5 Torr) against atmospheric pressure; total leak rate $< 10^{-1}$ mbar x l/s (7.5×10^{-2} Torr x l/s)
- **RUVAC RAV F**
In combination with backing pumps the attainable operating pressures extend down into the medium vacuum range;
- leak rate $< 10^{-2}$ mbar x l/s (7.5×10^{-3} Torr x l/s)
- When series-connected the operating pressures extend down into the medium vacuum range:
 - two-stages to 25 mbar (18.75 Torr)
 - multiple stage to 10^{-3} mbar (7.5×10^{-4} Torr)
- Motors for special supply voltages and frequencies or protected types are available
- Pre-admission silencer and filter for the cooling gas inlet as well as silencers for the exhaust side (option/single-stage)
- Downstream gas cooler (option/multistage)
- C version (chemical version/option)
- Special materials (option)
- Pressure burst resistant version (option)

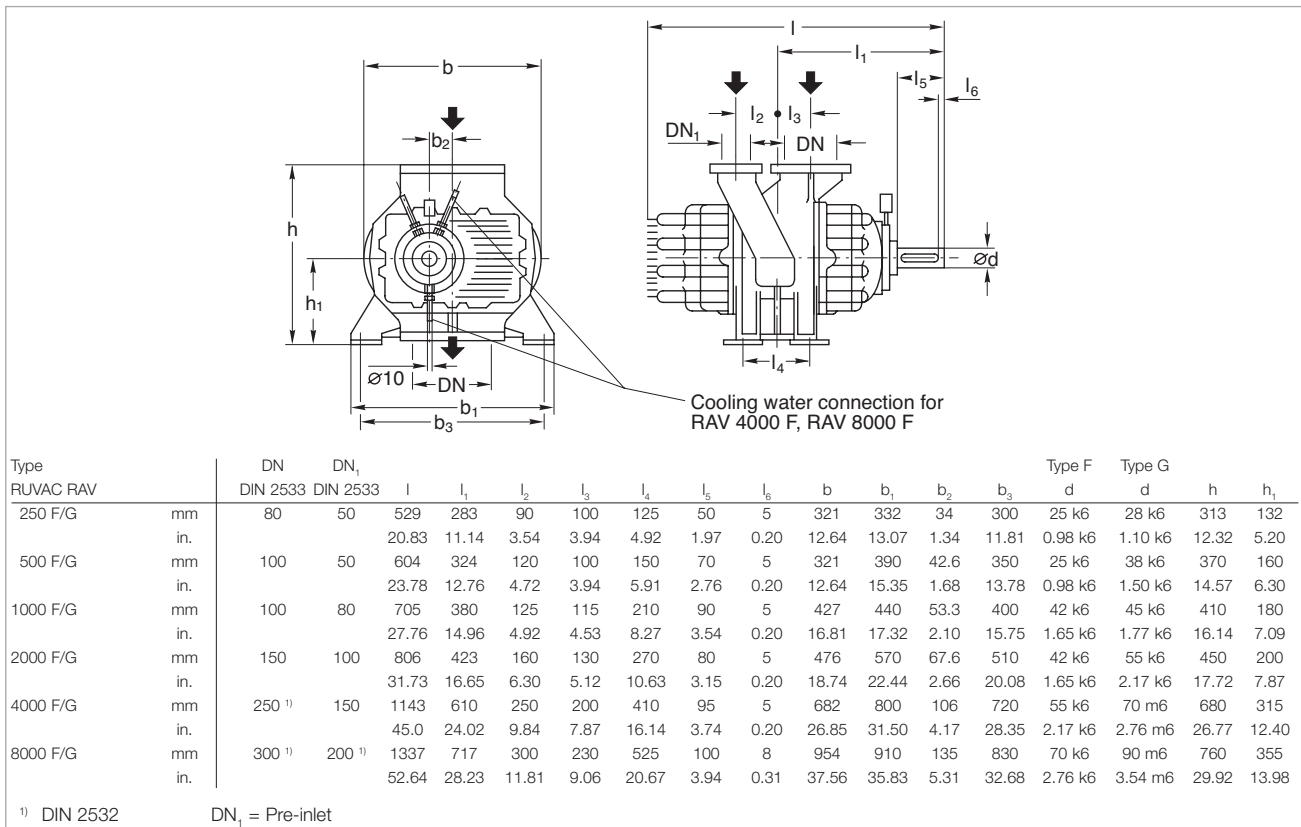

Dimensional drawing for the RUVAC RAV pumps

Technical Data, 50 Hz

		RUVAC RAV					
		250 G	500 G	1000 G	2000 G	4000 G	8000 G
Pumping speed ¹⁾	m ³ /h (cfm)	250 (147)	500 (295)	1000 (589)	2000 (1178)	3700 (2179)	8100 (4771)
Nominal speed	min ⁻¹ (rpm)	3000 (3000)	3000 (3000)	3000 (3000)	3000 (3000)	1500 (1500)	1500 (1500)
Max. permissible pressure difference ²⁾	mbar (Torr)	850 (637)	850 (637)	850 (637)	850 (637)	850 (637)	850 (637)
Connecting flange	DN	80	100	100	150	250	300
Max. permissible motor power	for direct drive						
	for belt drive						
	kW (hp)	11.0 (15.0)	18.5 (25.2)	30.0 (40.8)	55.0 (74.8)	95.0 (129.3)	200.0 (272.1)
	kW (hp)	11.0 (15.0)	18.5 (25.2)	30.0 (40.8)	55.0 (74.8)	95.0 (129.3)	200.0 (272.1)
Weight	kg (lbs)	95 (210)	160 (353)	225 (496)	310 (684)	720 (1588)	1230 (2712)

Ordering Information

		RUVAC RAV					
		250 G	500 G	1000 G	2000 G	4000 G	8000 G
		Part No.	Part No.	Part No.	Part No.	Part No.	Part No.
Roots vacuum pump RUVAC RAV G		upon request	upon request	upon request	upon request	upon request	upon request

Technical Data, 50 Hz

		RUVAC RAV					
		250 F	500 F	1000 F	2000 F	4000 F	8000 F
Pumping speed ¹⁾	m ³ /h (cfm)	250 (147)	500 (295)	1000 (589)	2000 (1178)	3700 (2179)	8100 (4771)
Nominal speed	min ⁻¹ (rpm)	3000 (3000)	3000 (3000)	3000 (3000)	3000 (3000)	1500 (1500)	1500 (1500)
Max. permissible pressure difference ²⁾	mbar (Torr)	850 (637)	850 (637)	850 (637)	850 (637)	850 (637)	850 (637)
Connecting flange	DN	80	100	100	150	250	300
Max. permissible motor power	for direct drive						
	for belt drive						
	kW (hp)	11.0 (15.0)	18.5 (25.2)	30.0 (40.8)	55.0 (74.8)	95.0 (129.3)	200.0 (272.1)
	kW (hp)	4.0 (5.4)	4.0 (5.4)	7.5 (10.2)	15.0 (20.4)	37.0 (50.3)	75 (102.0)
Gear oil, approx.	l (qt)	0.9 (0.95)	1.1 (1.6)	1.5 (1.59)	2.5 (2.64)	12.0 (12.68)	11.0 (11.63)
Weight, approx.	kg (lbs)	95 (210)	160 (353)	225 (496)	310 (684)	720 (1588)	1230 (2712)
Cooling water connection, fitting for tube		-	-	-	-	10 x 1	10 x 1
Cooling water requirement, approx.	l x h ⁻¹	-	-	-	-	60	60

Ordering Information

		RUVAC RAV					
		250 F	500 F	1000 F	2000 F	4000 F	8000 F
		Part No.	Part No.	Part No.	Part No.	Part No.	Part No.
Roots vacuum pump RUVAC RAV F		upon request	upon request	upon request	upon request	upon request	upon request

¹⁾ To DIN 28 400 and following numbers

²⁾ RUVAC RAV G and RAV F with direct drive

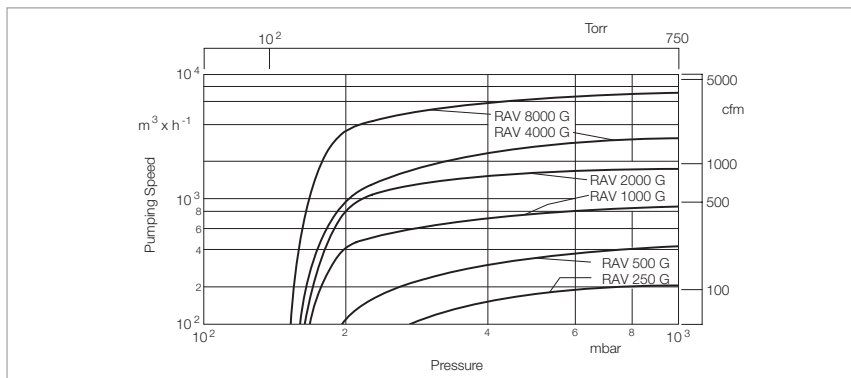

Pumping speed diagram of RUVAC RAV at 50 Hz

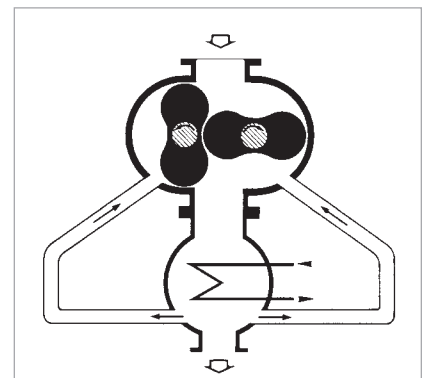

Operating diagram of RUVAC RAV vacuum pumps with pre-admission cooling

TVD Pump Systems for Drying, Evaporation and Distillation Applications

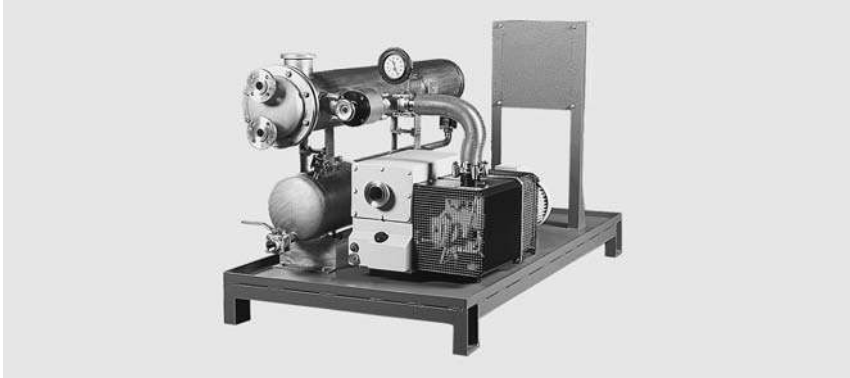

TVD 200

Advantages to the User

- Operating agent may be reused, for example by returning cleaned water to the process
- Reduction of the quantities which need to be disposed of by 80%
- Low temperature distillation/drying
- Condensate may be drained during vacuum operation
- CE approval

Typical Applications

- Drying of powders and solids, for example
- Cleaning of waste water
- Vacuum distillation

Standard Equipment

- Condenser at the intake side
- Receiver with condensate level indicator
- Manually operated valves on the receiver
- SOGEVAC rotary vane vacuum pump with integrated exhaust filters, anti-suckback valve and gas ballast valve

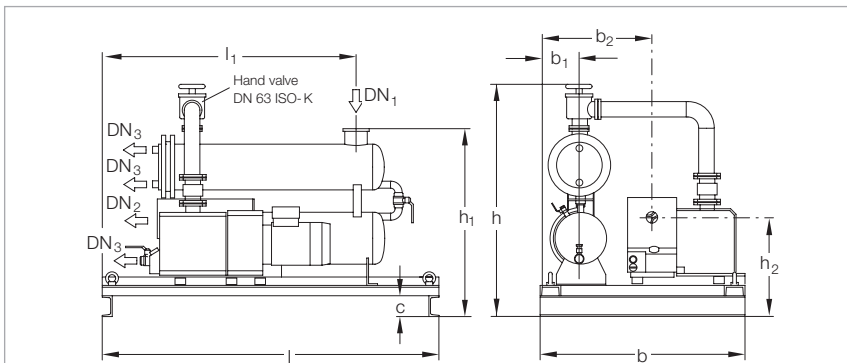

Type	DN ₁	DN ₂	DN ₃	l	l ₁	b	b ₁	b ₂	h	h ₁	h ₂	c
TVD 40 mm	63 ISO-K	1 1/4"	1"	1000	590	700	160	445	1000	785	341	100
in.			1"	39.37	23.23	27.56	6.30	17.52	39.37	30.91	13.43	3.94
TVD 65 mm	63 ISO-K	1 1/4"	1"	1280	755	700	160	445	1165	950	341	100
in.			1"	50.39	29.72	27.56	6.30	17.52	45.87	33.46	13.43	3.94
TVD 100 mm	100 ISO-K	2"	1"	1400	755	940	160	561	1165	950	345	100
in.			1"	55.12	29.72	37.01	6.30	22.09	45.87	33.46	13.58	3.94
TVD 200 mm	100 ISO-K	2"	1"	1800	765	940	150	501	1175	960	473	100
in.			1"	70.87	30.12	37.01	6.30	19.72	46.25	37.80	18.62	3.94

Dimensional drawing for the TVD pump systems

Options

- Valve between condenser and rotary vane vacuum pump
- Pressure gauge for checking the condensate pressure
- Solenoid valves at the receiver
- Receiver with proximity switch for monitoring the condensate level
- Electric control for automatic operation of the pump system
- Mobile pallet with castors
- Cold water replacement for mobile applications

Technical Data, 50 Hz**TVD 40****TVD 65****TVD 100****TVD 200**

Condenser, effective surface area, approx.	m ²	1	2	3	5
Receiver, usable volume	l (qt)	30.0 (31.71)	50.0 (52.85)	50.0 (52.85)	50.0 (52.85)
Rotary vane vacuum pump	SOGEVAC	SV 40	SV 65	SV 100	SV 200
Nominal pumping speed	m ³ /h (cfm)	46.0 (27.1)	65.0 (38.3)	100.0 (58.9)	180.0 (106.0)
Pumping speed at 50 Hz for air	m ³ /h (cfm)	46.0 (27.1)	53.0 (31.2)	94.0 (55.4)	170.0 (100.1)
for water vapor at 50 mbar (37.5 Torr)	m ³ /h (cfm)	280.0 (165.0)	560.0 (330.0)	840.0 (495.0)	1400.0 (825.0)
Ultimate total pressure with standard gas ballast	mbar (Torr)	< 1.5 (< 1.1)	< 1.5 (< 1.1)	< 1.5 (< 1.1)	< 0.7 (< 0.53)
Noise level ¹⁾	dB(A)	63	64	70	69
Condensing capacity for water	l x h ⁻¹	10	20	30	50
Installed motor power 400 V, 50 Hz	kW (hp)	1.1 (1.5)	1.5 (2.0)	2.2 (3.0)	4.0 (4.2)

¹⁾ Operating at ultimate pressure with gas ballast

Technical Data, 50 Hz**SV 40****SV 65****SV 100****SV 200**

Weight (with oil filling), approx.	kg (lbs)	125 (276)	150 (331)	200 (441)	300 (662)
Oil filling	l (qt)	2.0 (2.11)	2.0 (2.11)	3.5 (3.70)	5.0 (5.29)
Connecting flanges					
Inlet port	DN ₁	63 ISO-K	63 ISO-K	100 ISO-K	100 ISO-K
Outlet port	DN ₂	1 1/4"	1 1/4"	2"	2"

Ordering Information**TVD 40****TVD 65****TVD 100****TVD 200**

	Part No.	Part No.	Part No.	Part No.
Pump system	021 01	021 02	021 03	021 04

Accessories for oil sealed and dry compressing Pump Systems

Sound Proofing

A sound proofing box is available as an optional extra so as to reduce the noise down to the permissible level.

Depending on the size of the pumping system, noise reductions between 15 and 20 dB(A) are obtained using our standard sound proofing arrangements.

Custom designs of the sound proofing box allow the noise level to be reduced by up to 35 dB(A).



RUTA RA 3001/S630F/G with sound proofing box

The maintenance side is designed as a door component. A window insert may be provided in the door or in the side walls to facilitate checking of the oil levels.

Ventilation is performed by means of an electric fan, the fresh air and exhaust ducts are located within the sound proofing box. Further optional extras which may be fitted include closed air circulation with integrated, water-cooled heat exchanger and a connection port for a central exhaust system.

Isolation against Vibrations

RUTA vacuum pump systems produce only slight vibrations. To reduce these vibrations even further, vibration absorbers can be fitted under the pump system.

Dust Separators

Vacuum processes where large amounts of particles or dusts are contributed by the process require special devices to protect the vacuum pumps.

Leybold has developed – even for high flow rate applications – special dust separators, which can be installed ahead of the intake of the RUTA vacuum pump systems. The dust separators have two stages. The first stage is a cyclone that collects dust particles of coarse and medium size, the fine dust are trapped in filter elements. Dust separators are customdesigned for the specific process and the required pumping speed.

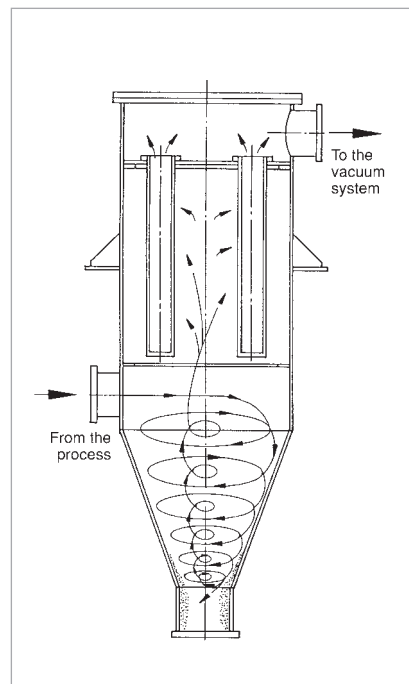

Diagrammatic section through a dust separator

Dust Filter without Cyclone

See further down in this chapter.

Filtering surface suitable for pumping speeds	m ²	0.2	0.5	1.0	2.0	3.0	5.0
min.	m ³ /h (cfm)	100 (58.9)	300 (176.7)	600 (353.4)	1000 (589)	1500 (883.5)	3000 (1767)
max.	m ³ /h (cfm)	300 (176.7)	800 (471.2)	1500 (883.5)	3000 (1767)	4000 (2356)	8000 (4712)
Reduction of pumping speed at							
≤ 1 mbar (< 0.75 Torr)	%	11	11	11	11	11	11
≤ 6 mbar (< 4.5 Torr)	%	9	9	9	9	9	9
≤ 20 mbar (< 15 Torr)	%	5	5	5	5	5	5
without dust load							

Frequency converter RUVATRONIC RT 5

The electronic frequency inverters RUVATRONIC RT 5/251 to 5/16000 have been designed specially for use in connection with Leybold Roots pumps of the RUVAC type. For each Roots vacuum pump size, a matching frequency converter is available.

The main characteristics of the RUVATRONIC RT 5 are:

Simulation of a pressure equalization line

The software of the frequency inverters is adapted to each pump and ensures that the risk of mechanically overloading the pump can be excluded. In the case of too high pressure differences, the rotational speed will be decreased

automatically until the load is reduced to within the pump's limits.

RUVAC Roots vacuum pumps of the types WA, WS and RA (without pressure equalization line) can be switched on together with the forepump at atmospheric pressure. Through this, the pumpdown time can be reduced drastically. The minimum pumping speed of the backing pump needs to be considered in this case.

Pump	Required pumping speed for the backing pump
WA/WS 251	50 m ³ /h (29 cfm)
WA/WS 501	100 m ³ /h (59 cfm)
WA/WS 1001	200 m ³ /h (118 cfm)
WA/WS 2001	410 m ³ /h (241 cfm)
RA 3001	650 m ³ /h (383 cfm)
RA 5001	930 m ³ /h (547 cfm)
RA 7001	1250 m ³ /h (736 cfm)
RA 9001	3240 m ³ /h (1907 cfm)

Operation at up to 3 predefined speeds

Via floating contacts, the pump can be operated at one of the 3 predefined speeds. Switching over to another pre-defined speed is possible during operation.

Operation at any rotational speed

With a 0 to 10 V signal, any speed can be pre-defined to operate the pump between the minimum and maximum rotational speed. The software reliably ensures that the rotational speed cannot drop below the minimum speed or exceed the maximum speed.

Increase in the pumping speed

By operating the Roots vacuum pumps at frequencies over 50 Hz, the nominal pumping speed of the pumps can be increased. Depending on the type of pump, an increase between 20 and 100% is possible.

Note

Please enquire about possible application limitations (process dependent).

Electric Controller

In order to drive all electrical appliances within the pump systems, the pump systems may be equipped with standard control cabinets which contain:

- Motor protection switch (rated for the pumps used in each case)
- Contactors
- Main switch interlocked in accordance with VDE 0113
- Relays for necessary control/sub-systems
- ON/OFF push-button for each pump
- Power supply for the installed monitoring facilities
- Fault indicators arranged on a lamp panel
- Switch-over (through an external contact) from local to remote operation.

The control cabinet may be fitted either to the frame of the pump system or it may be wallmounted.

Beside the standard systems, we manufacture control systems for much more complex systems:

- Remote control module as a 19" rack module (1/4 width, 3 HU). The start/stop push-buttons and the related indicators for operation and fault are located on the front panel
- Pre- and post-operation control
- Pressure dependent control
- Time-dependent control
- Program control
- Control for explosion hazard areas
- Combinations of the aforementioned versions
- Programmable control (PC)
- Vacuum gauge with pressure read-out in the control cabinet.

Pressure Control

Basically there are several ways in which to control the pressure.

The equipment which is supplied as standard for the **DOWNSTREAM** or **BYPASS** control systems selected by Leybold consists of:

- Pressure measurement
- Controller with control unit
- Control valve with position indicator
- Engineering.

The **Downstream Control System** throttles the pumping speed of the vacuum pump by changing the conductance of the valve.

The advantages offered by this arrangement are:

- No supply of other gases
- Closed system
- The intake pressure of the pump system is lower than its operating pressure (thus saving energy, among other things).

The second method is the **Bypass Control System**. Here the pressure is maintained at a constant level by admitting an additional quantity of gas.

The advantages offered by this arrangement are:

- Simple design
- Much smaller valve
- No reduction of the intermediate pressure within the pump.

In order to design a pressure control system we need the following information:

- Amount of gas
- Type of gas
- Pressure
- Length of the piping
- Type of auxiliary energy (electric/pneumatic)
- Explosion protection required yes/no.

Additional complex control arrangements are available, for example with:

- Adjustable pressure characteristic
- Adjustable timing
- Speed control
- Combination with other control facilities.

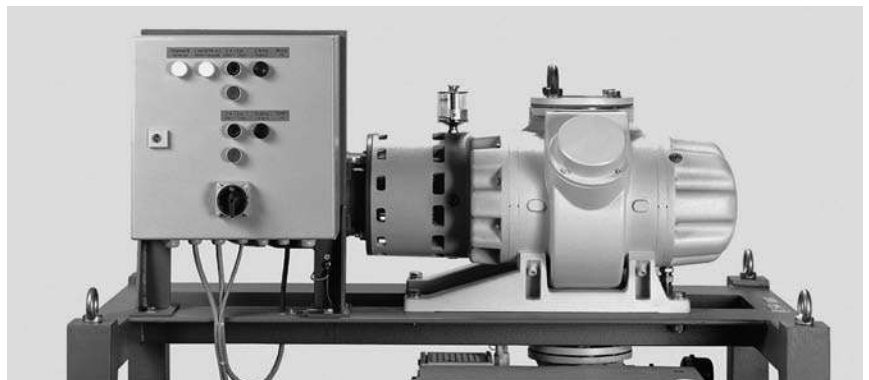

Control panel on RUTA WAU1001/SV200/G

Dust Filter F-xxx-C

The highly efficient dust filters F-xxx-C are fitted to the inlet of the RUVAC pumps. The filter protects the Roots vacuum pumps against the intake of dust.

The dust filters are equipped with an easy to replace filter element. In the case of the filters F-1001-C or larger, the gas enters into the housing above the filter element. Thus the likelihood of puncturing the filter is reduced.

In the case of the dust filter F-501-C, the filter element is protected by a baffle.

All vacuum dust filters are rated for pressures up to 1200 mbar (900 Torr) abs. max.

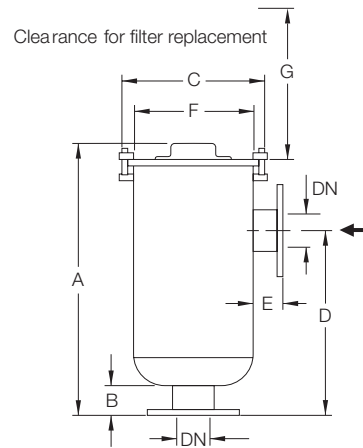

Type		DN	A	B	∅ C	D	E	F	G
F-501-C	mm	65 ¹⁾	312	76	222	185	76	195	235
	in.		12.28	2.99	8.74	7.28	2.99	7.68	9.25
F-1001-C	mm	100 ¹⁾	692	76	356	470	74	310	381
	in.		27.24	2.99	14.02	18.50	2.91	12.20	15.00
F-2001-C	mm	150 ¹⁾	740	102	470	521	102	406	254
	in.		29.13	4.02	18.50	20.51	4.02	15.98	10.00
F-2001-C plus	mm	150 ¹⁾	740	102	470	521	99	413	508
	in.		29.13	4.02	18.50	20.51	3.90	16.26	20.00
F-5001-C	mm	200 ²⁾	1031	102	572	648	103	505	508
	in.		40.59	4.02	22.52	25.51	4.02	19.88	20.00
F-7001-C	mm	250 ²⁾	1454	102	686	1143	99	616	838
	in.		57.24	4.02	27.01	45.00	3.90	24.33	32.99
F-9001-C	mm	300 ²⁾	1454	102	686	1143	99	616	838
	in.		57.24	4.02	27.01	45.00	3.90	24.33	32.99
F-13001-C	mm	300 ²⁾	1784	102	686	1448	99	616	635
	in.		70.24	4.02	27.01	57.01	3.90	24.33	25.00

¹⁾ The hole pattern corresponds to PN 6 and may be connected by using collar flanges to ISO-K components

²⁾ The hole pattern corresponds to PN 10

Dimensional drawing for the dust filters F-xxx-C

Technical Data

Dust Filter F-xxx-C

		Polyester filter cartridge	Paper filter cartridge
Separation at 10 µm	%	> 99.9	–
Separation at 5 µm	%	> 99	> 99.9
Separation at 2 µm	%	–	> 99
Temperature	°C (°F)	-25 to +100 (-13 to +212)	-25 to +100 (-13 to +212)
Dust filter for WA/WS/WAU/WSU 501 WA/WS/WAU/WSU 1001, WH 700 WA/WS/WAU/WSU 2001, WH 2500 RA 3001, RA 5001, WH 4400, WH 7000 RA 7001 RA 9001 RA 13000		F-501-C F-1001-C F-2001-C / F-2001-C plus F-5001-C F-7001-C F-9001-C F-13001-C	F-501-C F-1001-C F-2001-C / F-2001-C plus F-5001-C F-7001-C F-9001-C F-13001-C

Technical Data

Dust Filter

		F-501-C	F-1001-C	F-2001-C	F-2001-C plus
Surface area, approx.					
Polyester	m ²	0.4	1.0	1.5	2.6
Paper	m ²	1.3	3.0	4.0	6.3
Weight, approx.	kg (lbs)	7.0 (15.45)	29.0 (64.02)	50.0 (110.38)	51.0 (112.58)

Technical Data

Dust Filter

		F-5001-C	F-7001-C	F-9001-C	F-13001-C
Surface area, approx.					
Polyester	m ²	4.5	9.0	9.0	14.0
Paper	m ²	11.5	26.0	26.0	37.0
Weight, approx.	kg (lbs)	83.0 (138.22)	171.0 (377.48)	171.0 (377.48)	209.0 (461.37)

Ordering Information

Dust Filter F-xxx-C

	Part No.	Part No.
Dust Filter	Polyester filter element	Paper filter element
F-501-C	500 001 403	500 001 404
Replacement filter element FE-501-C	500 005 629	500 005 630
F-1001-C	500 000 301	500 000 302
Replacement filter element FE-1001-C	500 000 313	500 000 314
F-2001-C	500 000 303	500 000 304
Replacement filter element FE-2001-C	500 000 315	500 000 316
F-2001-C plus ¹⁾	500 001 367	500 001 368
Replacement filter element FE-2001-C plus	500 005 631	500 005 632
F-5001-C	500 000 305	500 000 306
Replacement filter element FE-5001-C	500 000 317	500 000 318
F-7001-C	500 000 307	500 000 308
Replacement filter element FE-7001/9001-C	500 000 319	500 000 320 (2 pieces are required)
F-9001-C	500 000 309	500 000 310
Replacement filter element FE-7001/9001-C	500 000 319	500 000 320 (2 pieces are required)
F-13001-C	500 000 311	500 000 312
Replacement filter element FE-13001-C	500 000 321 (2 pieces are required)	500 000 322 (2 pieces are required)

¹⁾ For increased quantities of dust

Bellows with Vibration Absorbers



Bellows with vibration absorbers

The bellows serve the purpose of connecting pipes to vacuum pumps without introducing any mechanical tensions.

Technical Data

Bellows with Vibration Absorbers

		KIT DN 63 ISO-K	KIT DN 100 ISO-K	KIT DN 160 ISO-K
Length	mm (in.)	132 (5.20)	132 (5.20)	150 (5.91)
Lateral movement, max.	mm (in.)	7.5 (0.30)	9.5 (0.37)	3.5 (0.14)
Axial movement, max.	mm (in.)	20 (0.79)	28 (1.10)	22 (0.87)

Ordering Information

Bellows with Vibration Absorbers

		KIT DN 63 ISO-K	KIT DN 100 ISO-K	KIT DN 160 ISO-K
		Part No.	Part No.	Part No.
Bellows with vibration absorbers		503 189 V001	503 189 V002	503 189 V003
consisting of				
Bellows	Quantity	1	1	1
Centering ring	Quantity	2	2	2
Clamp (set of 4 pieces)	Quantity	2	2	2
Support bracket	Quantity	4	8	8
Rubber/metal absorber	Quantity	2	4	4
Hexagon nut M 12	Quantity	12	24	24
Threaded rod M 12				
105 mm long	Quantity	4	8	8
Washer	Quantity	12	24	24

Technical Data

Bellows with Vibration Absorbers

		KIT DN 200 ISO-K	KIT DN 250 ISO-K	KIT DN 320 ISO-K
Length	mm (in.)	150 (5.91)	200 (7.87)	250 (9.84)
Lateral movement, max.	mm (in.)	3.5 (0.14)	4.5 (0.18)	4.5 (0.18)
Axial movement, max.	mm (in.)	20 (0.79)	30	50

Ordering Information

Bellows with Vibration Absorbers

		KIT DN 200 ISO-K	KIT DN 250 ISO-K	KIT DN 320 ISO-K
		Part No.	Part No.	Part No.
Bellows with vibration absorbers		503 189 V004	503 189 V005	503 189 V006
consisting of				
Bellows	Quantity	1	1	1
Centering ring	Quantity	2	2	2
Clamp (set of 4 pieces)	Quantity	3	3	4
Support bracket	Quantity	12	12	16
Rubber/metal absorber	Quantity	6	6	8
Hexagon nut M 12	Quantity	36	36	48
Threaded rod M 12				
90 mm long	Quantity	12	12	–
105 mm long	Quantity	–	–	16
Washer	Quantity	36	36	48

Bus Interfaces for Monitoring



Wi-Fi and Profibus interface kit for SP-GUARD

Bus interfaces for remote reading of the SP-GUARD monitoring system for the screw pumps SCREWLINE SP 250 and SP 630. Item can be ordered as retrofit kit or together with the pump unit.

Advantages to the User

- Interface box for assembly on screw pump SCREWLINE SP 250 and SP 630
- Read out of vibration levels, oil temperatures, warning and failure functions
- The interface box is mounted next to the SP-GUARD
- Interface box needs a 24 V DC supply on-site (24 V DC supply of the SP-GUARD can be used)

Available Interfaces

- Profibus
- Wi-Fi

Further interfaces upon request:

- Profinet
- DeviceNet
- Ethernet
- CAN bus
- Interbus
- etc.

Ordering Information

Interface Kit SP-GUARD

	Part No.
Interface kit SP-GUARD Profibus	502 898 V001
Profibus kit and Wi-Fi with iPhone for SP-GUARD	503 264 V901
Profibus interface kit and Wi-Fi for SP-GUARD	503 183 V901
SCREWLINE SP 630 screw pump with Profibus interface	502 899 V001
Further combinations	upon request

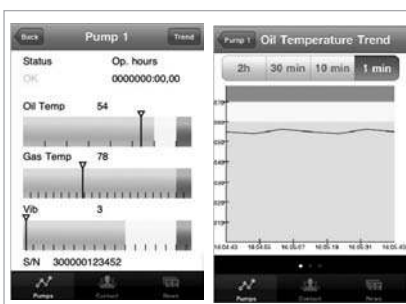

Various indications on the mobile equipment



Profibus interface kit for SP-GUARD



Smart phone / tablet PC for readout (Wi-Fi)

Miscellaneous to oil sealed and dry compressing Pump Systems

Checklist for Inquiries

To Leybold GmbH

Dept. Systems

Fax: +49 (0)221/347 - 31206

e-Mail:

vacuum.solutions@leybold.com

From company: _____

Name/Department: _____

Phone: _____ Date: _____

Fax: _____ First page of: _____

MAKE USE OF OUR KNOW-HOW !

Simply fax the completed checklist to us. Our engineers will design a pump system which exactly matches your requirements. You will receive an offer shortly.

1. In what kind of application will the pump system be used (e.g. drying, distillation)?

2. Is the process run
 continuously in batches:

3. What is the volume of the vacuum chamber?

_____ m³

4. What pump-down times are required/desired?

_____ min³ x h⁻¹

5. What operating pressures are planned?

_____ mbar

6. How high is the ambient temperature?

- when installed in the building:

min. _____ °C / max. _____ °C

- when installed out in the open

min. _____ °C / max. _____ °C

7. How high is the intake temperature?

_____ °C

8. What is the composition of the gas which is to be pumped.

Designation:

a) _____ b) _____

c) _____ d) _____

e) _____ f) _____

9. Quantity (kg/h or Nm³/h), traces (%):

a) _____ b) _____

c) _____ d) _____

e) _____ f) _____

10. In case of materials not commonly listed in the tables please state:

a) Molecular mass _____

b) Thermal capacity _____

c) Vapor pressure _____

d) Viscosity _____

e) Melting point _____

f) Special characteristics _____

11. Must explosion hazard regulations be observed?

yes no

if yes, which? _____

12. What kind of electrical supplies are available?

a) Voltage _____

b) Frequency _____

13. What kind of mechanical connection specifications are planned?

a) Length of the intake line _____

b) Diameter of the intake line _____

14. Which cooling media are available (water, brine, etc.)? Which temperature?

_____ min. _____ °C

_____ max. _____ °C