

Instruction Manual

SL2KW SERIES

High Voltage Power Supply

MODEL :
SERIAL# :
DATE :

**SPELLMAN
HIGH VOLTAGE ELECTRONICS
CORPORATION**

One Commerce Park
Valhalla, New York, 10595

+1(914) 686-3600* FAX: +1(914) 686-5424*

E-mail: sales@spellmanhv.com

Website: www.spellmanhv.com

IMPORTANT SAFETY PRECAUTIONS

SAFETY

THIS POWER SUPPLY GENERATES VOLTAGES THAT ARE DANGEROUS AND MAY BE FATAL.
OBSERVE EXTREME CAUTION WHEN WORKING WITH THIS EQUIPMENT.

High voltage power supplies must always be grounded.

Do not touch connections unless the equipment is off and the Capacitance of both the load and power supply is discharged.

Allow five minutes for discharge of internal capacitance of the power supply.

Do not ground yourself or work under wet or damp conditions.

SERVICING SAFETY

Maintenance may require removing the instrument cover with the power on.

Servicing should be done by qualified personnel aware of the electrical hazards.

WARNING note in the text call attention to hazards in operation of these units that could lead to possible injury or death.

CAUTION notes in the text indicate procedures to be followed to avoid possible damage to equipment.

Copyright © 2000, Spellman High Voltage Electronics Corporation. All Rights Reserved.
This information contained in this publication is derived in part from proprietary and patent data. This information has been prepared for the express purpose of assisting operating and maintenance personnel in the efficient use of the model described herein, and publication of this information does not convey any right to reproduce it or to use it for any purpose other than in connection with installation, operation, and maintenance of the equipment described.

WICHTIGE SICHERHEITSHINWEISE

SICHERHEIT

DIESES HOCHSPANNUNGSNETZTEIL ERZEUGT LEBENSGEFÄHRLICHE HOCHSPANNUNG.
SEIN SIE SEHR VORSICHTIG BEI DER ARBEIT MIT DIESEM GERÄT.

Das Hochspannungsnetzteil muß immer geerdet sein.

Berühren Sie die Stecker des Netzteiles nur, wenn das Gerät ausgeschaltet ist und die elektrischen Kapazitäten des Netzteiles und der angeschlossenen Last entladen sind.

Die internen Kapazitäten des Hochspannungsnetzteiles benötigen ca. 5 Minuten, um sich zu entladen.

Erden Sie sich nicht, und arbeiten Sie nicht in feuchter oder nasser Umgebung.

SERVICESICHERHEIT

Notwendige Reparaturen können es erforderlich machen, den Gehäusedeckel während des Betriebes zu entfernen.

Reparaturen dürfen nur von qualifiziertem, eingewiesenem Personal ausgeführt werden.

“WARNING” im folgenden Text weist auf gefährliche Operationen hin, die zu Verletzungen oder zum Tod führen können.

“CAUTION” im folgenden Text weist auf Prozeduren hin, die genauestens befolgt werden müssen, um eventuelle Beschädigungen des Gerätes zu vermeiden.

PRECAUTIONS IMPORTANTES POUR VOTRE SECURITE

CONSIGNES DE SÉCURITÉ

CETTE ALIMENTATION GÉNÈRE DES TENSIONS QUI SONT DANGEUREUSES ET PEUVENT ÊTRE FATALES.
SOYEZ EXTRÊMEMENT VIGILANTS LORSQUE VOUS UTILISEZ CET ÉQUIPEMENT.

Les alimentations haute tension doivent toujours être mises à la masse.

Ne touchez pas les connectiques sans que l'équipement soit éteint et que la capacité à la fois de la charge et de l'alimentation soient déchargées.

Prévoyez 5 minutes pour la décharge de la capacité interne de l'alimentation.

Ne vous mettez pas à la masse, ou ne travaillez pas sous conditions mouillées ou humides.

CONSIGNES DE SÉCURITÉ EN CAS DE REPARATION

La maintenance peut nécessiter l'enlèvement du couvercle lorsque l'alimentation est encore allumée.

Les réparations doivent être effectuées par une personne qualifiée et connaissant les risques électriques.

Dans le manuel, les notes marquées « **WARNING** » attire l'attention sur les risques lors de la manipulation de ces équipements, qui peuvent entraîner de possibles blessures voire la mort.

Dans le manuel, les notes marquées « **CAUTION** » indiquent les procédures qui doivent être suivies afin d'éviter d'éventuels dommages sur l'équipement.

IMPORTANTI PRECAUZIONI DI SICUREZZA

SICUREZZA

QUESTO ALIMENTATORE GENERA TENSIONI CHE SONO PERICOLOSE E POTREBBERO ESSERE MORTALI.
PONI ESTREMA CAUTELA QUANDO OPERI CON QUESTO APPARECCHIO.

- Gli alimentatori ad alta tensione devono sempre essere collegati ad un impianto di terra.
- Non toccare le connessioni a meno che l'apparecchio sia stato spento e la capacità interna del carico e dell'alimentatore stesso siano scariche.
- Attendere cinque minuti per permettere la scarica della capacità interna dell'alimentatore ad alta tensione.
- Non mettere a terra il proprio corpo oppure operare in ambienti bagnati o saturi d'umidità.

SICUREZZA NELLA MANUTENZIONE.

- Manutenzione potrebbe essere richiesta, rimuovendo la copertura con apparecchio acceso.
- La manutenzione deve essere svolta da personale qualificato, coscio dei rischi elettrici.
- Attenzione alle **AVVERTENZE** contenute nel manuale, che richiamano all'attenzione ai rischi quando si opera con tali unità e che potrebbero causare possibili ferite o morte.
- Le note di **CAUTELA** contenute nel manuale, indicano le procedure da seguire per evitare possibili danni all'apparecchio.

Table of Contents

	PAGE
1. INTRODUCTION	
1.1 Description of the SL2KW Series	1
1.2 Standard Features	2
1.2.1 Remote Operating Features	2
1.2.2 System Status and Fault Diagnostic Display	2
1.3 Options.....	3
1.4 Interpreting the Model Number.....	4
2. INSPECTION & INSTALLATION	
2.1 Initial Inspection.....	5
2.2 Mechanical Installation.....	5
3. OPERATING INSTRUCTIONS	
3.1 Operation.....	7
3.2 Standard Features	8
4. PRINCIPLES OF OPERATION	
4.1 Chassis	17
4.2 Line Rectification and Filtering	17
4.3 Inverter.....	18
4.4 High Voltage Transformer.....	18
4.5 High Voltage Assembly.....	18
4.6 Control/Power PWB.....	19
4.7 Front Panel Assembly.....	19
4.8 Options.....	19
5. OPTIONS	
5.1 Adjustable Overload Trip	20
5.2 Adjustable Power Trip.....	20
5.3 Arc Sense	20
5.4 Arc Trip.....	20
5.5 Current Mode Select.....	20
5.6 Constant Power Control.....	20
5.7 Digital Panel Meter, 4.5 Digits.....	20
5.8 External Fault Relay	21

5.9	Fine Control Voltage	21
5.10	Instant On.....	21
5.11	Lead Length	21
5.12	No Arc Detect.....	21
5.13	No Slow Start	21
5.14	Positive/Negative.....	21
5.15	Remote Fault Reset.....	21
5.16	Remote Over Voltage	22
5.17	Slides.....	22
5.18	Slow Start.....	22
5.19	Custom Design Models.....	22
6.	MAINTENANCE	
6.1	Periodic Servicing	24
6.2	Performance Test.....	24
6.3	High Voltage Dividers.....	24
7.	REPLACEMENT PARTS	
7.1	Replacement Parts	25
7.2	Correspondence and Ordering Spare Parts	25
8.	FACTORY SERVICE	
8.1	Warranty Repairs.....	26
8.2	Factory Service Procedures.....	26
8.3	Ordering Options and Modifications	26
8.4	Shipping Instructions.....	26

LIST OF FIGURES

Figure 2.1	SL Series Dimensions	6
Figure 3.1	SL Series Typical Operating Set Up.....	10
Figure 3.2A	Wiring Diagram for Remote Programming via Voltage Source	12
Figure 3.2B	Wiring Diagram for Remote Programming via External Resistance	12
Figure 3.3	Remote Monitor Test Point Designations	13
Figure 3.4	Remote Control of High Voltage On and Off	13
Figure 3.5	External Inhibit Interface Circuit.....	14
Figure 3.6	External Interlock Interface Circuit	14
Figure 3.7	Remote High Voltage On and Remote High Voltage off Indicator Circuit....	15
Figure 3.8	Remote Indicators Interface	16
Figure 5.1	Polarity Reversal Procedures, 1kV to 8kV	22
Figure 5.2	Polarity Reversal Procedures 10kV to 50kV	22
Figure 5.3	Instant On Option.....	23

LIST OF TABLES

Table 1.1	SL2KW Options	3
Table 3.1	Rear Panel Interface 25 pin Mini D.....	11
Table 4.1	List of Main Assemblies	18

APPENDIX

A. Specification Controls (Custom Models Only)

Chapter 1

INTRODUCTION

1.1 Description of The SL2KW Series

The SL2KW Series of high voltage power supplies provides very well regulated, low ripple high voltage in a highly efficient, compact design. The improvements in size and performance over traditionally designed high voltage power supplies are due to the resonant topology and unique control circuitry of the SL2KW design. A proprietary control system maintains high frequency over the operating output range. The combination of proprietary control system and proprietary protection circuitry enables the supplies to operate under arcing and extreme transient conditions without damage or interruptions.

The DC output voltage and current are continuously adjustable from zero to the maximum rating via two front panel ten-turn locking potentiometers.

Custom designed units to meet special needs are also available.

1.2 Standard Features

The SL2KW Series incorporates several standard features designed to optimize user satisfaction and safety.

- **SLOW START:** This feature provides a gradual increase in high voltage until the preset operating point is reached. The slow start time is factory set for 6 seconds. Other slow start times are available as an option.
- **ARC DETECT / ARC QUENCH / ARC COUNT:** These features allow the user to tailor the power supply to meet specific needs in dynamic load applications. If an arc occurs, the output is inhibited for approximately 0.5 second, then the output is ramped up to the preset level with the slow-start circuitry. See Chapter 3 for operating details and information for user customization of these features.
- **INTERNAL FAULT PROTECTION:** The SL Series continually monitors internal circuits critical to the proper operation of the power supply. In the event that one of these circuits does not function correctly, the fault detection circuit latches the appropriate fault on the front panel display and turns off the output and reverts the unit to the POWER DOWN mode.
- **INDICATOR LAMPS:** LINE POWER, HIGH VOLTAGE OFF AND HIGH VOLTAGE ON indicators.
- **OUTPUT CABLE:** All models are provided with a ten foot shielded high voltage output cable. The cables are designed with a plug arrangement so that they can be easily removed from the mating receptacle located on the rear of the chassis.

1.2.1 Remote Operating Features

- **REMOTE PROGRAMMING:** Allows remote adjustment of the output voltage and current via an external voltage source.
- **REMOTE MONITOR:** Allows remote monitoring of the output voltage and current.
- **REMOTE HIGH VOLTAGE CONTROL:** Allows remote control of HIGH VOLTAGE ON and HIGH VOLTAGE OFF. Signals are also provided for remote indication of HV ON or HV OFF status.

- **EXTERNAL INHIBIT:** A control signal that will inhibit the high voltage output is provided on the external interface. A logic low, ground, will inhibit the high voltage output and a logic high, open, will restore the high voltage output to the preset level.

NOTE: The External Inhibit circuit should NOT be used for protection against injury or for safety interlock. See External Interlock for this type of safety control.

- **EXTERNAL INTERLOCK:** Interlock connections are provided on the external interface on the rear of the chassis for connection to a safety switch. The unit will not operate unless the interlock circuit is closed. During high voltage operation, opening the interlock circuit will cause the High Voltage to shut off. This circuit should be used for safety interlock circuits.

1.2.2 System Status and Fault Diagnostic Display

“Dead Front” type indicators are provided to give the user complete indication of system operation and fault conditions. If a fault occurs, the power supply will revert to the POWER DOWN mode. This is indicated by both the HV ON and HV OFF lamps turning off. To reset, depress the HV OFF switch.

- **VOLTAGE (CONTROL):** Indicates the output voltage regulator circuit is maintaining voltage regulation.
- **CURRENT (CONTROL):** Indicates the output current regulator circuit is maintaining current regulation.
- **HV INHIBIT:** Indicates that the high voltage supply is being inhibited by either the EXTERNAL INHIBIT or internal protection circuitry.
- **INTLK CLSD:** Indicates the EXTERNAL INTERLOCK connections are in the closed position. This also indicates closure of internal power supply interlocks.

- **INTKL OPEN:** Indicates the EXTERNAL INTERLOCK connections are in the open position. This also indicates opening of internal power supply interlocks.
- **OVERVOLT:** Indicates the overvoltage protection circuitry has caused the power supply to turn off. Overvoltage protection is internally set to 110% of the rated output voltage.
- **OVERCURR:** Indicates the output current has exceeded the programmed current trip level when the AOL (Adjustable Overload Trip) or the OL (Overload Trip) options are installed.
- **ARC:** Indicates that an arc has occurred within the previous one second or that the ARC COUNT/TRIP has shutdown the power supply.
- **RGLT ERR:** Indicates a failure in the voltage, current or power regulation circuitry. This fault usually occurs when there is a lack of output power to maintain regulation.

The options available are listed in Table 1.1. See Section 5 for more information on these options along with operating and set-up instructions. With few exceptions, these options and modifications can be retrofitted to your power supply at the factory in a short time. For price and retrofit arrangements, contact the Spellman Sales Department.

1.3 Options

AOL	Adjustable Overload Trip (0-103%)
APT	Adjustable Power Trip
ARC	Arc Sense
AT	Arc Trip
BPM/BPS	Bipolar Master/Slave
CMS	Current Mode Select
CPC	Constant Power Control
DPM4	Digital Panel Meter
EFR	External Fault Relay
FCV	Fine Control Voltage
IO	Instant On
SL	Slides
LL(X)	Lead Length
NAD	No Arc Detect
NSS	No Slow Start
PN	Positive/Negative
RFR	Remote Fault Reset
ROV	Remote Over Voltage
SL	Slides
SS(X)	Slow Start (X)

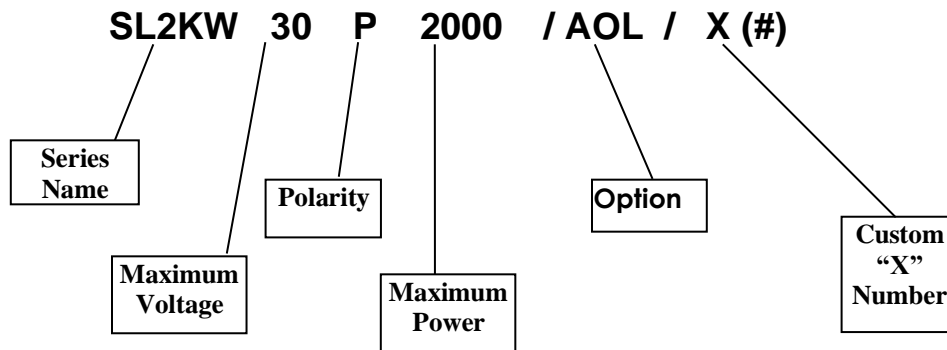
Table 1.1 SL2KW Options

1.4 Interpreting the Model Number

The model number of the power supply describes its capabilities. After the series name is:

1. the maximum voltage (in KV).
2. the polarity of the unit: positive (P), negative (N) or reversible (PN).
3. the maximum output (in watts).
4. the option codes for all options that are included.

Custom units have an X number after the option codes.



Chapter 2

INSPECTION & INSTALLATION

Initial inspection and preliminary checkout procedures are recommended. For safe operation, please follow the step-by-step procedures described in Chapter 3, Operating Systems.

2.1 Initial Inspection

Inspect the package exterior for evidence of damage due to handling in transit. Notify the carrier and Spellman immediately if damage is evident. Do not destroy or remove any of the packing material used in a damaged shipment.

After unpacking, inspect the panel and chassis for visible damage.

Fill out and mail the Warranty Registration card accompanying the unit. Standard Spellman SL Series high voltage power supplies and components are covered by warranty. Custom and special order models (with an X suffix and the model number) are also covered by warranty.

2.2 Mechanical Installation

Units in the SL2KW Series have front panel holes for standard EIA rack mounting. The rack must allow rear access for cable connections. Units are fully enclosed and are suitable for bench or table top operation. Standard unit dimensions are shown in Figure 2.1. It is strongly recommended to support the chassis by guides or slides. Slides are available for ease of servicing (SL option).

25 PIN D CONNECTOR

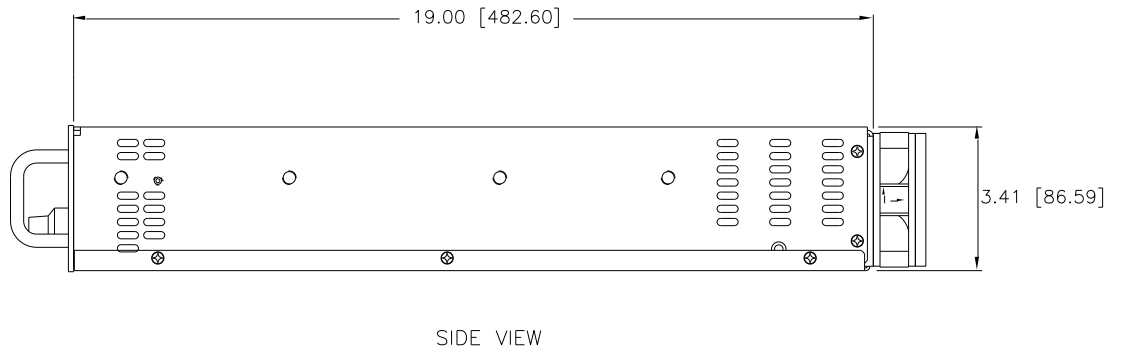
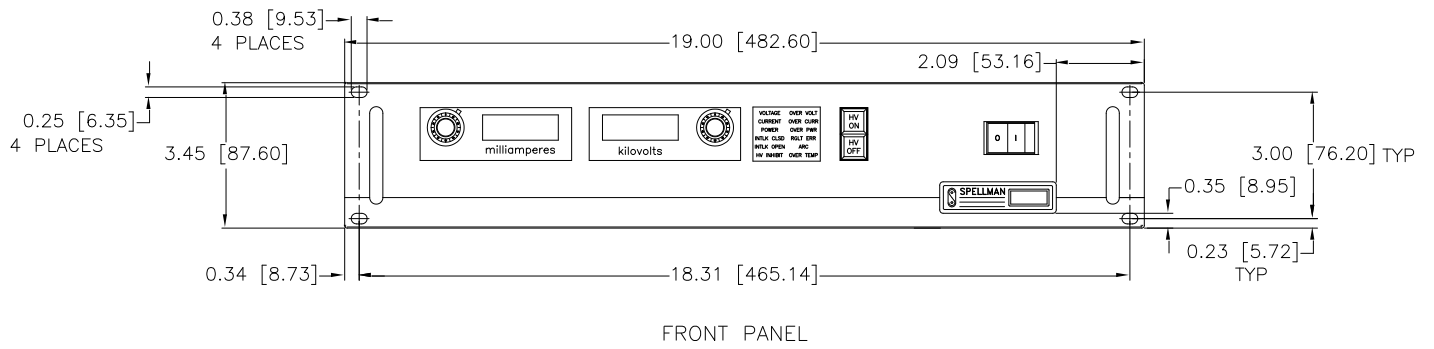
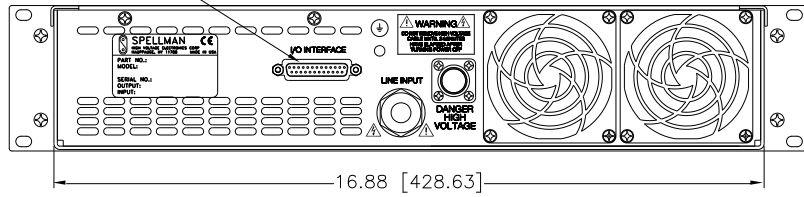


Figure 2.1- SL2KW Dimensions

Chapter 3

OPERATING INSTRUCTIONS

3.1 Operation

WARNING

THIS EQUIPMENT GENERATES DANGEROUS VOLTAGES THAT MAY BE FATAL.

PROPER GROUNDING OF ALL HIGH VOLTAGE EQUIPMENT IS ESSENTIAL.

WARNING

BEFORE CONNECTING THE POWER SUPPLY TO THE AC LINE, FOLLOW THIS STEP BY STEP PROCEDURE.

DO NOT CONNECT THE POWER SUPPLY TO THE AC LINE UNTIL STEP H IS REACHED.

Failure to follow these procedures may void the warranty.

- A) Insure that the Circuit Breaker is in the OFF position (0).
- B) Check the input voltage rating on the nameplate of the supply and make certain that this is the rating of the available power source. Spellman SL2KW Series units operate on 208Vac Three Phase (220Vac Single Phase if 220Vac Single Phase is ordered).
- C) **PROPER GROUNDING TECHNIQUES:** The chassis of high voltage power supplies must be grounded, preferably to a water system ground using copper pipe or other earth ground using the ground stud B1 at the rear of the unit. See Figure 3.1 for a typical operating set-up.

The return line from the load should be connected to the ground stud, on the rear of the power supply. Using a separate external ground at the load is not recommended.

- D) Attach the output cable to the load.

- E) Plug the high-voltage output cable provided with the unit into the rear of the supply and hand tighten the knurled collar.
- F) **OPTIONS NOTE:** See Section 5 for hook-up and operating instructions for the options on your unit. Custom models may also require set-up changes.
- G) For initial turn-on, rotate the KILOVOLT control fully counter-clockwise to the zero voltage position.
- H) The input power cable may now be connected to the AC power line.
- I) Switch the front panel circuit breaker to the ON position (1). (If the supply is to be turned off for an extensive period of time, the line cord should be disconnected). The unit is now in the HIGH VOLTAGE OFF mode. The HIGH VOLTAGE OFF light should be lit.
- J) Depress and hold the HIGH VOLTAGE OFF switch. The front panel meters will now read the preset value of the KILOVOLT control dial and the MILLIAMPERES control dial. To preset the desired level of current and voltage during operation, hold in the HIGH VOLTAGE OFF switch and rotate the appropriate control dial while noting its corresponding meter reading. Release the HIGH VOLTAGE OFF switch.

NOTE: No actual output is being produced at this stage.

- K) Depress the HIGH VOLTAGE ON switch. The light inside the switch should light up and the output will slow start to the preset level output voltage and/or output current.

NOTE: The SL2KW Series is equipped with a slow start circuit that ramps the output up to its maximum setting in approximately 6 seconds after the HIGH VOLTAGE ON switch is depressed.

- L) To terminate the generation of output power, depress the HIGH VOLTAGE OFF switch. In the HIGH VOLTAGE OFF mode the power supply's fault and interface circuits are still active.

M) To turn off the power supply, turn the circuit breaker to the off position (0).

NOTE: If a power supply fault, or system monitoring fault occurs, the power supply will revert to the POWER DOWN mode. In this mode the output power will be turned off. The HV OFF lamp will be off. To reset, depress the HV OFF switch.

WARNING

AFTER TURNOFF, DO NOT HANDLE THE LOAD UNTIL THE CAPACITANCE HAS BEEN DISCHARGED!

LOAD CAPACITANCE MAY BE DISCHARGED BY SHORTING TO GROUND.

WARNING

THE VOLTMETER ON THE POWER SUPPLY FRONT PANEL DOES NOT READ THE OUTPUT VOLTAGE WHEN THE POWER IS TURNED OFF, EVEN IF A CHARGE STILL EXISTS ON THE LOAD.

CAUTION

ALWAYS OPERATE THE UNIT WITH THE COVER ON.

A fan maintains safe operating temperature in the power supply by drawing air over the circuit components. The cover must be on in order to direct the air flow over the areas that need cooling. In operation, the unit must be placed so that the air intake and the fan exhaust are clear of obstructions that might impede the flow of air.

3.2 Standard Features

A note on remote interface circuitry and remote signal grounding. Whenever possible, electrical isolation should be provided when interfacing with any high voltage power supply. For power control signals such as EXTERNAL INTERLOCK, HIGH VOLTAGE OFF, AND HIGH VOLTAGE ON, isolated relay contacts should be used. For status signals and control signals such as HIGH VOLTAGE ON, HIGH VOLTAGE OFF, and EXTERNAL INHIBIT, etc., opto-isolation should be used. If possible, analog programming and monitoring signals should be isolated via analog isolation amplifiers. Spellman application engineers are available to assist in interface circuitry design. All interface cables should be properly shielded. All power supply signals should be

referenced to the power supplies signal ground on the rear external interface.

- **REMOTE PROGRAMMING:** Allows remote adjustment of the output voltage and current via an external voltage source. In local control (front panel control), jumpers are installed on the external interface J5 in the rear of the chassis between J5-10 and J5-11 for voltage control and between J5-8 and J5-9 for current control.

For remote programming, the jumpers are removed and a positive voltage source, from 0V to 10V, is applied to the appropriate terminals. Programming signals should be referenced to J5-1, signal ground. By adjusting the voltage source from 0V (zero output) to 10V (full rated output), the desired output can be selected. See Figure 3.2A for the wiring diagram and specifications.

An alternate method of controlling the output remotely is by using external resistance, such as a potentiometer or a resistor network. For remote control the jumpers are removed and the desired register configuration installed. See Figure 3.2B for the wiring diagram.

- **REMOTE MONITOR:** Test points are made available at the 25 pin D connector on the rear of the chassis for monitoring the voltage and current output. The test points are always positive regardless of the output polarity where 0V to 10V equals 0 to 100% of the output $\pm 0.5\%$. Test points have an output impedance of 5K ohms. See Figure 3.3 for the test point designation.
- **REMOTE CONTROL:** Remote control of the HIGH VOLTAGE ON and HIGH VOLTAGE OFF can be accomplished via the rear panel interface. HIGH VOLTAGE OFF and HIGH VOLTAGE ON can be controlled by momentary normally closed and normally open contacts respectively. See Figure 3.4 on page 14 for the recommended interface.
- **EXTERNAL INHIBIT:** Allows the user to inhibit the power supply output without switching HIGH VOLTAGE OFF control. This circuit can be used to generate fast slewing output waveforms or control of high voltage generation as in Laser and Capacitor discharge applications. The maximum inhibit rate should not exceed 5Hz. Consult the factory for higher repetition rates or high pulse load applications. See Figure 3.5 for the recommended interface circuit.

WARNING

IT IS EXTREMELY DANGEROUS TO USE THIS INHIBIT CIRCUIT TO INHIBIT HIGH VOLTAGE GENERATION FOR THE PURPOSE OF SERVICING OR APPROACHING ANY AREA OR LOAD CONSIDERED UNSAFE DURING NORMAL USE.

- **EXTERNAL INTERLOCK:** Interlock connections are provided on the terminal block J5-3 and J5-4 on the rear of the chassis for connection to a safety switch. The unit will not operate unless the interlock circuit is closed. If the interlock is not being used, the jumper installed on the terminals before shipping must be in place. If the jumper is missing, or there is an opening between the interlock terminals, the unit's high voltage inverter will be disabled. During high voltage operation, revert to the HIGH VOLTAGE OFF mode. Subsequent closing of the interlock circuit will NOT return the unit to the HIGH VOLTAGE ON mode. This must be accomplished by depressing the HIGH VOLTAGE ON switch. See Figure 3.6 for the recommended interface circuit
- **ARC DETECT / ARC QUENCH / ARC COUNT:** The ARC DETECT circuit senses dynamic arcing or discharge conditions present at the output load. If an arc occurs, the output is inhibited for .5 seconds.

After the .5 second period, the output is ramped up to the previous set level. This ramp is based on the standard six second slow start feature. The ARC DETECT ramp circuit may be disabled by removing CR32 on the Control/Power Pwb. Caution should be observed if this feature is disabled. Discharge rates of greater than 1Hz may cause excessive power dissipation in the power supply's output limiting resistors.

The ARC COUNT feature will allow the user to program the ARC fault parameters. The ARC indicator on the front panel will illuminate for approximately one second after each arc has occurred. The power supply can be programmed to trip the POWER DOWN mode if an arc occurs.

The standard feature is programmed to trip the power supply if 8 arcs occur within a twenty second period.

- **REMOTE HIGH VOLTAGE ON & REMOTE HIGH VOLTAGE OFF:** Signals are provided for remote monitoring of the HIGH VOLTAGE ON/OFF status. See Figure 3.7 for recommended interface.
- **REMOTE MODE INDICATORS:** Signals are provided for remote indication of the control mode status, voltage control, current control, and power control. See Figure 3.8 for the recommended interface.

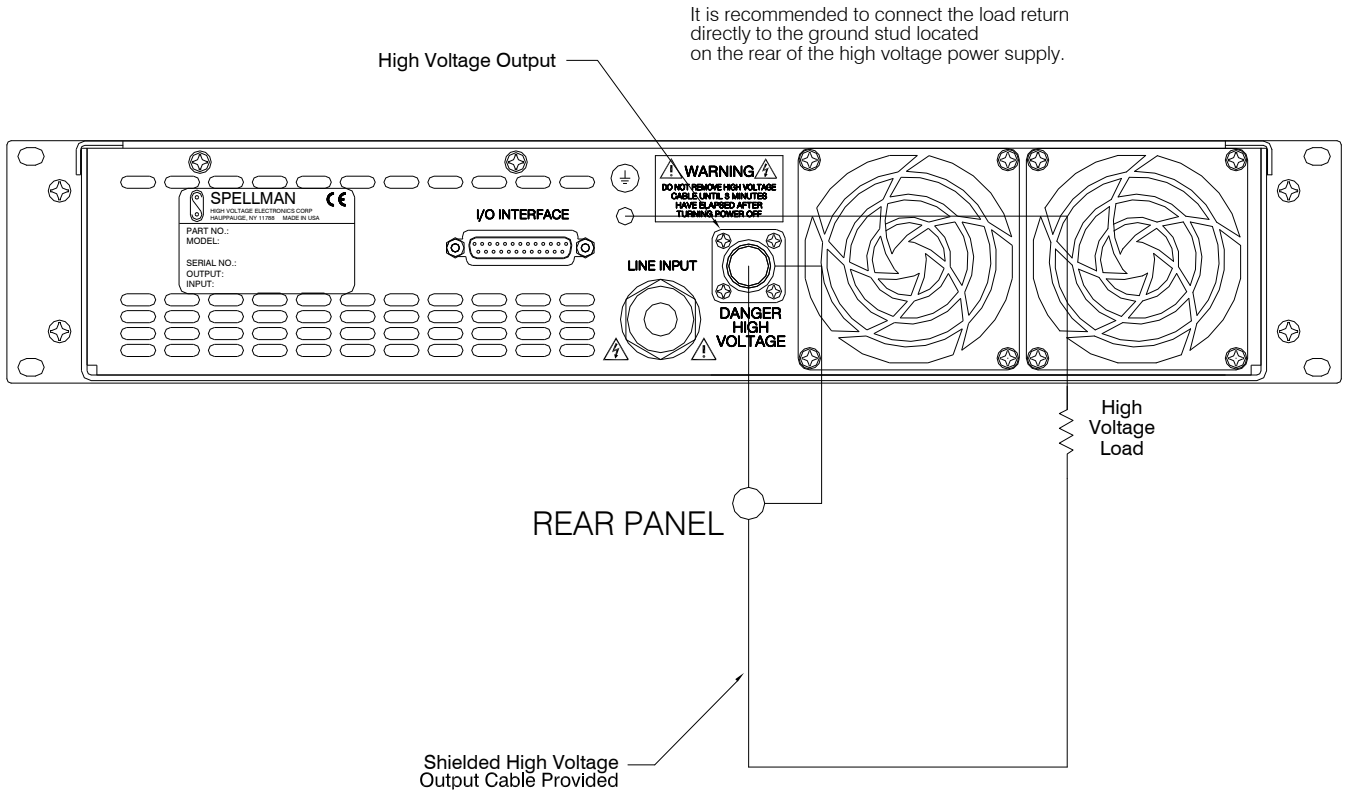


Figure 3.1- Typical Operating Setup





	J5	SIGNAL	SIGNAL PARAMETERS
	1	Power Supply Common	Signal Ground
	2	External Inhibit	Ground = Inhibit, Open = HV ON
	3	External Interlock	+15V at Open, <15mA at Closed
	4	External Interlock Return	Return For Interlock
	5	Current Monitor	0 to 10V = 0 to 100% Rated Output
	6	kV Test Point	0 to 10V = 0 to 100% Rated Output
	7	+10V Reference	+10V, 1mA Max
	8	Remote Current Program In	0 to 10V = 0 to 100% Rated Output
	9	Local Current Program Out	Front Panel Program Voltage
	10	Remote Voltage Program In	0 to 10V = 0 to 100% Rated Output
	11	Local Voltage Program Out	Front Panel Program Voltage
	12	EFR (Common)	Optional External Fault Relay
	13	EFR (Normally Open / Closed)	
	14	Local HV Off Out	+15V at Open, < 25mA at Closed. Connect to HV OFF For FP Operation
	15	HV OFF	
	16	Remote HV ON	
	17	Remote HV OFF Indicator	0 = HV ON, +15V, 10mA Max = HV OFF
	18	Remote HV ON Indicator	0 = HV OFF, +15V, 10mA Max = HV ON
	19	Remote Voltage Mode	Open Collector 50V Max, 10mA Max On = Active
	20	Remote Current Mode	Open Collector 50V Max, 10mA Max On = Active
	21	Remote Power Mode	Open Collector 50V Max, 10mA Max On = Active
	22	Remote PS Fault	0 = Fault, +15V, 0.1 mA Max = No Fault
	23	+15V Output	+15V, 100mA Max
	24	Power Supply Common	Signal Ground
	25	Shield Return	Chassis Ground

Table 3.1 - Rear Panel Interface 25 pin Mini D

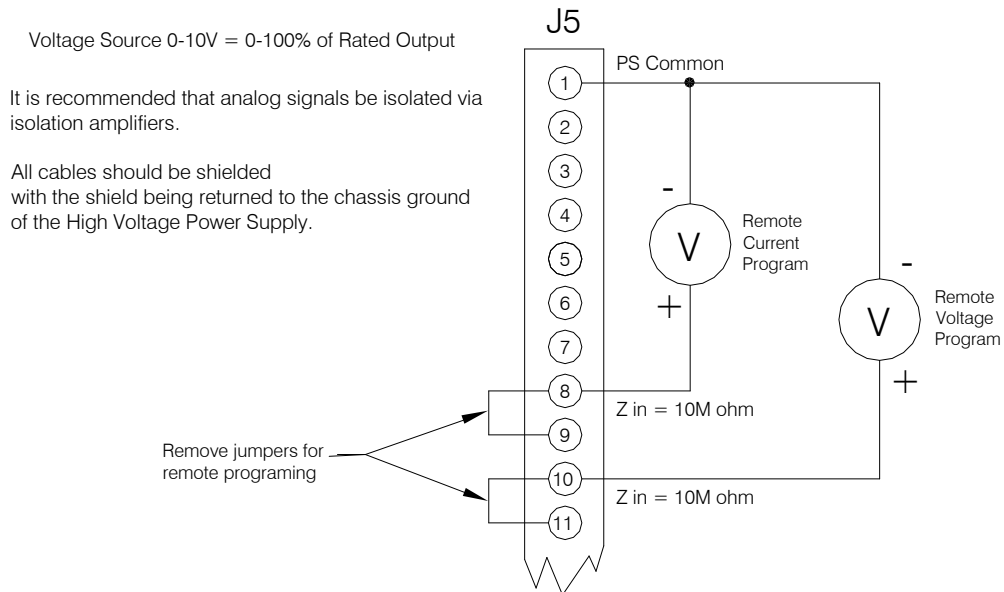


Figure 3.2A – Wiring Diagram for Remote Programming via Voltage

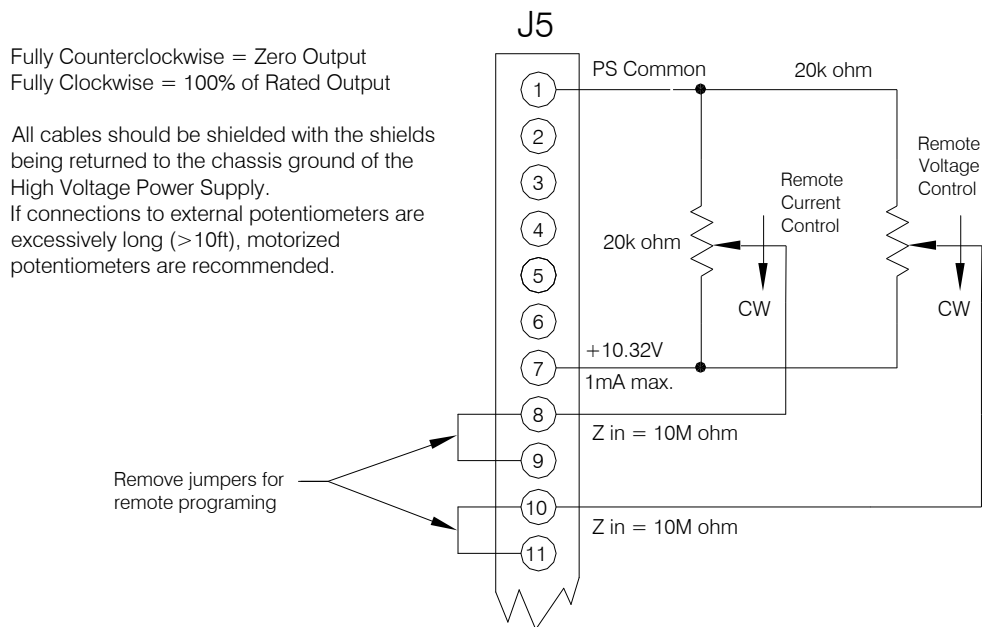


Figure 3.2B – Wiring Diagram for Remote Programming via External

It is recommended that analog signals be isolated via isolation amplifiers.

All cables should be shielded with the shield being returned to the chassis ground of the high voltage power supply.

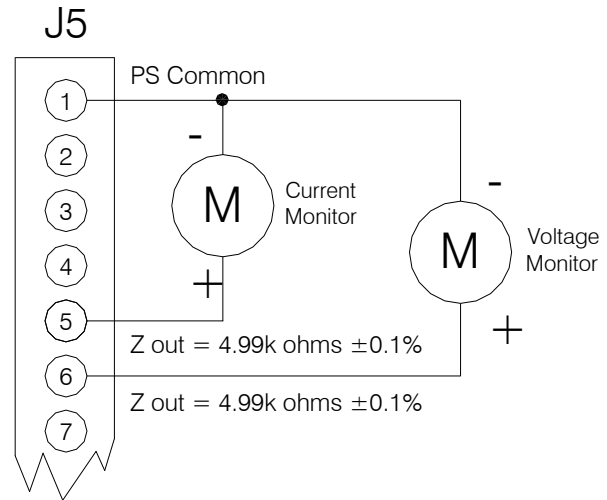


Figure 3.3 – Remote Monitor Test Point Designations

S1 must be closed to enable HIGH VOLTAGE.

Momentary closure of S2 will enable HIGH VOLTAGE ON.

Opening S1 will disable HIGH VOLTAGE ON and switch the unit to the HIGH VOLTAGE OFF mode.

It is recommended to use relay contacts for S1 and S2. Relays should be located as close as possible to the high voltage power supply. Coils should be driven from isolated sources. Signals are at 15Vdc, 25mA max., and are only to be used for contact closure.

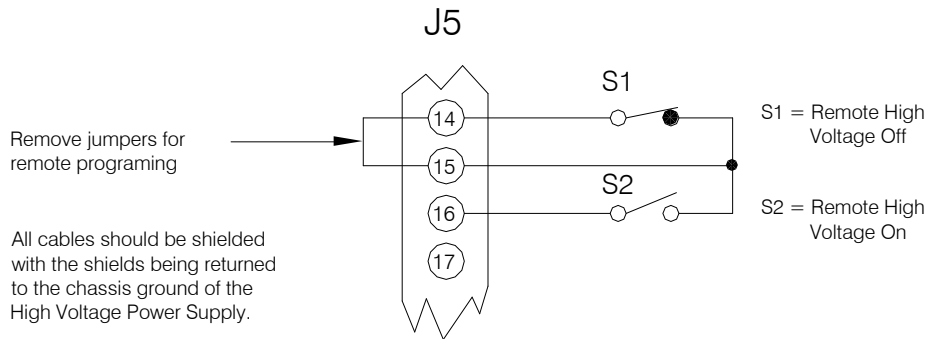


Figure 3.4 – Remote Control of High Voltage ON and High Voltage OFF Interface

The transistor should be located as close as possible to the power supply
 All cables should be shielded with the shields being returned to the chassis ground of the High Voltage Power Supply.

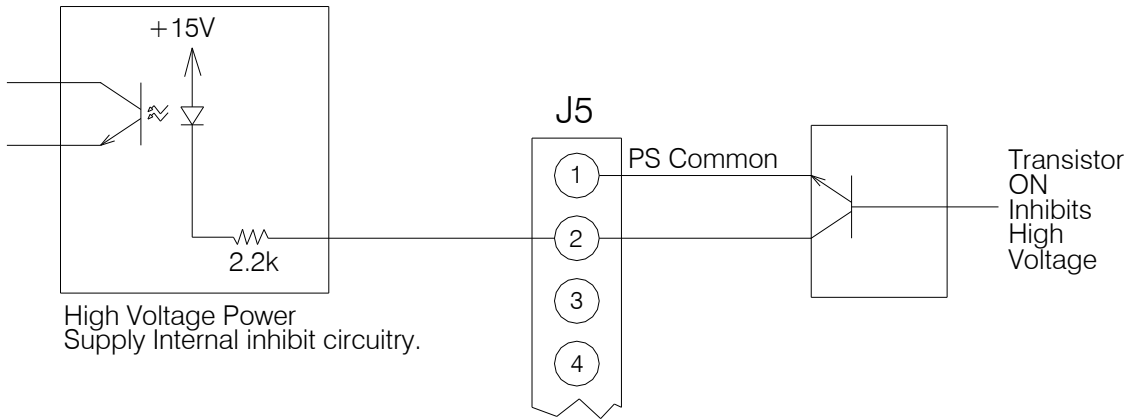
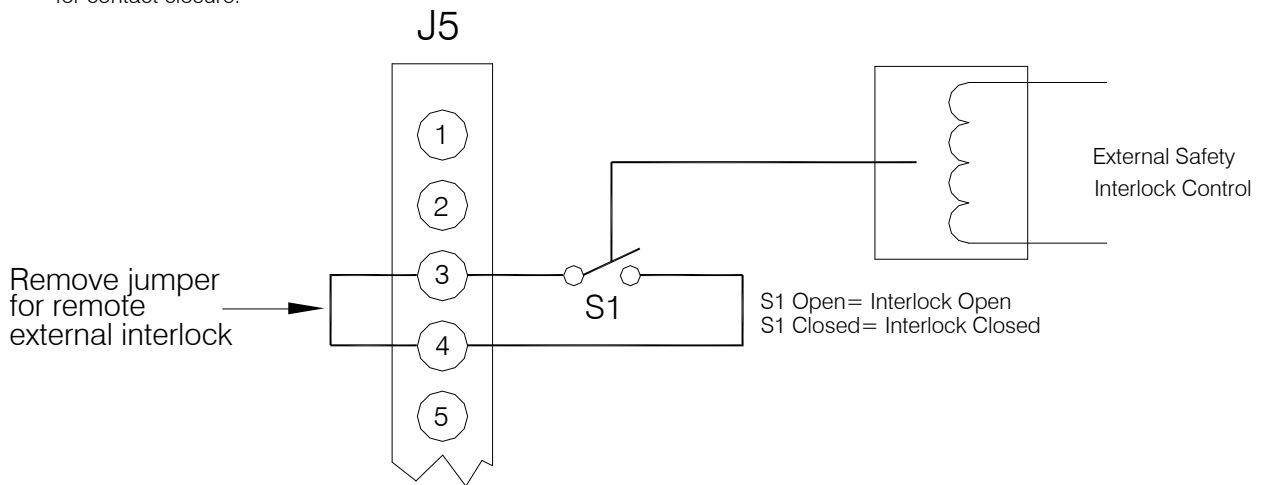


Figure 3.5 – External Inhibit Interface Circuit

Relay contacts are recommended for S1. The relay should be located as close as possible to the power supply.
 Signals are at 15Vdc, 25mA max and are only to be used for contact closure.



All cables should be shielded with the shields being returned to the chassis ground of the High Voltage Power Supply.

Figure 3.6 – External Interlock Interface

12Vdc lamps or relay coils may replace opto-couplers.
 Opto-couplers, lamps or relays should be located as close
 as possible to the high voltage power supply.
 All cables should be shielded with the shields being returned
 to the chassis ground of the High Voltage Power Supply.

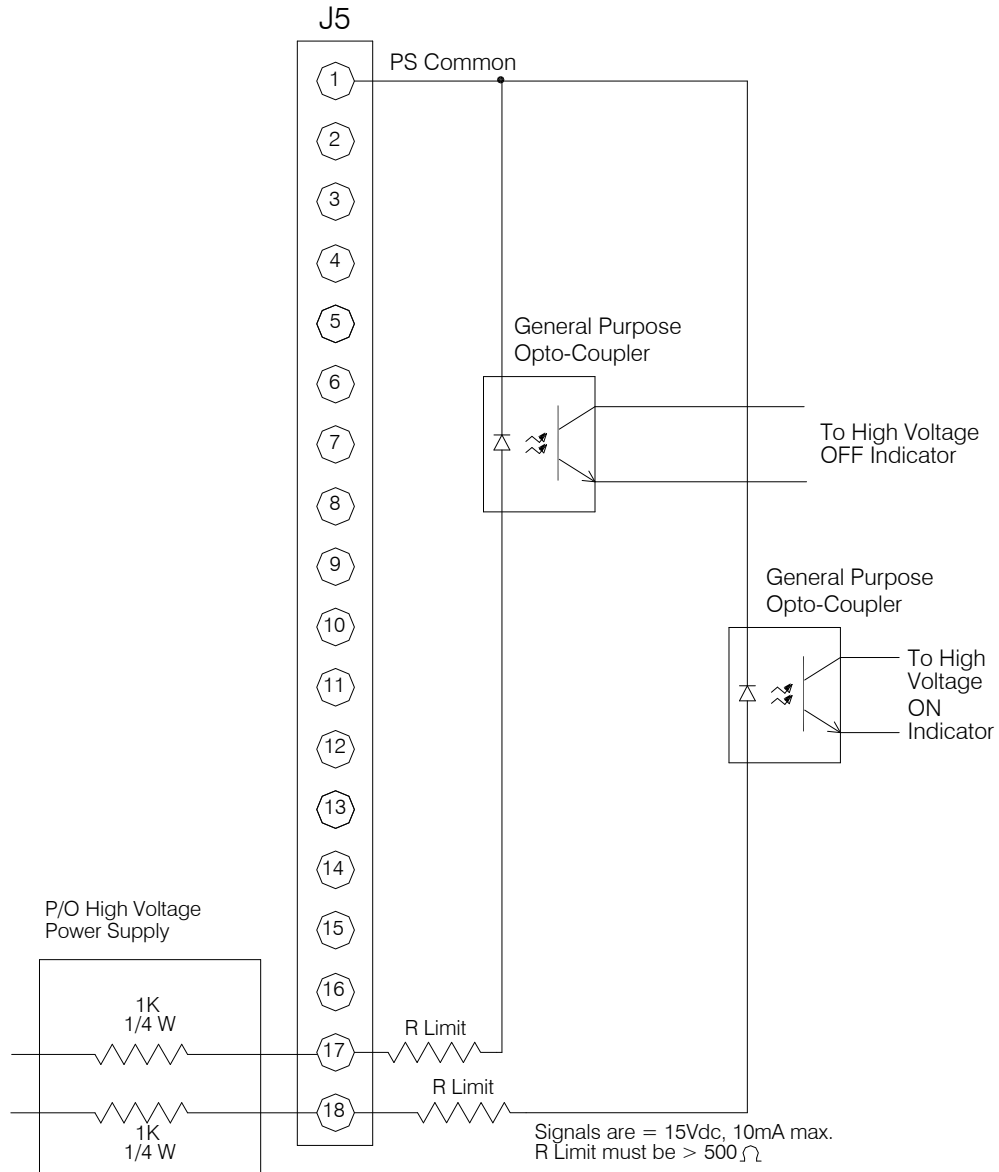


Figure 3.7 – Remote High Voltage ON and Remote High Voltage OFF Indicator

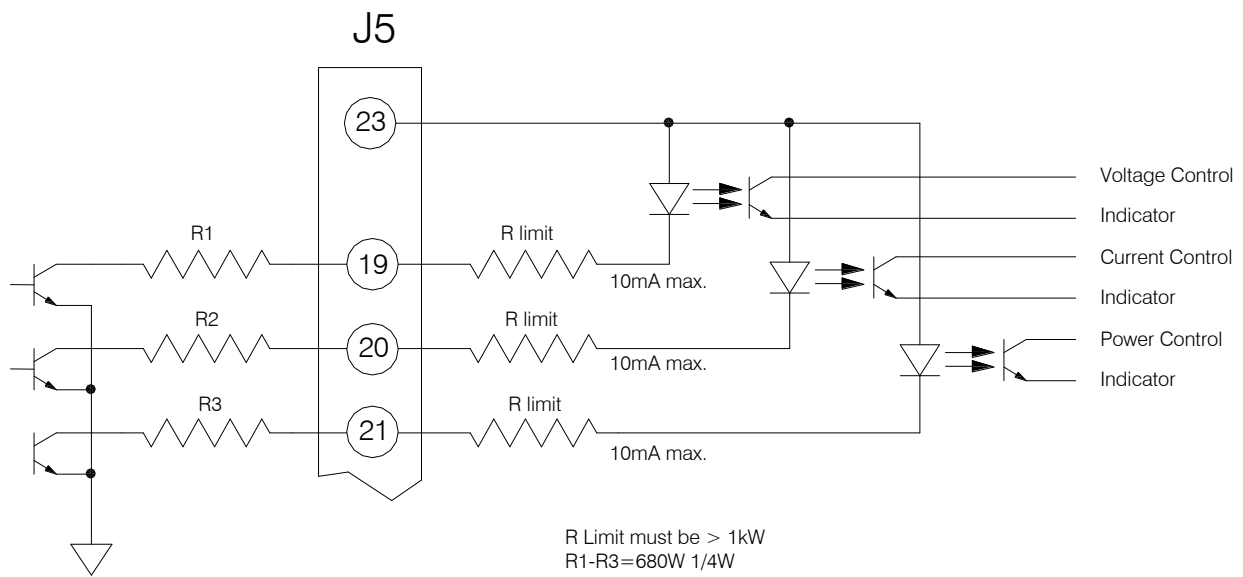


Figure 3.8 – Remote Mode Indicators Interface

Chapter 4

PRINCIPLES OF OPERATION

The SL2KW Series of high voltage power supplies utilizes sophisticated power conversion technology. A variety of analog, digital and power conversion techniques are used throughout. The intention of the Principles of Operation is to introduce the basic function blocks that comprise the SL2KW power supply. For details on a specific circuit, consult Spellman's Engineering Department.

See Table 4.1 for a list of the main assemblies found in a typical SL2KW power supply.

- Due to the many variations within the SL2KW Series, drawing numbers may differ from unit to unit.

The SL2KW power supply is basically an AC to DC power converter. Within the power supply, conversions of AC to DC then to high frequency AC, then to high voltage DC take place. By reviewing further the sub-assemblies, a basic understanding of the process can be gained.

4.1 Chassis

The SL2KW is a compact, high efficiency, high voltage power supply. The power supply can supply up to 2000

watts of DC power. Output voltages of up to 50kV can be generated.

WARNING

The energy levels used and generated by the power supply can be lethal! Do not attempt to operate the power supply unless the user has a sufficient knowledge of the dangers and hazards of working with high voltage. Do not attempt to approach or touch any internal or external circuits or components that are connected or have been connected to the power supply. Be certain to discharge any stored energy that may be present before and after the power supply is used. Consult IEEE recommended practices for safety in high voltage testing #510-1983.

4.2 Line Rectification And Filtering

Basic single phase rectification provides the DC voltage for the high frequency inverter.

ASSEMBLY TITLE	ASSEMBLY DRAWING NO.	SCHEMATIC DRAWING NO.
	J5	J5
SL Chassis (2000W)	403920-003	
Control / Power PWB (2000W)	404581-001	440687-001
High Voltage Assy (2000W)	403931-TAB	440534-001
Front Panel PWB	403895-001	440525-001

Table 4.1-List of Main Assemblies

In general, the following variations can be ordered:

- 208Vac \pm 10%, 50 to 60Hz, three phase.
- 220Vac \pm 10%, 50 to 60Hz, single phase.

If the user is unsure of which input voltage option is supplied, check the serial tag on the rear of the power supply or consult Spellman's Sales Department.

Circuit protection is provided by a front panel circuit breaker. The circuit breaker is a fast acting magnetic trip type circuit breaker. The line input is connected directly to the line side of the circuit breaker whereas the load side is connected to the CONTROL/POWER PWB. The load side of the breaker is also connected to a step-down type line transformer. This transformer provides voltage for housekeeping and control circuit power.

WARNING

LINE VOLTAGE IS PRESENT WHENEVER THE POWER SUPPLY IS CONNECTED TO EXTERNAL LINE VOLTAGES. BE SURE TO DISCONNECT THE LINE CORD BEFORE OPENING THE UNIT. ALLOW 5 MINUTES FOR INTERNAL CAPACITANCE TO DISCHARGE BEFORE REMOVING ANY COVER.

When the circuit breaker is ON, voltage is applied to an isolated diode rectifier bridge, which contains the rectifier diodes used for line voltage rectification. The output of this bridge rectifier is connected to a capacitor filter. Capacitors are initially charged through resistive inrush limiters.

Approximately 3 seconds after the circuit breaker is turned on, a relay is energized to short the resistor limiters. This DC voltage is supplied to the high frequency inverter.

The DC rails are connected to the high frequency rail capacitors. These capacitors are high frequency, low loss type, which provides the energy storage for the high frequency inverter.

4.3 Inverter

The inverter is a series resonant, series/parallel loaded topology. A proprietary control scheme is used for regulating the power generated from the inverter. The switching devices are IGBT's. These devices provide high frequency switching to control the resonant current flow. The typical resonant operating period is approximately 10 μ Seconds. The gate control for the switching devices is provided by the application circuitry located on the CONTROL/POWER PWB. The CONTROL/POWER PWB also provides circuitry for sensing shoot thru and overcurrent conditions in the inverter.

4.4 High Voltage Transformer

The output of the High Frequency Resonant Inverter is connected to the primary of the High Voltage Transformer. The High Voltage Transformer is a set up type. Typical secondary voltages are in the range of 1kV to 4.5kV depending upon the output voltage ratings.

4.5 High Voltage Assembly

The High Voltage Assembly will vary depending upon the model ordered. The circuitry typically consists of a full wave, full bridge, or full wave doubler for voltage outputs in the range of 1kV to 8kV. The higher voltage ranges utilize various parallel, series arrangements of a full wave voltage doubler.

Output filtering is typically provided by an R-C type filter. Voltage feedback for regulation and monitoring is provided by a high bandwidth resistive/capacitive divider. Current feedback for regulation and monitoring is provided by a sense resistor connected at the low voltage end of the High Voltage Rectifier/Multiplier Circuit.

4.6 Control/Power PWB

The majority of control circuits for power supply controls are located on the CONTROL/POWER PWB. +15VDC, -15VDC, and +10VDC is generated on the CONTROL/POWER PWB. High Voltage On/Off control is accomplished by K3, and its associated circuitry. Interlock control is provided by K4.

Voltage feedback from the high voltage divider is sent to the control board via a mass terminated ribbon cable. Gain adjustment is provided on the HV PWB. The KV feedback signal is sent to the front panel DVM and to the REAR PANEL 25 pin D connector for remote monitoring. K2 provides switching between feedback and program signal for the front panel DVM's. This allows the user to preset the desired output before energizing high voltage.

Program voltages are typically ramped up to set level by a slow start circuit.

An arc sense circuit provides sensing, quench and indicator of arc conditions. Consult the operation manual for a detailed description of the arc sense control.

Current feedback from the high voltage rectifier is sent to sense resistors located on the High Voltage Assembly. Calibrated feedback is then sent to the applicable circuitry on the Control/Power Board.

U12 circuit provide visual indication of the control mode, which is in operation. These signals are sent to the FRONT PANEL ASSEMBLY for front panel status indication.

The resonant control circuitry consists of a pulse width converter. U17 generates all pulse width control signals.

Power supply inhibit circuits are provided by U22 and K3. System Fault control and Indication is provided by U19, and associated circuitry. Diagnostic signals are latched and then sent to the FRONT PANEL ASSEMBLY for status indication.

4.7 Front Panel Assembly

Front Panel controls, meters and status indications are connected to the FRONT PANEL PWB. The FRONT PANEL PWB interfaces directly to the CONTROL/POWER PWB.

4.8 Options

Due to the many variations of models and options provided in the SL Series, details of actual circuits used may differ slightly from the above descriptions. Consult Spellman's Engineering Department for questions regarding the principles of operation for the SL Series.

Chapter 5

OPTIONS

The options available for this power supply are described in this section. Interface diagrams are shown where required. Options are specified by including the option code in the model number as described in Section 1.5.

5.1 AOL - Adjustable Overload Trip

A control board jumper is moved to make the power supply shut down if it ever operates in current mode. This allows the user to set the current programming level as a trip point that will turn the power supply off with an Over Current fault if it ever tries to operate in Current Mode.

5.2 APT – Adjustable Power Trip

A third control loop is installed in the power supply, a power loop. This power loop uses an analog multiplier chip to multiply the voltage and current feedback signals to create a power feedback signal. Programming and feedback scaling is 0- 10Vdc = 0-100% of rated power. The circuit is configured to trip the power supply off with an Over Power fault if the power loop ever tries to regulate.

5.3 ARC – Arc Sense

A signal is provided on a spare pin (TB1-21) that changes state whenever the power supply detects an arc.

5.4 AT – Arc Trip

A control board jumper is moved such that the first arc sensed will shut the power supply off with an ARC fault.

5.5 CMS – Current Mode Select

A front panel switch is provided to allow the power supply to either regulate in current mode or create an over current fault when operated in current mode, which will shut down the supply. This is basically a switch selectable AOL option.

5.6 CPC – Constant Power Control

Identical to the APT Option with the exception the power supply will run and regulate when the power loop becomes active.

5.7 DPM4 - Digital Panel Meter, 4.5 Digits

The standard 3.5 digit front panel meters are replaced with 4.5 digit panel meters.

CAUTION

5.8 EFR - External Fault Relay

The external fault relay option provides a set of customer accessible relay contacts that are controlled by the fault status circuitry of the applicable SL Series power supply. A standard SL power supply will revert to the “Power Down” mode with a visual front panel indication if any of the following fault conditions occur:

- **Overvoltage:** Greater than 110% of maximum output voltage was produced by the power supply.
- **Overcurrent:** Greater than 104% of maximum output current was produced by the power supply or the AOL circuitry was activated.
- **Overtemperature:** Excessive temperature has been sensed within the chassis.
- **Regulation Error:** Lack of required output power to maintain regulation
- **Arc (Shutdown):** Arc sensing circuit has shut down the supply due to excessive arcing. With the installation of the EFR option, if any of these faults occur, a relay will be activated to provide a remote indication that the power supply has reverted to the “power down” mode. The common and normally open or normally closed set of contacts are provided (jumper selectable). Relay contacts are rated at 1A at 30Vdc or 0.5A at 48Vac. Connections on the rear panel 25 pin D connector (J5) can be made as follows:

J5-12 Relay Common.

J5-13 Normally Open/Normally Closed (jumper selectable).

Resetting the front panel and EFR relay is accomplished by depressing the green front panel HV OFF push-button switch, which reverts the power supply back to the “Standby” mode. Removal and reapplication of the AC line input voltage will also reset any fault. The circuitry and components required for the EFR option are installed at the factory when this option is ordered.

5.9 FCV – Fine Control Voltage

This option adds a second potentiometer to the front panel of the unit. This allows for a finer local adjustment of the output voltage setting.

5.10 IO – Instant On

When the Instant On Option is ordered, the High Voltage is enabled as soon as line voltage is applied when the circuit breaker is in the ON position. (See Figure 5.3) To enable Instant On, keep the jumper between J5-14 and J5-15 attached. Connect an additional jumper from J5-15 to J5-16 as shown in Figure 5.3.

The Power Supply will generate programmed High Voltage whenever the circuit breaker is in the ON position, and line voltage is applied.

5.11 LL(X) – Lead Length

Extra-long high voltage output cable of standard lengths of 20, 40, 60 and 100 feet can be provided. Non standard lengths can be custom ordered.

5.12 NAD – No Arc Detect

This option removes the arc intervention circuitry from the power supply. Care must be exercised when using this option as damage to the HV multiplier could occur.

5.13 NSS – No Slow Start

The standard 6 second long linear ramp of output voltage is removed allowing the high voltage to “step” to its set point when enabled.

5.14 PN – Positive/Negative

Reversible polarity option. Units that are not inherently reversible by design (10kV to 50kV) can have their output polarity reversed by the process of exchanging the high voltage multiplier section.

Models from 0.5 kV to 8kV:

For units from 0.5 kV to 8kV, the polarity may be reversed in the field via an internal wiring change by following the procedures shown in Figure 5.1.

Models from 10kV to 130kV:

When this option is ordered, a second multiplier is provided to permit the user to replace the existing multiplier with another of reverse polarity. See Figure 5.2 for a step by step procedure.

5.15 RFR – Remote Fault Reset

This option provides the ability to reset any power supply faults that might occur via toggling a signal on the rear panel interface.

5.16 ROV – Remote Over Voltage

The programming signal for the over voltage comparator circuit is made available to the customer remotely, allowing the power supply to be set to trip the OVP circuit anywhere from 0 -110% of rated output voltage.

5.17 SL – Slides

Industry standard rack mounted slides are installed on the power supply.

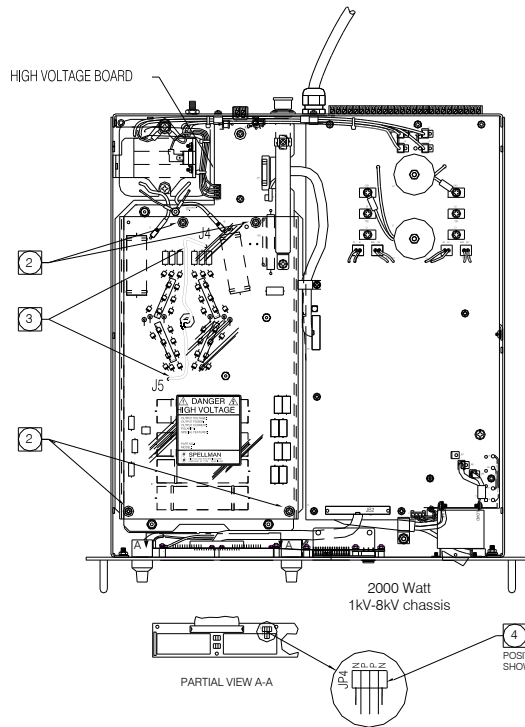
5.18 SS(X) – Slow Start(X)

The standard slow start is modified to provide a time of (X) seconds. Time frames of 0.1 seconds to 120 seconds can be accommodated.

5.19 Custom Designed Models – X Numbers

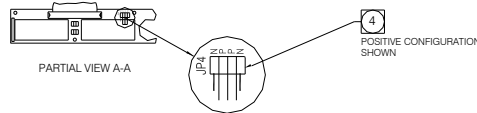
Units built to customer specification are assigned an X number by the factory. If this unit is an X model, a specification control sheet is added at the end of the test of this instruction manual.

Spellman welcomes the opportunity to customize units to fit your requirements or to develop new products for your applications. Contact the Spellman Sales Department with your needs.

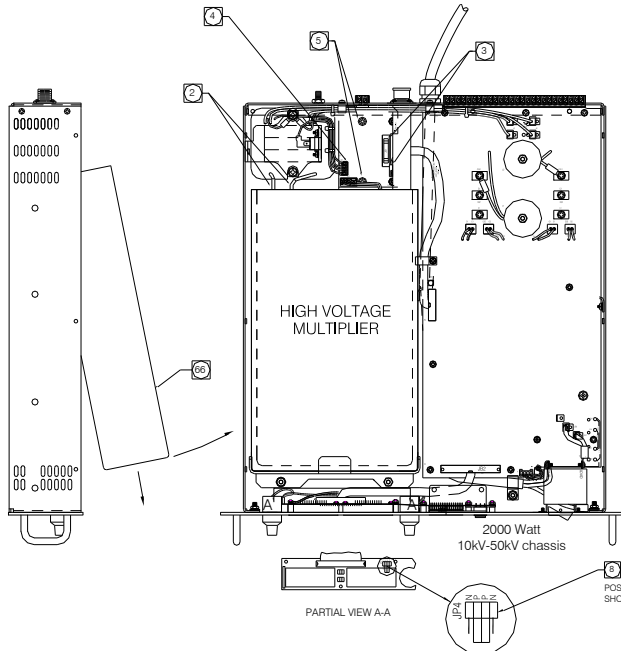


TURN UNIT OFF. UNPLUG LINE CORD FROM AC OUTLET AND WAIT FOR 5 MINUTES BEFORE PROCEEDING TO CHANGE THE HIGH VOLTAGE MULTIPLIER.

- 1 REMOVE COVER BY UNSCREWING AND REMOVING 12 SCREWS THAT MOUNT COVER TO CHASSIS AND FRONT PANEL.
- 2 REMOVE 4 SETS OF HARDWARE THAT HOLD THE LEXAN COVER TO THE HIGH VOLTAGE BOARD, AND REMOVE COVER.
- 3 SWAP BLACK AND WHITE WIRES BETWEEN J4 AND J5 AS FOLLOWS:
FOR POSITIVE POLARITY:
BLACK WIRE ON J4 AND WHITE WIRE ON J5.
FOR NEGATIVE POLARITY:
WHITE WIRE ON J4 AND BLACK WIRE ON J5.
- 4 CHANGE POSITION OF JP4 JUMPERS ON FRONT PANEL BOARD TO MATCH POLARITY OF UNIT. I.e 2 JUMPERS MUST BE ON "N" POSITIONS FOR NEGATIVE UNITS AND ON "P" POSITIONS FOR POSITIVE UNITS.
- 5 REINSTALL LEXAN COVER AND RELATED HARDWARE. REINSTALL POWER SUPPLY'S COVER AND ALL HARDWARE BEFORE TURNING UNIT ON.

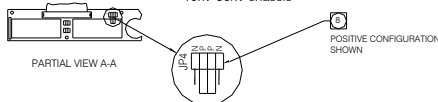


**Figure 5.1 – Polarity Reversal Procedures
2000W, 1kV to 8kV Chassis**



TURN UNIT OFF. UNPLUG LINE CORD FROM AC OUTLET AND WAIT FOR 5 MINUTES BEFORE PROCEEDING TO CHANGE THE HIGH VOLTAGE MULTIPLIER.

- 1 REMOVE COVER BY UNSCREWING AND REMOVING 12 SCREWS THAT MOUNT COVER TO CHASSIS AND FRONT PANEL.
- 2 UNPLUG HIGH VOLTAGE LEADS FROM ASSEMBLY.
- 3 UNPLUG CABLE FROM JB1 AND REMOVE CABLE SHIELD FROM FASTON TAB ON BOARD.
- 4 UNPLUG CONNECTOR FROM JB2.
- 5 REMOVE 2 SCREWS THAT HOLD THE POLYETHYLENE ENCLOSURE AND THE BOARD TO THE CHASSIS
- 6 CAREFULLY TILT UP AND SLIDE OUT MULTIPLIER.
- 7 INSTALL NEW MULTIPLIER BY FOLLOWING STEPS 6 THRU 2 IN REVERSE.
- 8 CHANGE POSITION OF JP4 JUMPERS ON FRONT PANEL BOARD TO MATCH POLARITY OF UNIT. I.e 2 JUMPERS MUST BE ON "N" POSITIONS FOR NEGATIVE UNITS AND ON "P" POSITIONS FOR POSITIVE UNITS.
- 9 INSTALL COVER AND ALL HARDWARE BACK BEFORE TURNING UNIT ON.



**Figure 5.2 – Polarity Reversal Procedures
2000W, 10kV to 50kV Chassis**

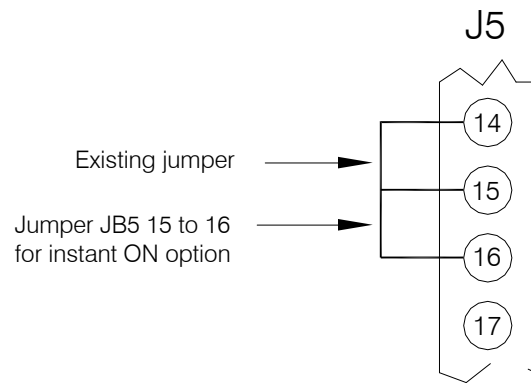


Figure 5.3 – Instant ON

Chapter 6

MAINTENANCE

This section describes periodic servicing and performance testing procedures.

WARNING

THIS POWER SUPPLY GENERATES VOLTAGES THAT ARE DANGEROUS AND MAY BE FATAL . OBSERVE EXTREME CAUTION WHEN WORKING WITH HIGH VOLTAGE.

6.1 Periodic Servicing

Approximately once a year (more often in high dust environments), disconnect the power to the unit and remove the top cover. Use compressed air to blow dust out of the inside of the unit. Avoid touching or handling the high voltage assembly. Be sure that the fans are not obstructed and spins freely. The fan has sealed bearings and does not need lubrication. Be sure to replace the top cover before operating for proper cooling.

6.2 Performance Test

WARNING

HIGH VOLTAGE IS DANGEROUS.

ONLY QUALIFIED PERSONNEL SHOULD PERFORM THESE TESTS.

High voltage test procedures are described in Bulletin STP-783, Standard Test Procedures for High Voltage Power Supplies. Copies can be obtained from the Spellman Customer Service Department. Test equipment, including an oscilloscope, a high impedance voltmeter, and a high voltage divider such as the Spellman HVD-100 or HVD-200, is needed for performance tests. All test components must be rated for operating voltage.

6.3 High Voltage Dividers

High voltage dividers for precise measurements of output voltage with an accuracy up to 0.1% are available. An HVD-100 is used for voltages up to 100KV. An HVD-200 measures up to 200KV. The Spellman divider is designed for use with differential voltmeters or high impedance digital voltmeters. The high input impedance is ideal for measuring high voltage low current sources, which would be overloaded by traditional lower impedance dividers.

Chapter 7

REPLACEMENT PARTS

7.1 Replacement Parts

Contact the Spellman Customer Service Department for parts lists for specific models.

Parts and subassemblies for Spellman's high voltage power supplies are available. It is recommended that only qualified personnel perform the repairs. High voltage is dangerous; even minor mistakes in repairs can have serious consequences.

When requesting parts please give the model number and serial number of the power supply.

7.2 Correspondence and Ordering Spare Parts

Each power supply has an identification label on the rear of the chassis that bears its model and serial number.

When requesting engineering or applications information, please state the model and serial number of the power supply.

When ordering spare parts, please specify the part number, the component function and the model and serial number of the unit.

Chapter 8

FACTORY SERVICE

8.1 Warranty Repairs

During the Warranty period, Spellman will repair all units free of charge. The Warranty is void if the unit is worked on by other than Spellman personnel. See the Warranty in the rear of this manual for more information. Follow the return procedures described in Section 8.2. The customer shall pay for shipping to and from Spellman.

8.2 Factory Service Procedures

Spellman has a well-equipped factory repair department. If a unit is returned to the factory for calibration or repair, a detailed description of the specific problem should be attached.

For all units returned for repair, please obtain an authorization to ship from the Customer Service Department, either by phone or mail prior to shipping. When you call, please state the model and serial numbers, which are on the plate on the rear of the power supply, and the purchase order number for the repair. A Return Material Authorization Code Number (RMA Number) is needed for all returns. This RMA Number should be marked clearly on the outside of the shipping container. Packages received without an RMA Number will be returned to the customer. The Customer shall pay for shipping to and from Spellman.

A preliminary estimate for repairs will be given by phone by Customer Service. A purchase order for this amount is requested upon issuance of the RMA Number. A more detailed estimate will be made when the power supply is received at the Spellman Repair Center. In the event that repair work is extensive, Spellman will call to seek additional authorization from your company before completing the repairs.

8.3 Ordering Options and Modifications

Many of the options listed in Chapter 5 can be retrofitted into Spellman's power supplies by our factory. For prices and arrangements, contact the Spellman Sales Department.

8.4 Shipping Instructions

All power supplies returned to Spellman must be sent shipping prepaid. Pack the units carefully and securely in a suitable container, preferably in the original container, if available. The power supply should be surrounded by at least four inches of shock absorbing material. Please return all associated materials, i.e. high voltage output cables, interconnection cables, etc., so that we can examine and test the entire system.

All correspondence and phone calls should be directed to:

Spellman High Voltage Electronics Corp.
475 Wireless Boulevard
Hauppauge, New York 11788
TEL: (631) 630-3000 FAX: (631) 435-1620
E-Mail: sales@Spellmanhv.com

To obtain information on Spellman's product warranty please visit our website at:

<http://www.spellmanhv.com/en/About/Warranty.aspx>

