

Instruction Manual

PCM SERIES

High Voltage Power Supply

MODEL :
SERIAL# :
DATE :

SPELLMAN
HIGH VOLTAGE ELECTRONICS
CORPORATION
475 Wireless Blvd.
Hauppauge, New York, 11788

+1(631) 630-3000*FAX: +1(631) 435-1620*
E-mail: sales@spellmanhv.com
Website: www.spellmanhv.com

IMPORTANT SAFETY PRECAUTIONS

SAFETY

THIS POWER SUPPLY GENERATES VOLTAGES THAT ARE DANGEROUS AND MAY BE FATAL.
OBSERVE EXTREME CAUTION WHEN WORKING WITH THIS EQUIPMENT.

High voltage power supplies must always be grounded.

Do not touch connections unless the equipment is off and the Capacitance of both the load and power supply is discharged.

Allow five minutes for discharge of internal capacitance of the power supply.

Do not ground yourself or work under wet or damp conditions.

SERVICING SAFETY

Maintenance may require removing the instrument cover with the power on.

Servicing should be done by qualified personnel aware of the electrical hazards.

WARNING note in the text call attention to hazards in operation of these units that could lead to possible injury or death.

CAUTION notes in the text indicate procedures to be followed to avoid possible damage to equipment.

Copyright © 2000, Spellman High Voltage Electronics Corporation. All Rights Reserved.
This information contained in this publication is derived in part from proprietary and patent data. This information has been prepared for the express purpose of assisting operating and maintenance personnel in the efficient use of the model described herein, and publication of this information does not convey any right to reproduce it or to use it for any purpose other than in connection with installation, operation, and maintenance of the equipment described.

WICHTIGE SICHERHEITSHINWEISE

SICHERHEIT

DIESES HOCHSPANNUNGSNETZTEIL ERZEUGT LEBENSGEFÄHRLICHE HOCHSPANNUNG.
SEIN SIE SEHR VORSICHTIG BEI DER ARBEIT MIT DIESEM GERÄT.

Das Hochspannungsnetzteil muß immer geerdet sein.

Berühren Sie die Stecker des Netzteiles nur, wenn das Gerät ausgeschaltet ist und die elektrischen Kapazitäten des Netzteiles und der angeschlossenen Last entladen sind.

Die internen Kapazitäten des Hochspannungsnetzteiles benötigen ca. 5 Minuten, um sich zu entladen.

Erden Sie sich nicht, und arbeiten Sie nicht in feuchter oder nasser Umgebung.

SERVICESICHERHEIT

Notwendige Reparaturen können es erforderlich machen, den Gehäusedeckel während des Betriebes zu entfernen.

Reparaturen dürfen nur von qualifiziertem, eingewiesenem Personal ausgeführt werden.

“WARNING” im folgenden Text weist auf gefährliche Operationen hin, die zu Verletzungen oder zum Tod führen können.

“CAUTION” im folgenden Text weist auf Prozeduren hin, die genauestens befolgt werden müssen, um eventuelle Beschädigungen des Gerätes zu vermeiden.

PRECAUTIONS IMPORTANTES POUR VOTRE SECURITE

CONSIGNES DE SÉCURITÉ

CETTE ALIMENTATION GÉNÈRE DES TENSIONS QUI SONT DANGEUREUSES ET PEUVENT ÊTRE FATALES.
SOYEZ EXTRÊMEMENT VIGILANTS LORSQUE VOUS UTILISEZ CET ÉQUIPEMENT.

Les alimentations haute tension doivent toujours être mises à la masse.

Ne touchez pas les connectiques sans que l'équipement soit éteint et que la capacité à la fois de la charge et de l'alimentation soient déchargées.

Prévoyez 5 minutes pour la décharge de la capacité interne de l'alimentation.

Ne vous mettez pas à la masse, ou ne travaillez pas sous conditions mouillées ou humides.

CONSIGNES DE SÉCURITÉ EN CAS DE REPARATION

La maintenance peut nécessiter l'enlèvement du couvercle lorsque l'alimentation est encore allumée.

Les réparations doivent être effectuées par une personne qualifiée et connaissant les risques électriques.

Dans le manuel, les notes marquées « **WARNING** » attire l'attention sur les risques lors de la manipulation de ces équipements, qui peuvent entraîner de possibles blessures voire la mort.

Dans le manuel, les notes marquées « **CAUTION** » indiquent les procédures qui doivent être suivies afin d'éviter d'éventuels dommages sur l'équipement.

IMPORTANTI PRECAUZIONI DI SICUREZZA

SICUREZZA

QUESTO ALIMENTATORE GENERA TENSIONI CHE SONO PERICOLOSE E POTREBBERO ESSERE MORTALI.
PONI ESTREMA CAUTELA QUANDO OPERI CON QUESTO APPARECCHIO.

- Gli alimentatori ad alta tensione devono sempre essere collegati ad un impianto di terra.
- Non toccare le connessioni a meno che l'apparecchio sia stato spento e la capacità interna del carico e dell'alimentatore stesso siano scariche.
- Attendere cinque minuti per permettere la scarica della capacità interna dell'alimentatore ad alta tensione.
- Non mettere a terra il proprio corpo oppure operare in ambienti bagnati o saturi d'umidità.

SICUREZZA NELLA MANUTENZIONE.

- Manutenzione potrebbe essere richiesta, rimuovendo la copertura con apparecchio acceso.
- La manutenzione deve essere svolta da personale qualificato, coscio dei rischi elettrici.
- Attenzione alle **AVVERTENZE** contenute nel manuale, che richiamano all'attenzione ai rischi quando si opera con tali unità e che potrebbero causare possibili ferite o morte.
- Le note di **CAUTELA** contenute nel manuale, indicano le procedure da seguire per evitare possibili danni all'apparecchio.

Table of Contents

	PAGE
1. INTRODUCTION	
1.1 Description Of The PCM Series	1
1.2 PCM Specifications	1
1.3 Standard Features.....	2
1.4 Options.....	2
1.5 Interpreting The Model Number.....	2
2. INSPECTION & INSTALLATION	
2.1 Initial Inspection	3
2.2 Mechanical Installation.....	3
3. OPERATING INSTRUCTIONS	
3.1 Operation	5
3.2 Standard Features.....	6
4. PRINCIPLES OF OPERATION	
4.1 AC to DC Rectifier and Associated Circuits	10
4.2 High Frequency Inverter	10
4.3 High Voltage Circuits	10
4.4 Control Circuits.....	10
4.5 Options.....	11
5. OPTIONS	
5.1 Floating Ground.....	12
5.2 No Slow Start.....	12
5.3 Non-Standard Slow Start	12
5.4 Extra Length Output Cable	12
5.5 Focus.....	12
5.6 Grid	12
5.7 Custom Designed Models.....	12
5.8 Filament	12
6. MAINTENANCE	
6.1 Periodic Servicing.....	14
6.2 Performance Test	14
6.3 High Voltage Dividers	14

7. FACTORY SERVICE

7.1 Warranty Repairs17
7.2 Factory Service Procedures17
7.3 Ordering Options and Modifications17
7.4 Shipping Instructions17

APPENDIX

A. Specification Controls (Custom Models Only)

Chapter 1

INTRODUCTION

1.1 Description of the PCM Series

The PCM series of high voltage power supplies provides very well regulated, low ripple high voltage in a highly efficient, compact design. The dramatically reduced size of the PCM Module, compared to traditional high voltage modules, is obtained by a state of the art off-line resonant converter. The resonant converter utilizes a unique control scheme, which allows constant frequency operation while maintaining high efficiency. The high efficiency is obtained by zero current switching (ZCS) resonant control. High operating frequency, typically 50KHz, allows for very low ripple and excellent dynamic response capabilities.

The DC output voltage and current are controllable over the full range of operation. Monitoring and control signals are provided for simple, yet flexible control of the power supply. The PCM series operates from 85 - 265VAC, at 50/60 Hz single phase. The input power factor corrected, no reconfiguring is required. The PCM series operates at 120W continuous without the need for forced air cooling. The ambient temperature must be kept below the maximum rating as specified in 1.2. Consult Spellman Sales Department for higher power capabilities of the PTV series (up to 400W peak).

The standard warranty applies to the PCM modules. Consult factory about the warranty for custom PCM modules.

1.2 PCM Specifications

- **Output Control:** Voltage and current are externally programmable over the entire range from zero to maximum rating via 0-10VDC reference or potentiometer. (Other scale factors for control and monitoring can be provided i.e. 1 volt per 10KV, 1 volt per 10mA etc.).
- **Input Voltage:**
85-265VAC, 47-63Hz, power factor corrected
UL® rated for 85-250VAC input for 1kV to 5kV models.
- **Power Factor:**
FL: 0.99, NL: 0.98

- **Regulation:**
Load Regulation: 0.01% of full voltage for a no load to full load change.
Line Regulation: +/-0.005% of full voltage over the specified input voltage range.
- **Current Regulation:**
Load Regulation: 0.01% from 0 voltage to full voltage.
Line Regulation: ±0.01% of full current over the specified input voltage range.
- **Ripple:** 0.1% p-p of output voltage.
- **Polarity:** Positive or Negative polarity with respect to ground. (Specify at time of ordering).
- **Stability:** 0.02% per 8 hours after 1/2 hour warm up.
- **Temperature Coefficient:** 100 ppm per °C.
- **Temperature:**
Operating: 0°C to -45°C
Storage: -20°C to +85°
- **Monitoring:**
0-10 VDC corresponding to 0-100% of output voltage
1-10VDC corresponding to 0-100% of output current.(Other scale factors available).

IMPORTANT

This control signal is not a safety interlock and should not be used for protection from high voltage generation for safety purposes.

- **Control:**
Logic level control for high voltage enable/disable.
- **Interlock:**
Open interlock will shut down unit..

1.3 Standard Features

The PCM series incorporates several standard features designed to optimize user operation.

Slow Start: Provides a gradual increase in high voltage output until the maximum set point is reached. Various slow start times can be accommodated. Consult Spellman's Sales Department for information on slow start options.

Overvoltage Protection: An overvoltage protection circuit monitors the output for excessive voltage generation. Overvoltage conditions can be caused by excessive input program signal. If an overvoltage condition is detected, the power supply is latched off until input power is reset.

PS Fault Indication: A PS Fault Indicator and a PS Fault Output on J1, indicate an OVP or a regulation error.

Power Factor and Universal Input: The input voltage of the PCM can operate within the range from 85VAC to 265VAC. The power factor is actively corrected across this entire range and is better than 0.99 at full load.

Internal EMI Filter and Fuse Protection: An internal EMI filter and fuse provide protection against line voltage surges and power supply faults.

1.3.1 Remote Operating Features

Remote Programming: Allows remote adjustment of the output voltage and current via an external voltage source.

Remote Monitor: Allows remote monitoring of the Output voltage and current.

High Voltage Enable/Disable: Allows remote ON/OFF control of the high voltage.

+10VDC Reference: A +10VDC reference is provided for remote programming via a potentiometer or resistive divider.

1.4 Options

The options available are listed in Table 1.1. See section 5 for more information on the options along with operating and set-up instructions. With few exceptions, these options can be retrofitted to your power supply at

the factory in a short time. For price and retrofit arrangements, contact the Spellman Sales Department.

CODE DISCRIPTION	
•	NSS No Slow Start
•	SS(X) Non-Standard Slow Start
•	LL(X) Extra Length Output Cable
•	FG
•	Output Connector
•	Focus Outputs
•	Grid Outputs
•	Filament Output

1.5 Interpreting the Model Number:

The model number of the power supply describes its capabilities. After the series name is:

- (1) The maximum voltage in kilovolts.
- (2) The polarity of the output – positive (P), or negative (N).
- (3) The maximum output in watts.
- (4) The option code for all options that are included.
- (5) Custom "X" number representing details listed in a separate specification control drawing.

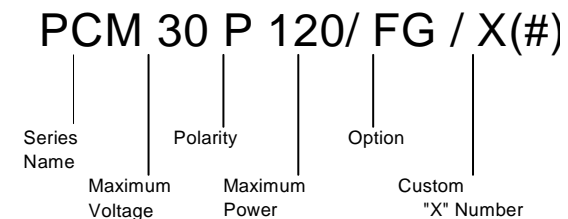

Chapter 2

Inspection and Installation

Initial inspection and preliminary checkout procedures are recommended. For safe operation, please follow the step-by-step procedures described in Chapter 3, Operating Instructions.

2.1 Initial Inspection

Inspect the package exterior for evidence of damage due to handling in transit. Notify the carrier and Spellman immediately if damage is evident. Do not destroy or remove any of the packing material used in a damaged shipment. After unpacking, inspect the panel and chassis for visible damage.

Fill out and mail the Warranty Registration card accompanying the unit. Standard PCM120 high voltage power supplies and components are covered by warranty. Custom and special order models (with an X suffix in the model number) are also covered by warranty.

2.2 Mechanical Installation

The PCM series module power supplies are designed for installation into existing or newly developed OEM equipment. The power supply can also easily fit into bench top applications or test set requirements. Standard unit dimensions are shown in Figure 2.1

For custom mounting requirements or specific package size requirements consult Spellman's Sales Department. Spellman has many package designs available, or can design a specific enclosure for your requirements.

The PCM series utilizes solid encapsulations for corona free operation. No periodic maintenance is required. Lower voltage units (under 6KV) utilizes air insulation. Due to conservative voltage spacing design, periodic maintenance is not required.

SIGNAL CONNECTOR J1	
PIN	FUNCTION
1	Remote mA Program
2	Remote kV Program
3	Enable (L)/Disable (H)
4	mA Monitor
5	Interlock Return
6	Interlock
7	kV Monitor
8	Local kV Program
9	Power Supply Fault
10	+10V Reference
11	Signal Return
12	Spare
13	Spare
14	Spare
15	Local mA Program

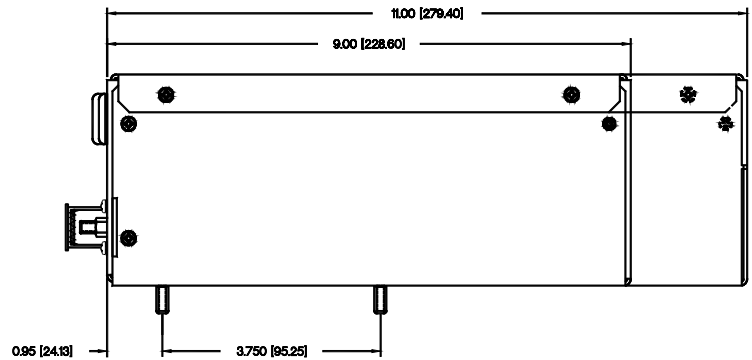
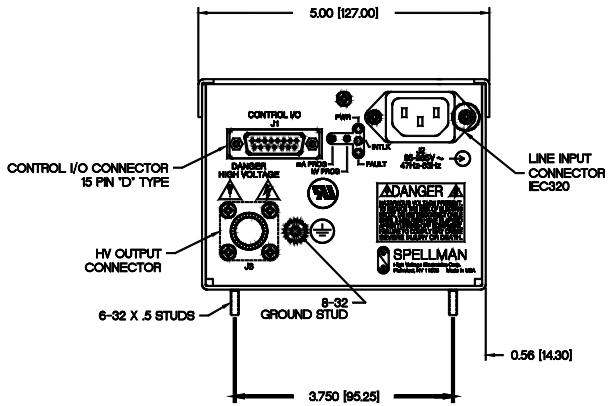
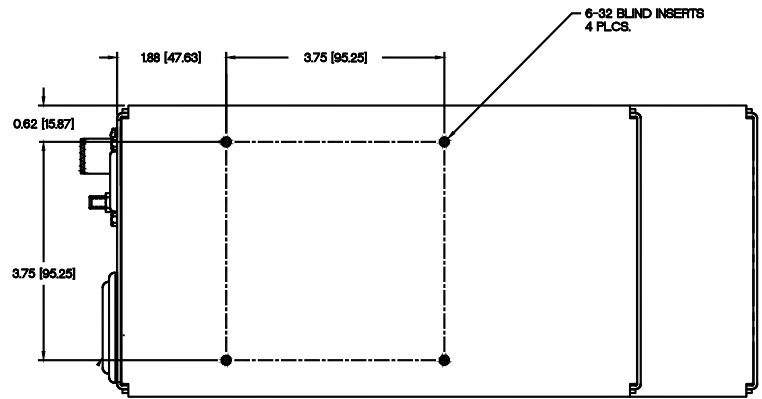

Figure 2.1 Unit Dimensions

Chapter 3

Operating Instructions

3.1 Operation

WARNING

THIS EQUIPMENT GENERATES DANGEROUS VOLTAGES THAT MAY BE FATAL. PROPER GROUNDING OF ALL HIGH VOLTAGE EQUIPMENT IS ESSENTIAL.

IMPORTANT:

Before connecting the power supply to the AC line, follow this step-by-step procedure.

Do not connect the power supply to the AC line until Step G is reached.

Failure to follow these procedures may void the warranty.

- A) Insure that the high voltage cable is properly terminated to the load. Insure that all circuits connected to the high voltage output are safely interlocked against accidental contact. Insure external load is discharged.
- B) Check the input voltage rating on the serial nameplate of the supply and make certain that this is the rating of the available power source
- C) **PROPER GROUNDING TECHNIQUE:** The chassis of high voltage power supplies must be grounded, preferably to a water system ground using copper pipe or other earth ground. See Figure 3.1 for a typical operating setup. The return line from the load should be connected to the power supply chassis. Using a separate external ground at the load is not recommended. An IEC 320 connector is provided for connection to the line voltage source. A standard three prong line cord is also provided.
- D) **Options Note :** See section 5 for hook up and operating instructions for the options on your unit. Custom models may also require set up changes.
- E) **Hook-up:** Connect control and monitoring connections as described in this manual.
- F) For initial turn-on, program the voltage and current for zero output. Connect the enable/disable signal to disable, open the interlock.
- G) The input power cable may now be connected to the AC power line.
- H) Enable the power supply via the enable/disable logic signal, close the interlock.
- I) Slowly program the output voltage and current to desired level. Monitor the output voltage and current via the monitoring test points. Note equipment operation is normal, i.e. Load is behaving as predicted.
- J) To turn high voltage off, use the enable/disable signal. If equipment is to be kept off for extended periods, disconnect power supply from line voltage source.

Note: If an over voltage condition occurs, the power supply will latch off. To reset the power supply, remove the line voltage and reconnect, or toggle the enable/disable signal.

WARNING

**AFTER TURNOFF, DO NOT HANDLE THE LOAD UNTIL THE CAPACITANCE HAS BEEN DISCHARGED!
LOAD CAPACITANCE MAY BE DISCHARGED BY SHORTING TO GROUND.**

WARNING

THE VOLTAGE MONITOR ON THE POWER SUPPLY FRONT PANEL DOES NOT READ THE OUTPUT VOLTAGE WHEN THE POWER IS TURNED OFF, EVEN IF A CHARGE STILL EXISTS ON THE LOAD.

CAUTION

ALWAYS OPERATE THE UNIT WITH THE COVER ON. DO NOT ATTEMPT TO ACCESS OR REPAIR ANY INTERNAL CIRCUITS. DANGEROUS AND LETHAL VOLTAGES ARE GENERATED INSIDE THE MODULE.

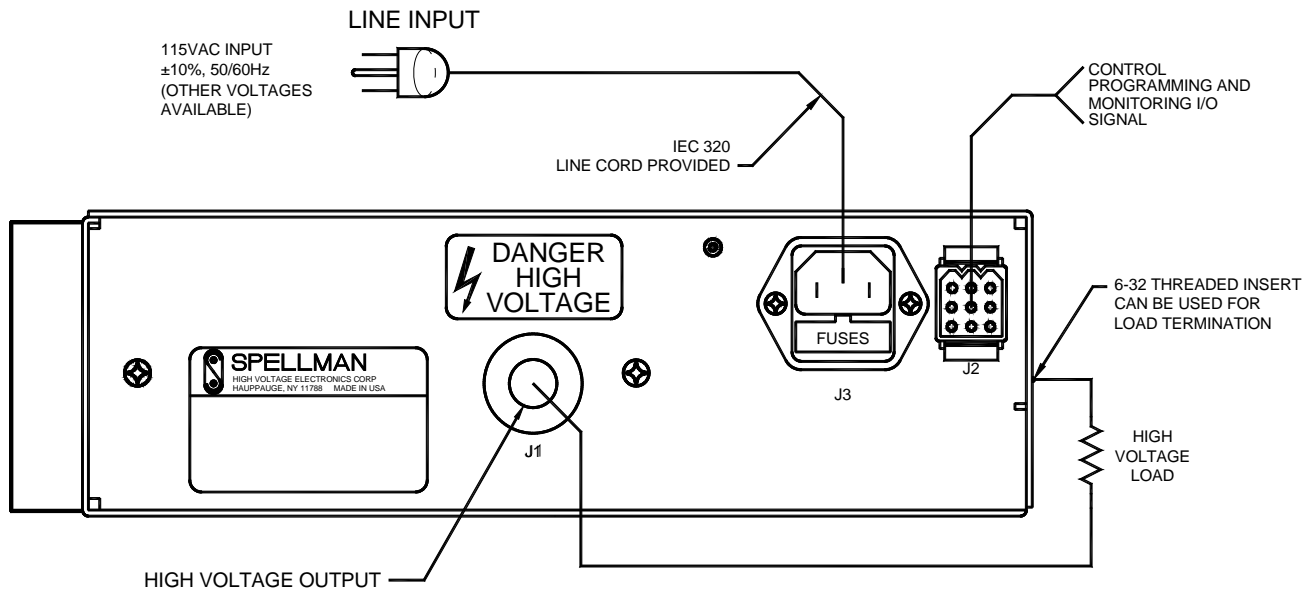

Figure 3.1 Typical Operating Set Up

3.2 Standard Features

A note on remote interface circuitry and remote signal grounding: whenever possible, electrical isolation should be provided when interfacing with any high voltage power supply. For enable/disable signal connections, an isolated relay or optocoupler should be used. For PS Fault indication an optocoupler should be used. If possible, analog programming and monitoring signals should be isolated via analog isolation amplifiers. Spellman application engineers are available to assist in interface circuitry design. All interface cables should be properly shielded. All power supply signals should be referenced to the power supplies signal ground or power supply chassis ground

Local Programming: The mA and KV controls on the front panel can be used to control the output of the PCM. For local KV control, jump J1-2 to J1-8. For local mA control, jump J1-1 to J1-15. See Figure 3.2.

REMOTE PROGRAMMING: Allows remote adjustment of the output voltage and current via an external voltage source. 0-10VDC signal is supplied to Pin 2 of the control input connector for voltage programming and 0-10 VDC signal is supplied to Pin 1 of the control input connector for current programming. Programming signals should be referenced to Pin 11 of the control input connector signal ground. By adjusting the voltage source from 0 volts (zero output) to 10 volts (full rated output) the desired output can be selected. See Figure 3-3A for wiring diagram and specifications.

An alternate method of controlling the output remotely is by using external resistance such as a potentiometer or a resistor network. See Figure 3.3B for wiring diagram.

Remote Monitoring: Test points are made available for monitoring the voltage and current output. The test points are always positive regardless of the output polarity, where zero (0) to 10 (10) volts equals 0-100% of output. See Figure 3.4 for test point wiring.

Enable/Disable Control: Remote control of the high voltage on and high voltage off can be done via the enable/disable logic control. See Figure 3.5 for recommended interface circuits.

WARNING

It is extremely dangerous to use this circuit to inhibit high voltage generation for the purpose of servicing or approaching any area of load considered unsafe during normal use.

Interlock: A safety interlock is provided on pins J1-5 and J1-6. When the interlock is open, the PCM is incapable of producing high voltage. See Figure 3.6.

PS Fault: A logic signal is provided which can be used to determine if the OVP or Reg. Error Shutdown is active. See Figure 3.7

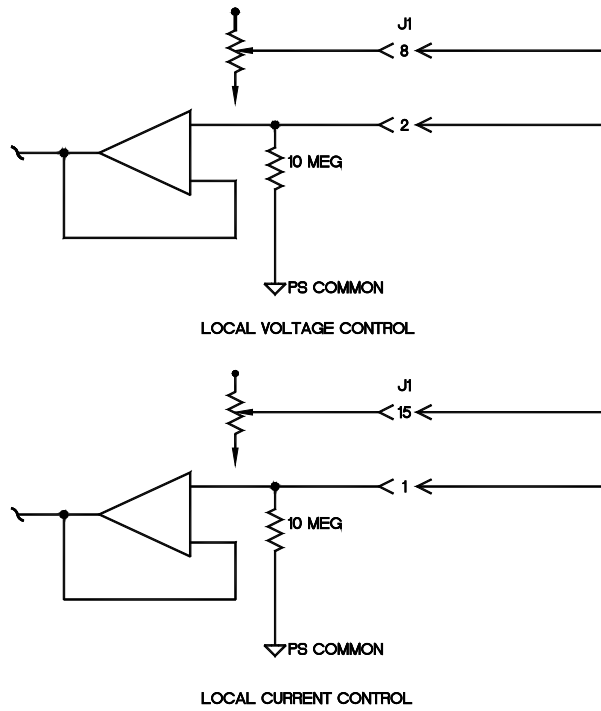

Figure 3.2 Local Programming Via Voltage Source

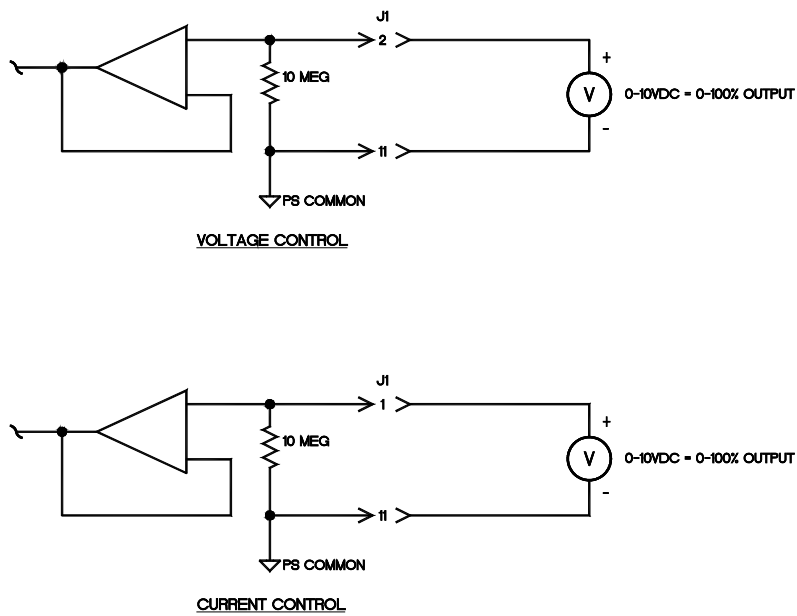

Figure 3.3A Remote Programming Via Voltage Source

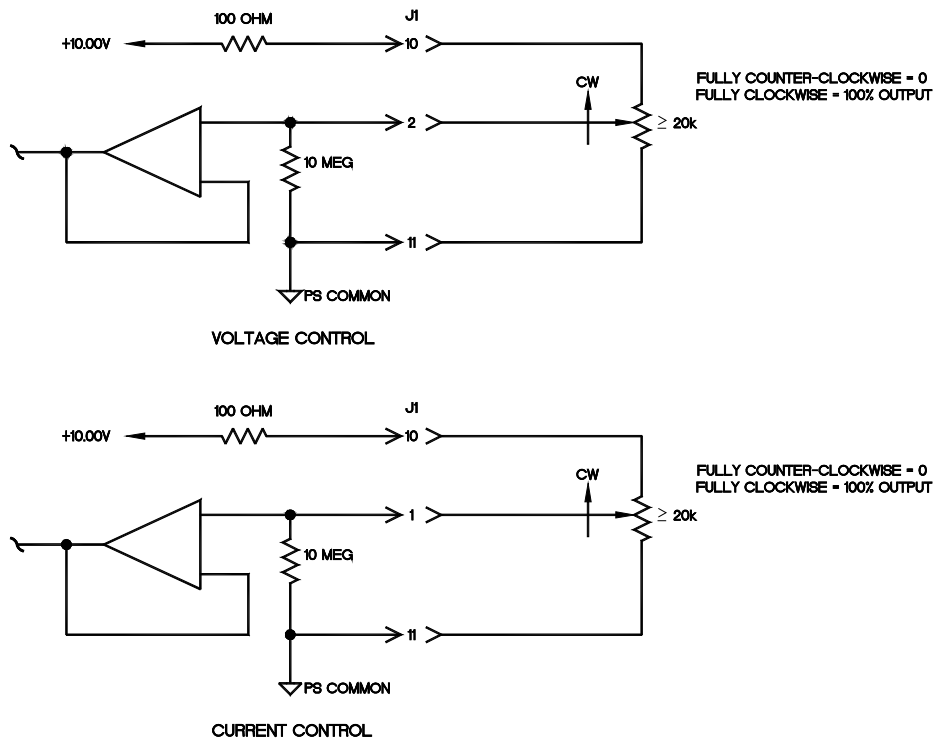

Figure 3.3B Remote Programming Via External Resistance

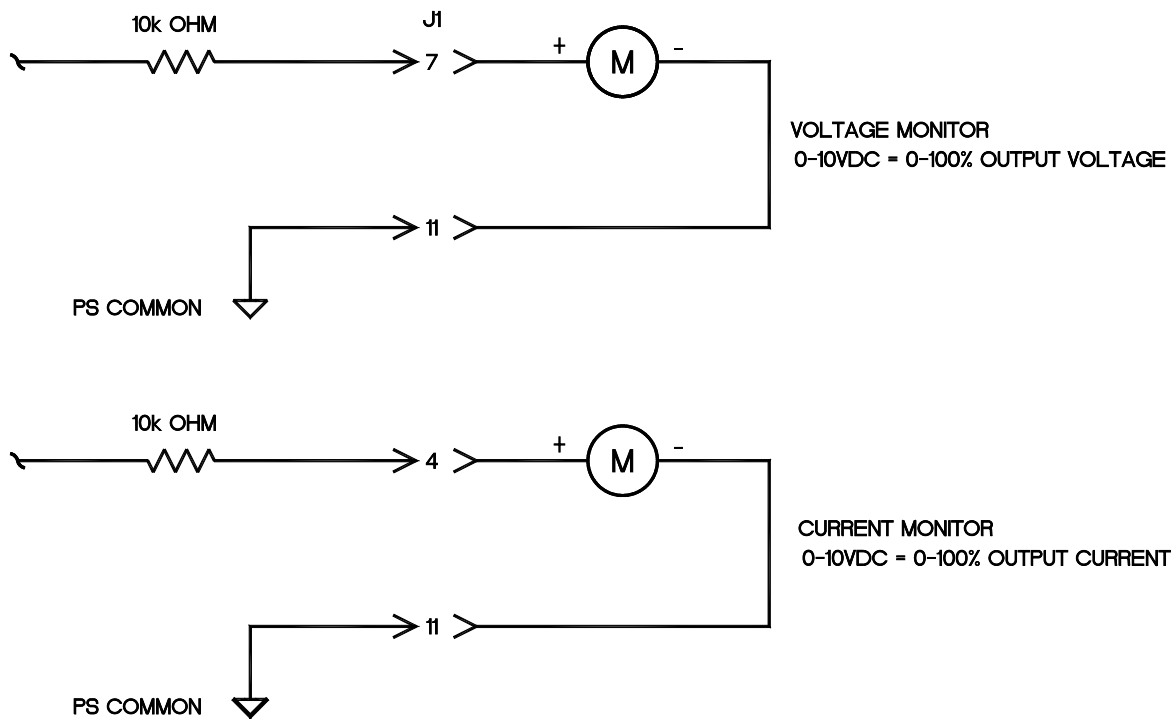

Figure 3.4 Remote Monitoring

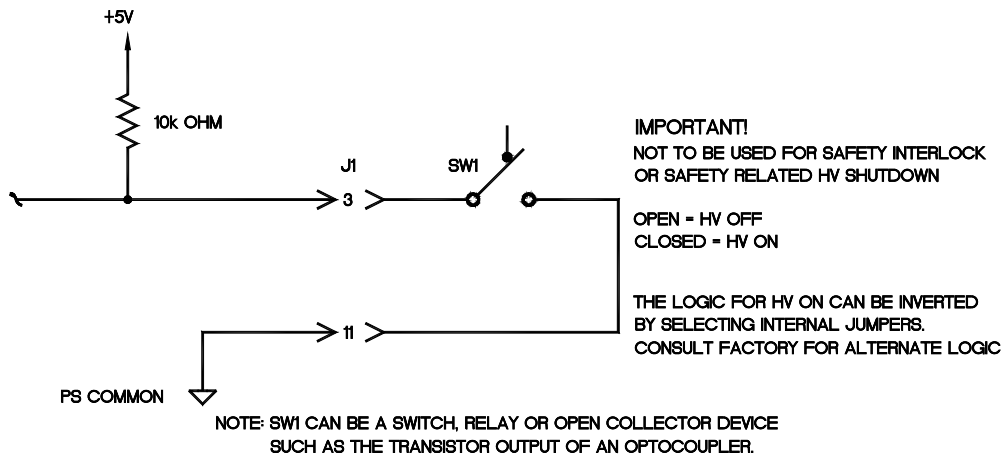

Figure 3.5 Enable/Disable Control

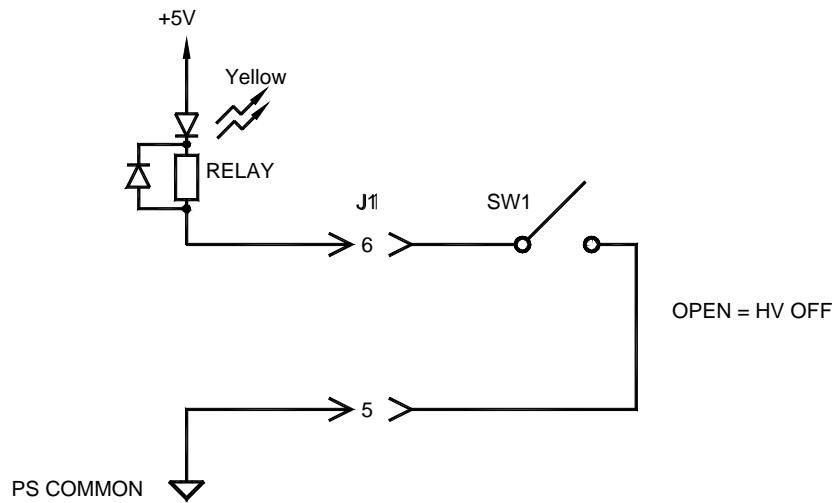

Figure 3.6 Safety Interlock

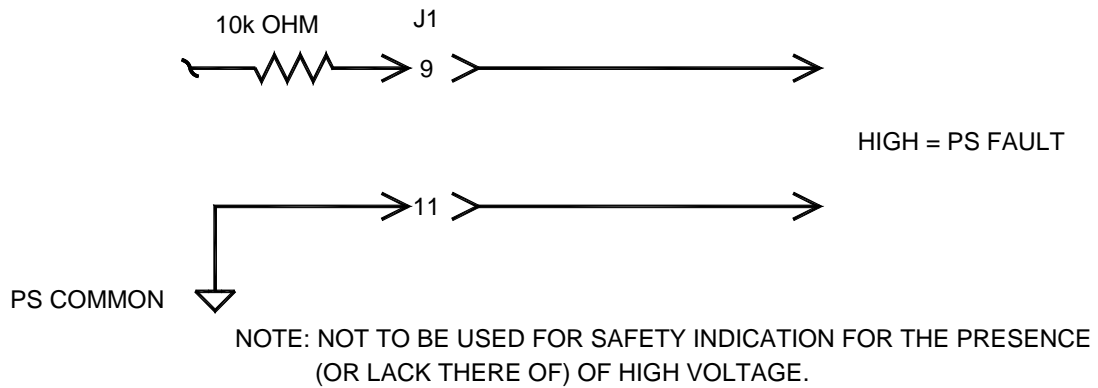

Figure 3.7 Power Supply Fault Indicator

Chapter 4

PRINCIPLES OF OPERATION

The PCM Series of high voltage power supplies utilizes sophisticated power conversion technology.

Advanced analog and power conversion techniques are used in the PCM series. The intention of the Principles of Operation is to introduce the basic function blocks that comprise the PCM power supply. For details on a specific circuit, consult Spellman's Engineering Department.

The PCM power supply is basically an AC to DC power converter. Within the power supply, conversions of AC to DC then to high frequency AC, then to high voltage DC take place.

Typical PCM power supplies comprise a few basic building blocks. These are: 1) AC to DC rectifier, 2) High frequency quasi-resonant inverter, 3) High voltage transformer and rectifier circuits, and 4) Control and monitoring circuits. The following is a brief description of each building block.

4.1 Power Factor and Associated Circuits

The PTV series can operate from 85VAC to 265Vac. The 1kV model are UL® rated for 85V to 250Vac input range.

The input voltage is connected via a typical IEC 320 type input connector. An internal EMI filter and fuse housing is an integral part of the IEC input module. The input circuits actively correct the power factor.

The input line voltage is applied to a current limit device to reduce the initial inrush current. The input line voltage is converted to a 400VDC voltage via an active PFC Converter.

WARNING

The energy levels used and generated by the power supply can be lethal! Do not attempt to operate the power supply unless the user has a sufficient knowledge of the dangers and hazards of working with high voltage. Do not attempt to approach or touch any internal or external circuits or components that are connected or have been connected to the power supply. Be certain to discharge any stored energy that may

be present before and after the power supply is used. Consult IEEE recommended practices for safety in high voltage testing #510-1983.

4.2 High Frequency Inverter

The PCM is a resonant converter operating in a zero current switching, series resonant, parallel loaded topology. MOSFET transistors switch the 400 VDC voltage to the resonant tank circuit. Typical operating frequency is in the range of 35-65KHz depending on model. Control of the resonant circuit output is done by the low voltage control circuits, and are isolated by an isolated pulse transformer. The output of the resonant circuit is applied to the primary of the high voltage transformer.

4.3 High Voltage Circuits

The high voltage transformer is a step-up type. The secondary of the high voltage transformer is connected to the high voltage rectifier circuit. The rectifier circuit will vary depending upon the rated output voltage. For lower output voltage, a full bridge or doubler circuit is used. For higher voltages, a half wave Cockcroft-Walton multiplier is used. A feedback signal is generated by the high voltage resistor divider. This feedback signal is sent to control circuits to provide voltage regulation and monitoring. A current sense resistor is connected at the low voltage end of the rectifier circuit. The circuit sense signal is sent to the control circuits to provide current regulation and monitoring.

The high voltage rectifier output is connected to an R-C type filter to reduce high frequency ripple components. The filter is then connected to the output limiting resistors. These resistors limit the peak surge current in the event an arc or discharge occurs. The limiting resistor output is connected to the output cable or connector provided.

4.4 Control Circuits

Control circuits are used for regulation, monitoring, pulse-width, control, slow-start and inhibit control. Feedback signals are calibrated and buffered via general purpose OP-AMPS. Pulse width control is accomplished by a typical PWM type control I.C. Logic enable/disable is provided by a logic gate I.C. Regulators generate +/- 15V and 10VDC.

WARNING

**LINE VOLTAGE IS PRESENT
WHENEVER THE POWER SUPPLY IS
CONNECTED TO EXTERNAL LINE
VOLTAGES. BE SURE TO DISCONNECT**

**THE LINE CORD BEFORE OPENING THE
UNIT. ALLOW 5 MINUTES FOR
INTERNAL CAPACITANCE TO
DISCHARGE BEFORE REMOVING ANY
COVER.**

4.5 Options

Due to the variations of models and options provided in the PCM series, details of actual circuits used may differ slightly from above descriptions. Consult Spellman's Engineering Department for questions regarding the principles of operations for the PCM series.

Chapter 5

OPTIONS

The options available for this power supply are described in this section. Interface diagrams are shown where required. Options are specified by including the option code in the model number as described in Section 1.4.

5.1 Floating Ground **FG**

The floating ground option allows isolation of the power supply common from chassis ground. A typical application for FG is for connection of an external meter or circuit into the FG signal point. This circuit can monitor actual current flow at a low voltage level. See Figure 5.1 for typical connection to the floating ground terminal.

IMPORTANT

The power supply common must be connected to chassis ground through a low impedance circuit. The power supply common is clamped to chassis ground using a power zener diode. This diode is not intended to clamp under continuous operation. On higher current units the power dissipation within the zener diode can be excessive if allowed to clamp.

5.2 No Slow Start **NSS**

The no slow start option causes the output voltage of the power supply to rise (within 50 msec) to the rated voltage upon Power Up.

5.3 Non-Standard Slow Start **SS(x)**

The non-standard slow start option allows the gradual rise time of the output voltage to be different from the standard of six seconds. To order the option, place the time desired in seconds after the suffix letter; i.e. SS(10) denotes a 10 second rise time.

5.4 Extra Length Output Cable **LL(ft)**

Standard output cable is 1 Meter long. Other lengths may be specified.

5.5 Focus Outputs

Focus outputs for CRT type applications can be provided. Generally, the focus output range is 6kV – 12kV, <1mA. Specific focus output requirements should be discussed with Spellman's sales department. Multiple focus, dynamic focus and variable focus control can also be provided.

5.6 Grid Outputs

Grid outputs for CRT type applications can be provided. Grid outputs can either be fixed or adjustable. Generally, grid outputs are in the ranges of a few hundred volts to 1800V, @ 1mA. Specific grid output requirements should be discussed with Spellman's sales department.

5.7 Custom Designed Models **X(#)**

Units built to customer specifications are assigned an X number by the factory. If this unit is an X model, specification control sheet is added at the end of this instruction manual.

5.8 Filament Outputs

Filament outputs with an emission control loop are available for use with X-Ray tubes. Generally, filament outputs are in the range of 3V – 12V, at currents up to 5A. Both AC and DC filaments are available.

Spellman welcomes the opportunity to tailor units to fit your requirements or to develop new products for your applications. Contact Spellman Sales Department.

Note: Before operating this system, refer to operating instructions in Chapter 3.

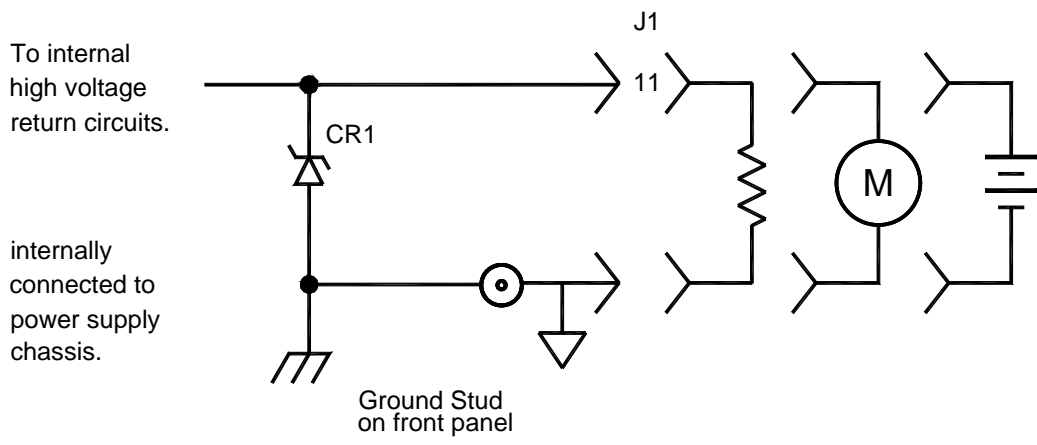

Figure 5.1 Floating Ground Interface Circuit

Chapter 6

MAINTENANCE

This section describes periodic servicing and performance testing procedures.

WARNING

THIS POWER SUPPLY GENERATES VOLTAGES THAT ARE DANGEROUS AND MAY BE FATAL.

OBSERVE EXTREME CAUTION WHEN WORKING WITH HIGH VOLTAGE.

6.1 Periodic Servicing

Approximately once a year (more often in high dust environments), disconnect the power to the unit and remove the top cover. Use compressed air to blow dust out of the inside of the unit. Avoid touching or handling the high voltage assembly.

6.2 Performance Test

WARNING

HIGH VOLTAGE IS DANGEROUS.

ONLY QUALIFIED PERSONNEL SHOULD PERFORM THESE TESTS.

High voltage test procedures are described in Bulletin STP-783, Standard Test Procedures for High Voltage Power Supplies. Copies can be obtained from the Spellman Customer Service Department. Test equipment, including an oscilloscope, a high impedance voltmeter, and a high voltage divider such as the Spellman HVD-100 or HVD-200, is needed for performance tests. All test components must be rated for operating voltage.

6.3 High Voltage Dividers

High voltage dividers for precise measurements of output voltage with an accuracy up to 0.1% are available from Spellman. The HVD-100 is used for voltages up to 100KV. The HVD-200 measures up to 200KV. The Spellman divider is designed for use with differential voltmeters or high impedance digital voltmeters. The high input impedance is ideal for measuring high voltage low current sources, which would be overloaded by traditional lower impedance dividers.

Chapter 7

FACTORY SERVICE

7.1 Warranty Repairs

During the Warranty period, Spellman will repair all units free of charge. The Warranty is void if the unit is worked on by other than Spellman personnel. See the Warranty in the rear of this manual for more information. Follow the return procedures described in Section 8.2. The customer shall pay for shipping to and from Spellman.

7.2 Factory Service Procedures

Spellman has a well-equipped factory repair department. If a unit is returned to the factory for calibration or repair, a detailed description of the specific problem should be attached.

For all units returned for repair, please obtain an authorization to ship from the Customer Service Department, either by phone or mail prior to shipping. When you call, please state the model and serial numbers, which are on the plate on the rear of the power supply, and the purchase order number for the repair. A Return Material Authorization Code Number (RMA Number) is needed for all returns. This RMA Number should be marked clearly on the outside of the shipping container. Packages received without an RMA Number will be returned to the customer. The Customer shall pay for shipping to and from Spellman.

A preliminary estimate for repairs will be given by phone by Customer Service. A purchase order for this amount is requested upon issuance of the RMA Number. A more detailed estimate will be made when the power supply is received at the Spellman Repair Center. In the event that repair work is extensive, Spellman will call to seek additional authorization from your company before completing the repairs.

7.3 Ordering Options and Modifications

many of the options listed in Chapter 5 can be retrofitted into Spellman power supplies by our factory. For prices and arrangements, contact our Sales Department.

7.4 Shipping Instructions

All power supplies returned to Spellman must be sent shipping prepaid. Pack the units carefully and securely in a suitable container, preferably in the original container, if available. The power supply should be surrounded by at least four inches of shock absorbing material. Please return all associated materials, i.e. high voltage output cables, interconnection cables, etc., so that we can examine and test the entire system.

All correspondence and phone calls should be directed to:

Spellman High Voltage Electronics Corp.

475 Wireless Boulevard

Hauppauge, New York 11788

TEL: (631) 630-3000 FAX: (631) 435-1620

E-Mail: sales@Spellmanhv.com

<http://www.spellmanhv.com>

To obtain information on Spellman's product warranty please visit our website at:

<http://www.spellmanhv.com/en/About/Warranty.aspx>

