

Keysight 8473B/C Detectors

Operating and
Service Guide

Notices

Copyright Notice

© Keysight Technologies 2014 - 2019
No part of this manual may be reproduced in any form or by any means (including electronic storage and retrieval or translation into a foreign language) without prior agreement and written consent from Keysight Technologies as governed by United States and international copyright laws.

Manual Part Number

08473-90003

Edition

Edition 5, January 16, 2019

Printed in:

Printed in Malaysia

Published by:

Keysight Technologies
Bayan Lepas Free Industrial Zone,
11900 Penang, Malaysia

Technology Licenses

The hardware and/or software described in this document are furnished under a license and may be used or copied only in accordance with the terms of such license.

Declaration of Conformity

Declarations of Conformity for this product and for other Keysight products may be downloaded from the Web. Go to <http://www.keysight.com/go/conformity>. You can then search by product number to find the latest Declaration of Conformity.

U.S. Government Rights

The Software is “commercial computer software,” as defined by Federal Acquisition Regulation (“FAR”) 2.101. Pursuant to FAR 12.212 and 27.405-3 and Department of Defense FAR Supplement (“DFARS”) 227.7202, the U.S. government acquires commercial computer software under the same terms by which the software is customarily provided to the public. Accordingly, Keysight provides the Software to U.S. government customers under its standard commercial license, which is embodied in its End User License Agreement (EULA), a copy of which can be found at <http://www.keysight.com/find/sweula>. The license set forth in the EULA represents the exclusive authority by which the U.S. government may use, modify, distribute, or disclose the Software. The EULA and the license set forth therein, does not require or permit, among other things, that Keysight: (1) Furnish technical information related to commercial computer software or commercial computer software documentation that is not customarily provided to the public; or (2) Relinquish to, or otherwise provide, the government rights in excess of these rights customarily provided to the public to use, modify, reproduce, release, perform, display, or disclose commercial computer software or commercial computer software documentation. No additional government requirements beyond those set forth in the EULA shall apply, except to the extent that those terms, rights, or licenses are explicitly required from all providers of commercial computer software pursuant to the FAR and the DFARS and are set forth specifically in writing elsewhere in the EULA. Keysight shall be under no obligation to update, revise or otherwise modify the Software. With respect to any technical data as defined by FAR 2.101, pursuant to FAR 12.211 and 27.404.2 and DFARS 227.7102, the U.S. government acquires no greater than Limited Rights as defined in FAR 27.401 or DFAR 227.7103-5 (c), as applicable in any technical data.

Warranty

THE MATERIAL CONTAINED IN THIS DOCUMENT IS PROVIDED “AS IS,” AND IS SUBJECT TO BEING CHANGED, WITHOUT NOTICE, IN FUTURE EDITIONS. FURTHER, TO THE MAXIMUM EXTENT PERMITTED BY APPLICABLE LAW, KEYSIGHT DISCLAIMS ALL WARRANTIES, EITHER EXPRESS OR IMPLIED, WITH REGARD TO THIS MANUAL AND ANY INFORMATION CONTAINED HEREIN, INCLUDING BUT NOT LIMITED TO THE IMPLIED WARRANTIES OF MERCHANTABILITY AND FITNESS FOR A PARTICULAR PURPOSE. KEYSIGHT SHALL NOT BE LIABLE FOR ERRORS OR FOR INCIDENTAL OR CONSEQUENTIAL DAMAGES IN CONNECTION WITH THE FURNISHING, USE, OR PERFORMANCE OF THIS DOCUMENT OR OF ANY INFORMATION CONTAINED HEREIN. SHOULD KEYSIGHT AND THE USER HAVE A SEPARATE WRITTEN AGREEMENT WITH WARRANTY TERMS COVERING THE MATERIAL IN THIS DOCUMENT THAT CONFLICT WITH THESE TERMS, THE WARRANTY TERMS IN THE SEPARATE AGREEMENT SHALL CONTROL.

Safety Information

CAUTION

A CAUTION notice denotes a hazard. It calls attention to an operating procedure, practice, or the like that, if not correctly performed or adhered to, could result in damage to the product or loss of important data. Do not proceed beyond a CAUTION notice until the indicated conditions are fully understood and met.

WARNING

A WARNING notice denotes a hazard. It calls attention to an operating procedure, practice, or the like that, if not correctly performed or adhered to, could result in personal injury or death. Do not proceed beyond a WARNING notice until the indicated conditions are fully understood and met.

Waste Electrical and Electronic Equipment (WEEE) Directive

This instrument complies with the WEEE Directive marking requirement. This affixed product label indicates that you must not discard this electrical or electronic product in domestic household waste.

Product category:

With reference to the equipment types in the WEEE directive Annex 1, this instrument is classified as a “Monitoring and Control Instrument” product.

The affixed product label is as shown below.



Do not dispose in domestic household waste.

To return this unwanted instrument, contact your nearest Keysight Service Center, or visit <http://about.keysight.com/en/companyinfo/environment/takeback.shtml> for more information.

Sales and Technical Support

To contact Keysight for sales and technical support, refer to the support links on the following Keysight websites:

- www.keysight.com/find/detectors
(product-specific information and support, software and documentation updates)
- www.keysight.com/find/assist
(worldwide contact information for repair and service)

THIS PAGE HAS BEEN INTENTIONALLY LEFT BLANK.

Table of Contents

Waste Electrical and Electronic Equipment (WEEE) Directive	3
Product category:	3
Sales and Technical Support	3
List of Figures	7
List of Tables	9
1 Introduction	
Overview	12
Description	12
Options	12
2 Specifications	
Product Specifications	14
Environmental Specifications	16
Physical Specifications	17
3 Installation, Operation, and Service	
Installation	20
Initial inspection	20
Mating connectors	20
Storage and Shipment	21
Environment	21
Original packaging	21
Operating information	22
Frequency response	23
Operator's checks	24
Performance Tests	26
Frequency response test	26
High level sensitivity test	27
Low level sensitivity test	27
Match test (SWR)	27

Adjustments	28
Service	28

List of Figures

Figure 3-1	Typical frequency response of the 8473B or 8473C detector	23
Figure 3-2	Peak power measurement	24

THIS PAGE HAS BEEN INTENTIONALLY LEFT BLANK.

List of Tables

Table 2-1	Product specifications	14
Table 2-2	Environmental specifications	16
Table 2-3	Physical specifications	17

THIS PAGE HAS BEEN INTENTIONALLY LEFT BLANK.

1 Introduction

Overview **12**

This chapter introduces the 8473B and 8473C crystal detectors and its available Options.

Overview

This manual contains operating instructions for the Keysight 8473B and 8473C Crystal Detectors. Included in the manual is the information required to install and test the crystal detector.

Description

The Keysight 8473B and 8473C crystal detector is a 50- Ω (nominal) device designed for measurement use in coaxial systems. The detector converts RF power levels applied to the 50- Ω input connector into proportional values of DC voltage. The RF input connector is a male APC 3.5 type connector (SMA compatible). The detector module uses a Low Barrier Schottky diode and thin film matching circuit that yield high sensitivity and broadband performance. The detector measures relative power up to 200 mW and has a BNC female connector for the output jack which allows the detected output to be connected to a SWR meter. The output voltage polarity is negative, unless Option 003 is selected. The frequency range is 10 MHz to 18 GHz for the 8473B, and 10 MHz to 26.5 GHz for the 8473C. Complete specifications for the crystal detectors are available in [Chapter 2](#), “Specifications,” starting on page 15.

Options

The crystal detector is available with the following options (see [Table 2-1](#) on page 14 for further descriptions):

Option 001:

Matched pair of detectors.

Option 002:

Square law load.

Option 003:

Positive polarity output.

2 Specifications

Product Specifications	14
Environmental Specifications	16
Physical Specifications	17

This chapter provides an overview specifications of Keysight 8473B/C crystal detector.

Product Specifications

Specifications are listed in [Table 2-1](#), [Table 2-2](#), and [Table 2-3](#). These specifications are the performance standards, or limits against which the instrument may be tested.

NOTE

RF may leak through the output connector, especially below 1 GHz. It can be reduced, if objectionable, with a suitable low-pass filter.

Table 2-1 Product specifications

	8473B	8473C
Frequency range (GHz)	0.01 to 18	0.01 to 26.5
Frequency response ^{[a] [b] [c]}	<ul style="list-style-type: none"> – ±0.2 dB over any octave to 8 GHz – 0.01 to 12.4 GHz: ±0.3 dB – 0.01 to 18 GHz: ±0.6 dB 	<ul style="list-style-type: none"> – ±0.2 dB over any octave to 8 GHz – 0.01 to 12.4 GHz: ±0.3 dB – 0.01 to 20 GHz: ±0.6 dB – 20 to 26.5 GHz: ±1.5 dB from a –3.3 dB linear slope.
Maximum operating input power	200 mW, peak or average	200 mW, peak or average
Maximum short term input power	1 watt (typical) peak or average for <1 minute	1 watt (typical) peak or average for <1 minute
Sensitivity ^{[a][d]}		
Low level <–20 dBm	>0.5 mV/μW	<ul style="list-style-type: none"> – 0.01 to 18 GHz: >0.5 mV/μW – 18 to 26.5 GHz: >0.18 mV/μW
High level	<0.35 mW produces 100 mV output	<–0.35 mW produces 100 mV output up to 18 GHz
SWR ^{[a] [b]}	<ul style="list-style-type: none"> – 0.01 to 4 GHz: 1.2 – 4 GHz to 18 GHz: 1.5 	<ul style="list-style-type: none"> – 0.01 to 4 GHz: 1.2 – 4 to 18 GHz: 1.5 – 18 to 26.5 GHz: 2.2
Input impedance	50 Ω (nominal)	50 Ω (nominal)
Output impedance ^[b]	1 to 2 KΩ (typically 1.3 KΩ) shunted by 20 to 60 pF (typically 30 pF)	1 to 2 KΩ (typically 1.3 KΩ) shunted by 20 to 60 pF (typically 30 pF)

Table 2-1 Product specifications (continued)

	8473B	8473C
Output polarity	Negative (refer to options for positive polarity units)	Negative (refer to options for positive polarity units)
Bias	Not required	Not required
Noise	<50 μ V p-p with CW applied to produce 100 mV output, 400 kHz bandwidth	<50 μ V p-p with CW applied to produce 100 mV output, 400 kHz bandwidth
Options		
001	Matched detector pair	Matched detector pair
Frequency response characteristics (exclusive of basic sensitivity) track within values listed to the right.	– 0.01 to 12.4 GHz: \pm 0.2 dB – 0.01 to 18 GHz: \pm 0.3 dB	– 0.01 to 12.4 GHz: \pm 0.2 dB – 0.01 to 18 GHz: \pm 0.3 dB – 0.01 to 26.5 GHz: \pm 0.5 dB
002	Square law load	Square law load
By choosing Option 002, the deviation from ideal square law response will be \pm 0.5 dB, although the sensitivity specification is decreased by a factor of 4.		
003	Positive polarity output	Positive polarity output

[a] Specifications given for +25° C unless otherwise noted.

[b] Measurement made at –20 dBm

[c] See [Figure 3-1](#) on page 21.

[d] Sensitivity decreases with increasing temperature, typically:

0.5 dB from –20° C to +25° C; 0.5 dB from +25° C to +40° C;
1 dB from +40° C to +55° C; 1.25 dB from +55° C to +75° C;
1 dB from +75° C to +85° C.

Environmental Specifications

Table 2-2 Environmental specifications

	8473B	8473C
Operating temperature	-20° C to +85° C	-20° C to +85° C
Humidity	<95% relative	<95% relative
Vibration	20 G from 80 to 2,000 Hz	20 G from 80 to 2,000 Hz
Shock	100 G for 11 ms	100 G for 11 ms
Altitude	4,570 m (15, 000 ft.)	4,570 m (15, 000 ft.)
Storage	<p>The instrument should be stored in a clean, dry environment. The following environmental limitations apply to both storage and shipment:</p> <ul style="list-style-type: none"> - Temperature: -54° C to +85° C - Humidity: <95% relative - Altitude: <7,620 meters (25,000 feet) - Shock: 100 G for 11 ms - Vibration: 20 G from 80 to 2,000 Hz 	

Physical Specifications

Table 2-3 Physical specifications

	8473B	8473C
Weight	Net 14 g (0.5 oz.)	Net 14 g (0.5 oz.)
Dimension	48 mm long, 10 mm diameter (1.9 in. long, 0.38 in. diameter)	48 mm long, 10 mm diameter (1.9 in. long, 0.38 in. diameter)

THIS PAGE HAS BEEN INTENTIONALLY LEFT BLANK.

3 Installation, Operation, and Service

Installation	20
Storage and Shipment	21
Performance Tests	26
Adjustments	28
Service	28

This chapter describes the installation and operating procedures for the crystal detectors. It also describes the available performance tests used for testing the detector specifications.

Installation

Initial inspection

Inspect the shipping container for damage. If the shipping container or cushioning material is damaged, it should be kept until the contents of the shipment have been checked for completeness and the instrument has been checked mechanically and electrically. The procedures for checking electrical performances are given under “Performance Tests” on page 26. If the contents are incomplete, if there is mechanical damage or defect, or if the instrument does not pass the electrical performance test, notify the nearest Keysight office. If the shipping container is damaged, or the cushioning material shows signs of stress, notify the carrier as well as the Keysight office. Keep the shipping materials for the carrier’s inspection. At Keysight’s option, the office will arrange for repair or replacement without waiting for claim settlement.

Mating connectors

The mating output connector used with the crystal detector must be a male BNC connector. The mating RF input connector must be a female APC 3.5 (SMA compatible) connector.

Storage and Shipment

Environment

The instrument should be stored in a clean, dry environment. Please see [Table 2-2](#) on page 16 for the list of environmental limitations.

Original packaging

Containers and materials identical to those used in factory packaging are available through Keysight offices. If the instrument is being returned to Keysight for servicing, attach a tag indicating the type of service required, return address, model number, and serial number. Also, mark the container **FRAGILE** to assure careful handling. In any correspondence, refer to the instrument by model number and serial number.

CAUTION

Static discharge can damage the detector module. A 100 pF capacitor (1.2 m [4 ft.] of coax cable) charged to 14 volts stores 10^{-8} joules, the maximum pulse rating of the detector module. Connect cables to test equipment and discharge the center conductor before connecting to the detector.

CAUTION

DO NOT NEEDLESSLY HANDLE DETECTOR MODULE USED IN CRYSTAL DETECTOR. Static electricity which builds up on a person, especially on a cold dry day, must never be allowed to discharge through the crystal detector. Avoid exposed leads to or from the crystal detector, since these are often touched accidentally.

Operating information

The crystal detector can be used as a demodulator to obtain a pulse envelope which can then be observed on an oscilloscope. It can also be used as a general purpose detector.

When using the detector with an oscilloscope, and the waveshapes to be observed have rise times of less than 5 ms, the coaxial cable connecting oscilloscope and detector should be as short as possible and shunted with a resistor. Ideally, this resistor should be 50 Ω to terminate the coaxial cable properly. However, with 50 Ω resistance, the output video pulse may be too small to drive some oscilloscopes. Therefore, the cable should be shunted with the smallest value of resistance that will obtain suitable deflection on the oscilloscope; typically the value will lie between 50 Ω and 2 K Ω . The larger the resistance the more degradation of rise time.

The power applied to the detector can be either modulated or continuous wave (CW). If modulated at a 1,000 Hz rate, an SWR meter can be used as an indicator. For CW detection, a DC milliammeter or millivoltmeter can be used as the indicator.

Frequency response

The thin film input matching circuit was optimized for flat frequency response, and low SWR which yields improved performance in leveling loops and power monitoring applications. Figure 3-1 shows the typical frequency response of the crystal detector.

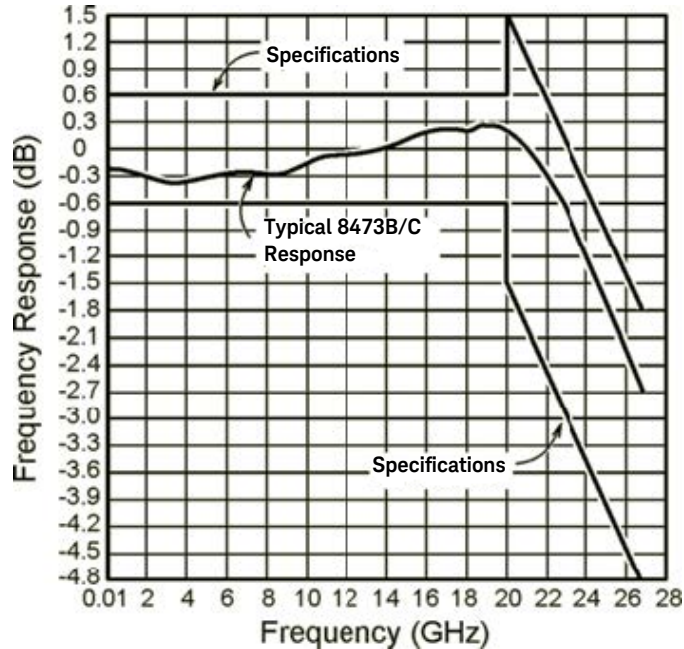

Figure 3-1 Typical frequency response of the 8473B or 8473C detector

Operator's checks

Peak power measurement

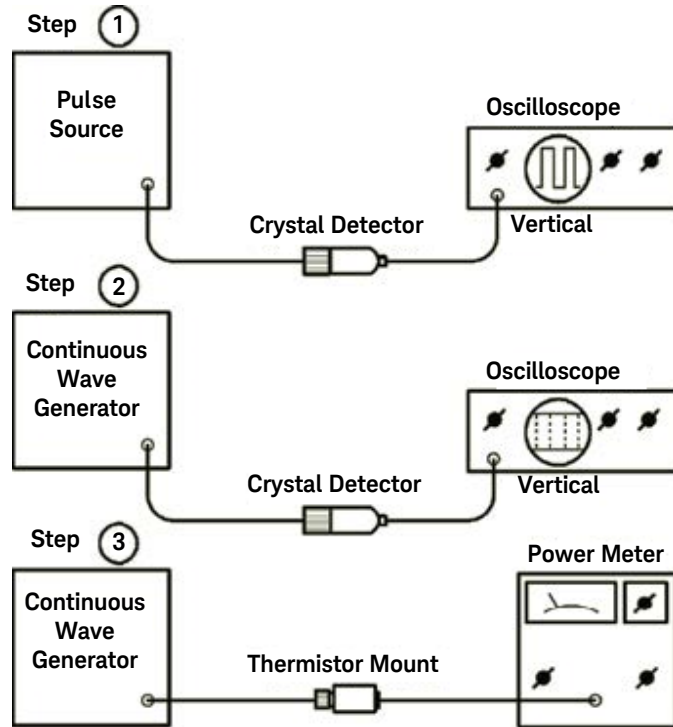

Figure 3-2 Peak power measurement

The arrangement of equipment for peak power measurement is shown in [Figure 3-2](#). The procedure involves calibration of an oscilloscope which, in turn, is used to calibrate a CW generator.

The output of the calibrated CW generator is measured with a power meter; the peak power of a pulse is thereby measured. The procedure is as follows:

- 1** Connect equipment as shown in [Figure 3-2](#), step 1. Observe pulse on a DC-coupled oscilloscope. Using a marking pencil, mark on the graticule the base-to-peak amplitude of the pulse envelope.
- 2** Replace the pulse source with a CW generator. While observing the oscilloscope trace, adjust amplitude of CW generator output to make detector output equal to that of the pulse generator, as indicated by markings on graticule (step 1).
- 3** Leave CW generator at setting obtained in step 2. Disconnect detector from CW generator. Connect output of CW generator to power meter. Measure adjusted levels (set in step 2) of CW generator output. The peak power of the pulse envelope observed in step 1 is equal to the output power of the CW generator.

Performance Tests

The following paragraphs suggest methods to use for testing detector specifications. For these tests refer to the manuals of the equipment involved for operating instructions.

Frequency response test

- 1 Using signal sources covering 10 MHz to 26.5 GHz with a 10 dB isolating attenuator and a power meter, connect power sensor to attenuator. Adjust RF power level to -20 dBm input to power sensor.
- 2 Without changing RF power level of signal source, disconnect power sensor.
- 3 Connect detector to attenuator. Measure DC voltage output from detector output from detector and record measurement.
- 4 Change frequency of signal source and repeat steps 1 through 3.
- 5 Since the detector follows a square-law response at this power level, it's output is proportional to power ($P_{dB} \propto 10 \log V_o$).
- 6 Total variation of detector readings should meet specifications (see [Table 2-1](#) on page 6) for all frequencies of interest across the band.

NOTE

Multiple mismatch errors caused by attenuator SWR, power sensor SWR, and detector SWR should be taken into account, as well as the accuracy of the indicator used to measure the detector output.

High level sensitivity test

Use a signal source at some convenient frequency between 10 MHz and 18 GHz and a DC voltmeter or oscilloscope as the indicator. Connect the detector to signal source and adjust RF power level for a 100 mV detected output from detector.

Disconnect detector from signal source and measure RF output level. The RF output level should be ± 0.35 mW.

Low level sensitivity test

Use a signal source covering 10 MHz to 18 GHz for the 8473B or 10 MHz to 26.5 GHz for the 8473C, a 10 dB attenuator, and a power meter. Connect attenuator to signal source and power sensor to attenuator. Adjust RF power level for -20 dBm output from attenuator. Verify the ambient temperature.

Disconnect power sensor from attenuator and connect detector.

Measure the DC voltage output from detector. The output should be >5.0 mV up to 18 GHz for the 8473B/C and >1.8 mV from 18 to 26.5 GHz for the 8473C at 25° C. Between 20° C and 30° C with -20 dBm input power and a high impedance video load the sensitivity slope is typically -0.04 dB/ $^\circ$ C.

NOTE

Multiple mismatch errors caused by attenuator SWR, power sensor SWR, and detector SWR should be taken into account, as well as accuracy of the indicator used to measure detector output.

Match test (SWR)

To verify the detector SWR specifications, use any system whose measurement accuracies for SWR (residual SWR) are known.

Adjustments

The detector has no internal adjustments.

Service

Additional maintenance information can be obtained from the local Keysight office.



This information is subject to change without notice. Always refer to the Keysight website for the latest revision.

© Keysight Technologies 2014 - 2019
Edition 5, January 16, 2019

Printed in Malaysia



08473-90003

www.keysight.com