



TiTan™ 10S Ion Pump



TECHNICAL SPECIFICATIONS

Element Type	CV	DI
Pumping Speed (l/s, Nitrogen)	10	8
Starting Pressure (mbar)	$\leq 1 \times 10^{-3}$	$\leq 1 \times 10^{-3}$
Lifetime (hours @ 10^{-6} mbar)	50,000	
Ultimate Pressure (mbar)	$< 1 \times 10^{-11}$	
Maximum Baking Temperature (°C)	250 / 450 (without magnets)	
Inlet Flange	DN 35 (2.75 in.) CFR	
Weight, kg (lbs)	6 (13)	

DIMENSIONAL DETAILS*

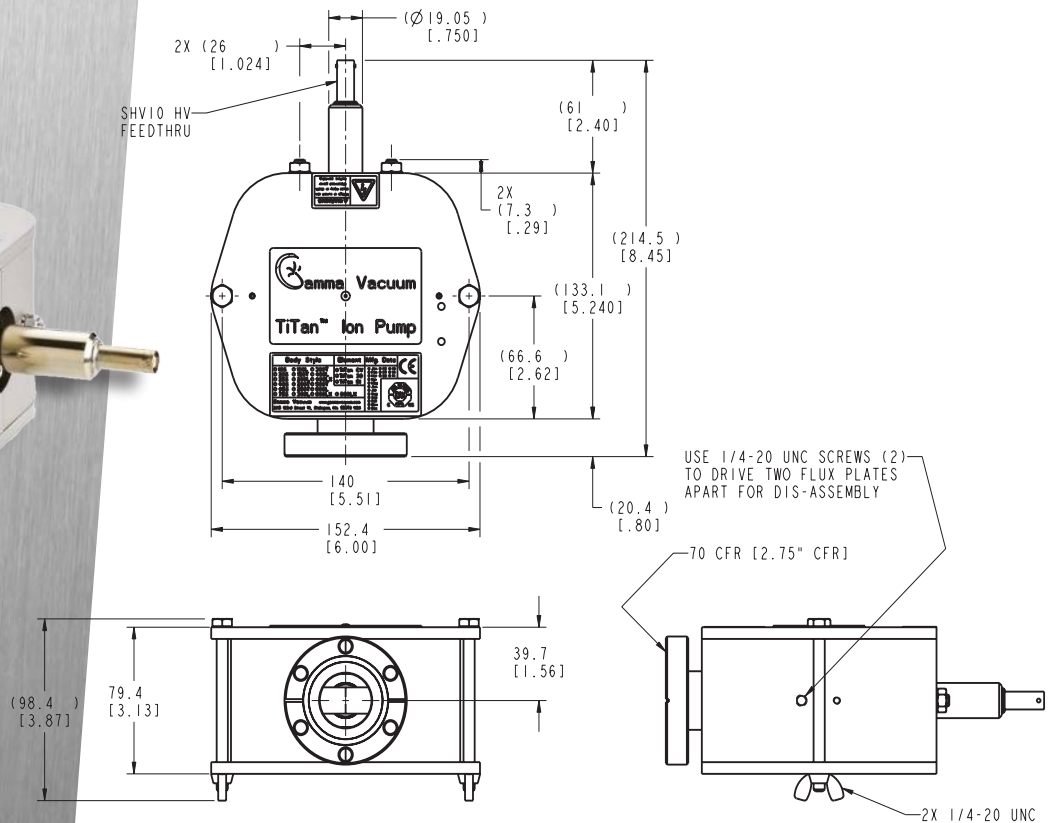

*Single inlet flange shown. Alternative configurations available at www.gammavacuum.com

STANDARD OPTIONS*

Element Styles		Ports		Feedthroughs		Heaters		TSP/NEG	
CV	Conventional 100% Titanium	2H	Single DN 35 (2.75 in. CFR) Horizontally oriented	SC	SAFECONN™ 10kV SHV	N	No Heaters	N	Not Available
DI	Differential 50% Titanium 50% Tantalum			OV	Old Varian	110	110-volt 90-130 nominal		
				FI	Fisher	220	220-volt 200-240 nominal		

*Configured part numbers and pricing are available at www.gammavacuum.com. Contact us directly for custom engineered options.

PERFORMANCE CHARACTERISTICS

Pumping Speed vs. Pressure

measured in accordance with ISO/DIS 3556-1.2-1192

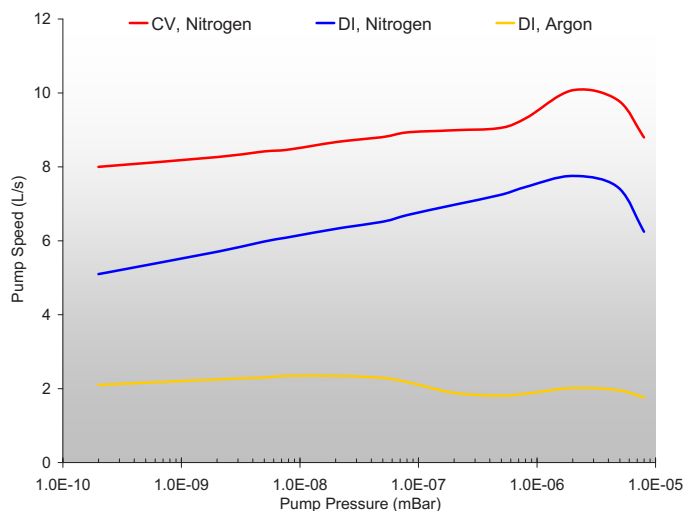

Current vs. Pressure

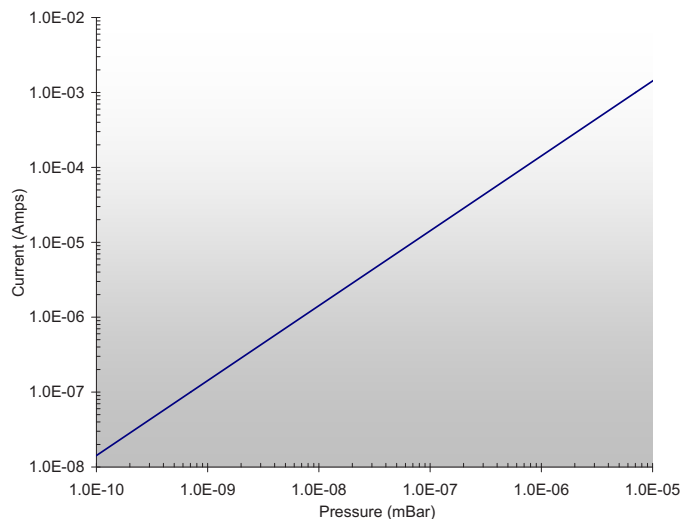

GAMMA VACUUM

2915 133rd Street West
Shakopee, MN 55379 | USA
800.237.3603 T | 952.445.4841 P
952.445.7615 F

gammavacuum.com | info@gammavacuum.com