

Rutherford experiment (Item No.: P2522115)

Curricular Relevance

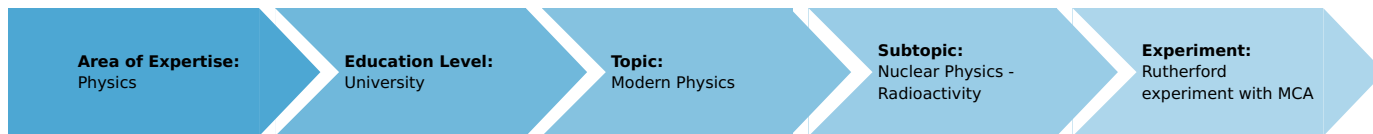

Difficulty



Difficult

Preparation Time



1 Hour

Execution Time



2 Hours

Recommended Group Size



2 Students

Additional Requirements:

- PC

Experiment Variations:

Keywords:

Scattering, angle of scattering, impact parameter, central force, Coulomb field, Coulomb forces, Rutherford atomic model, identity of atomic number, number of elementary charges on the nucleus

Overview

Short description

Principle

The relationship between the angle of scattering and the rate of scattering of α -particles by a gold foil is examined with a semiconductor detector. This detector has a detection probability of nearly one for α -particles and virtually no zero effect, so that the number of pulses agrees with the number of α -particles striking the detector.

Both a backscattering set-up for high angles of scattering and a forward scattering set-up for low angles of scattering are examined.

The influence of the atomic number of the scattering material is studied with gold ($Z = 79$) and aluminium ($Z = 13$).



Fig. 1: Experimental set-up

Equipment

Position No.	Material	Order No.	Quantity
1	Multichannel analyser	13727-99	1
2	measure Software multi channel analyser	14452-61	1
3	Alpha detector	09100-00	1
4	Annular diaphragm with gold foil	09103-02	1
5	Annular diaphragm with aluminium foil	09103-03	1
6	U-magnet, large	06320-00	1
7	Container for nuclear physics exp.	09103-00	1
8	Radioactive source Am-241, 370 kBq	09090-11	1
9	Pre-amplifier f.alpha detector	09100-10	1
10	Diaphragm pump, two stage, 220V	08163-93	1
11	Tubing connector, Y-shape, ID 8-9mm	47518-03	1
12	Pinchcock, width 20 mm	43631-20	1
13	Screened cable, BNC, l = 750 mm	07542-11	3
14	Vacuum gauge DVR 2, 1 ... 1000 hPa	34171-00	1
15	Vacuum tube, NBR, 6/14mm, 1 m	39289-00	2

Tasks

1. Relative particle rates are measured in a backscattering configuration in dependence on scattering angles between 110° and 145°. Scattering rates are compared between gold and aluminium as scattering specimen.
2. Particle rates are measured at different angles of scattering between 20° and 90° in a scattering geometry that compensates the angle dependence of the scattering rate in case of scattering probability proportional to the Rutherford scattering formula. Rates are compared to absolute rate predictions of the Rutherford scattering formula. For one specific angle scattering rates of gold and aluminium are compared.

Set-up and procedure Part1

Set-up

Fig. 1 shows the experimental set-up.

The α -detector is mounted on the inside of the flange cover of the vacuum vessel.

The short BNC cable is used to connect the flange cover to the "Detector" socket of the α -preamplifier. The other BNC cable connects the "Output" socket of the α -preamplifier with the "Input" socket of the MCA. The 5-pole cable connects the "+/- 12 V" jack of the MCA with the corresponding socket of the α -preamplifier.

The upper two preamplifier switches have to be set to " α " and "Inv.". The "Bias" switch has to be set to "Int." and the polarity switch for the internal bias must be kept to "-". Wrong polarisation of the detector diode is to be avoided!

Complete the electrical connections and preamplifier settings prior to turning on the MCA.

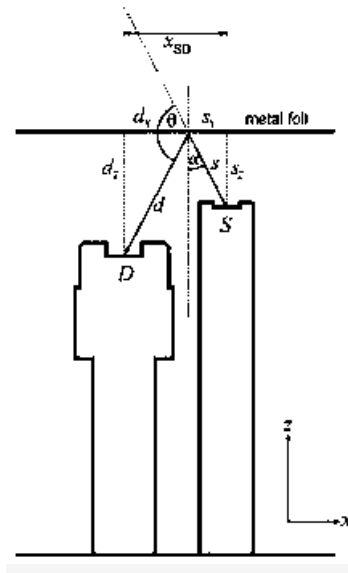

Fig. 2: Backscattering configuration and denotations

The MCA is connected by USB to a computer with "measure"- software installed on it. It may be necessary to remove a by "Windows" automatically installed USB driver and to install the correct USB driver for the MCA manually if the MCA is used with the computer for the first time.

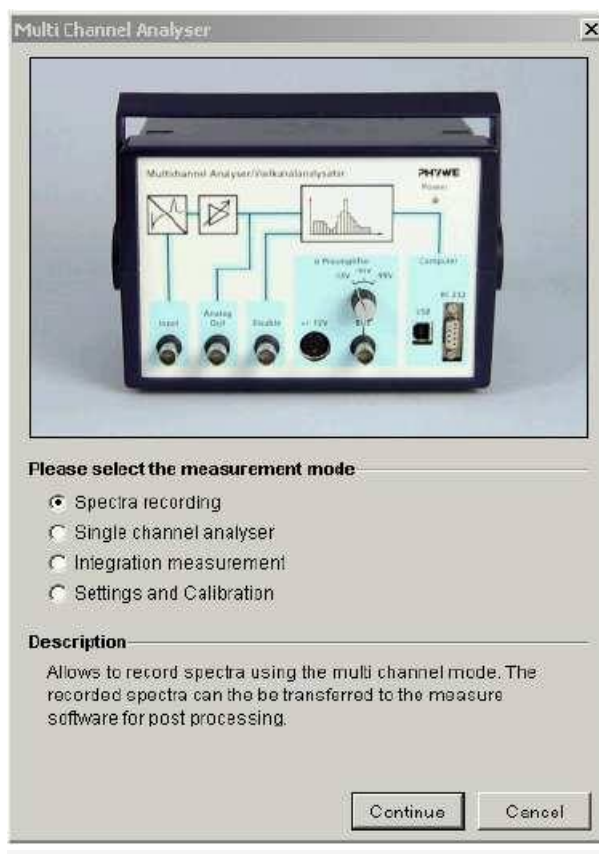

Fig. 3: Start window for the MCA

Task 1: Backscattering

The 370 kBq ²⁴¹Am source is mounted on the 5 mm thread on the inside of the flange cover beside the detector. The scattering specimen, the gold foil on annular diaphragm, is placed (the gold-foil side facing the source) inside the vessel. Be careful not to

touch the foil. See Fig. 2.

Procedure

Evacuate the vessel to a pressure below 20 hPa. Close the hose clamp before turning off the pump. Check the pressure to stay constant – no major leakage is to be present.

If using the Alpha- and Photodetector 09099.00, it is necessary to shield visible light from the detector e.g. with a piece of cardboard covering the vessel or by darkening the room.

Position the scattering foil with help of the magnet at scale reading 4.5 cm, that is 16 mm from the source rod's end. Start the "measure" program, select "Gauge" > "Multi Channel Analyser". Select "Spectra recording", use the "Continue" button, see Fig. 3.

Set "Gain" to "Level 2", "Offset [%]" to 6, select "Channel number" as x-data, press the "Reset" button and note down time of begin of measurement, see Fig. 4.

Wait until up to 100 impulses have been registered and note down time again. Calculate the impulse rate per minute and denote this value.

Repeat this measurement for scale position of the foil 4.0 cm, 5.0 cm, 5.5 cm, and 6.0 cm.

Exchange the gold with the aluminium foil. Measure the counting rate at 4.0 cm.

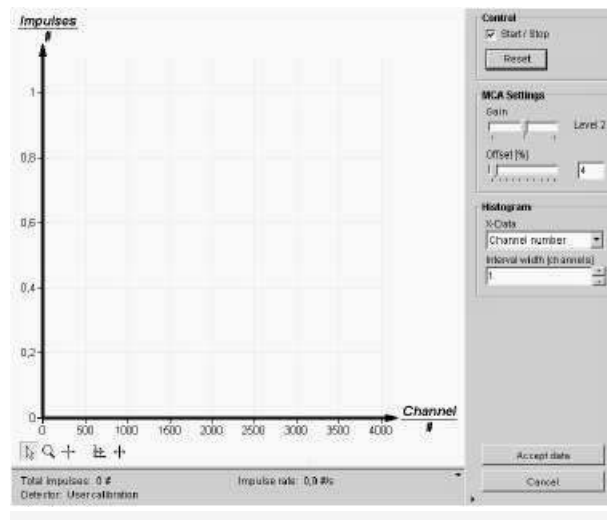

Fig. 4: Spectra recording window

Theory and evaluation Part1

Theory and evaluation

α -particles carry two positive elementary charges and four atomic mass units.

The interaction of energetic α -particles with matter can reveal information about the structure of atoms. Two facts seem to dominate the interaction:

- At high energies the α -particles lose their energy when passing matter proportional to path length and density of the crossed medium without major deflection. Most of them pass thin metal foils without being absorbed.
- Some of the α -particles undergo scattering at large angles. So assuming two main sorts of interaction may explain this behaviour. The energy loss proportional to path length with small deflection can be described by many interactions with light particles in each of which only small portions of energy and momentum of the α -particle are exchanged. The light particles may be dispersed uniformly throughout the medium and their density is proportional to the medium's mass density.
For a deflection through a large angle there has to be high momentum transfer in the interaction. The collision partner has to be heavier than an α -particle and has to be small since only few α -particles are deflected while most of them can pass a metal foil without deflection.
Rutherford described a model for this, the Rutherford scattering theory:
Atoms consist of
- light negatively charged electrons which fill all the space of the atom but carry only a very small fraction of it's mass
- and an extremely small heavy positively charged nucleus containing nearly all of the atom's mass with an electric charge equal to the atomic number balancing the charge of the electrons.
- The electrons shield the electric field of the nucleus so the atoms appear neutral to the outside but near the nucleus there is an electric Coulomb field decreasing with the inverse square of distance from the nucleus.

The particle rate $\Delta n(\Theta)$ of particles scattered through the angle Θ in a solid angle $d\Omega$ is governed under the above assumptions by Rutherford's scattering equation for α -particles:

$$\Delta n(\Theta) = n \cdot N \cdot d_F \cdot \left(\frac{1}{4}\right) \left(\frac{2Ze^2}{4\pi\epsilon_0 \cdot 2E_\alpha}\right)^2 \frac{d\Omega}{\sin^4 \frac{\Theta}{2}} \cdot (1)$$

in which

n = particle rate in the foil

N = atomic concentration in the foil

d_F = foil thickness

Z = nuclear charge of the scattering atoms

E_α = energy of the α -particles

e = elementary charge = $1.6021 \cdot 10^{-19} \text{ As}$

ϵ_0 = electric constant = $8.8524 \cdot 10^{-12} \text{ As/Vm}$

z/cm	$\alpha/^\circ$	$\Theta/^\circ$	r^2/cm^2	$n(z)$	t/min	$\Delta n(z)/\text{min}^{-1}$	$1/\sin^4(\Theta/2)$	$\Delta n(z) \cdot r^2 \cdot \sin^4(\Theta/2)$
4.0	34.9	110	16.2	138	23	6.0	2.21	44
4.5	28.1	124	23.8	153	51	3.0	1.65	43
5.0	23.5	133	33.4	116	59	2.0	1.41	46
5.5	20.0	140	45.0	143	111	1.3	1.28	45
6.0	17.5	145	58.6	53	53	1.0	1.21	48

Since the solid angle $d\Omega$ of the detector decreases with $r^{-2} = (s + d)^{-2}$, it can be assumed that mainly the particles with the shortest path from source S to detector D contribute to the counting rate. For the shortest path the angle of incidence equals the angle of reflexion, thus

$$\tan \alpha = s_x/s_z = d_x/d_z = x_{SD}/(d_Z + s_Z)$$

and

$$r = s + d = x_{SD}/\sin(\alpha)$$

with

$$x_{SD} = d_x + s_x = 2.3 \text{ cm fixed by the set-up.}$$

As the measured energy spectra show, the energy of the scattered particles at the moment of wide-angle-scattering remains unspecified as the α -particles lose energy when passing through the foil. A particle found in the detector at low energy means that it was scattered somewhere deep in the foil and has lost most of its energy while passing through matter. And the scattering probability is strongly energy-dependent. The experiment integrates over both a range of energies and a range of angles. So the absolute scattering probability is not revealed in this set-up but the angular dependence can be explored if

- the assumption holds, that the scattering-after-passed-matter- relation is angle-independent

- the incidence reduction with inverse square of distance is taken into account.

An argument supporting this is the similarity of the spectra for different foil distances and thus different angles of incidence: If the incidence is more lateral, the average depth of scattering in the foil is lower, but the distance passed inside the foil by the particles remains the same.

In other words: With a source delivering α -particles of given energy the abundance of α -particles with a lower energy is determined by path length in matter and not by angle of incidence.

It would be possible to select a specific scattering energy in the set-up. This could be done by narrowing the energy window of the measured particles and making an assumption on how the α -particles lose their energy when passing matter thus determining the depth of scattering at given energy and angle. But the obtainable counting-rates would be too low with a source of an activity still safe to handle.

In a measurement example the source S was seated at scale reading 2.6 cm so $s_z = z - 2.6\text{ cm}$, the detector D was at 2.1 cm so $d_z = z - 2.1$ with scale reading of the position of the foil z . Then

$$\alpha = \arctan(x_{SD}/(d_z + s_z)) = \arctan(2.3\text{ cm}/(2 \cdot z - 4.7\text{ cm}))$$

$$r^2 = ((x_{SD}/\sin(\alpha))^2 = (2.3\text{ cm}/\sin(\alpha))^2$$

$$\Theta/2 = 90^\circ - \alpha$$

The number of incidents $n(z)$ was measured during t minutes yielding counting rates $\Delta n(z)$ per minute (see Table 1).

Figures 5 and 6 plot these results.

For checking the Z^2 -dependency of the scattering rate an aluminium foil was used in an equal geometry as the gold foil. The results match the expected rates within the high uncertainty due to low number of incidents.

Table 2: Comparison of measured rate at $z = 4.0\text{ cm}$ for gold foil, $1.5\mu\text{m}$ and aluminium foil, $8.0\mu\text{m}$ thick.

z/cm	$n(Z)$	t/min	$\Delta n(z)/\text{min}^{-1}$	Z	Z^2	$\Delta n(z)/Z^2/\text{min}^{-1}$	$\frac{\sqrt{n(z)}}{n(z)}$
4.0	138	23	6.0	79	6241	$0.96 \cdot 10^{-3}$	8.5 %
4.0	15	72	0.21	13	169	$1.2 \cdot 10^{-3}$	26 %

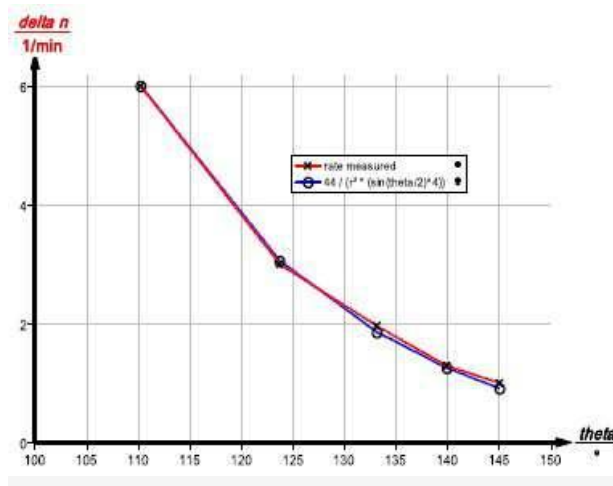

Fig. 5: Counting rate in dependence on scattering angle

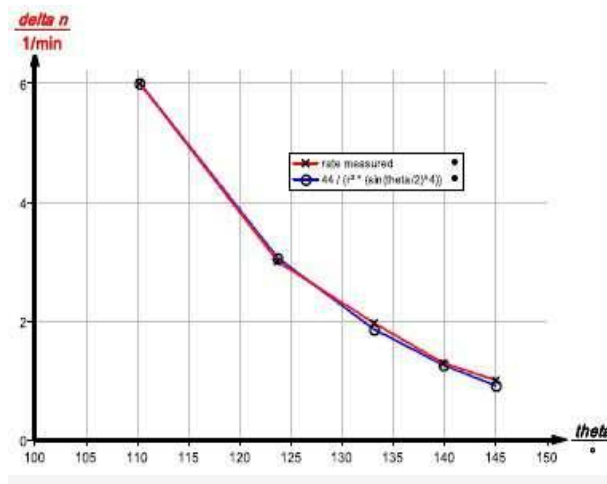

Fig. 6: Counting rate corrected for angle- and distancedependency

Set-up and procedure Part2

Set-up and procedure

Task 2: Forward scattering

Now change the set-up according to Fig. 7, using the gold foil diaphragm with the gold side facing the source.

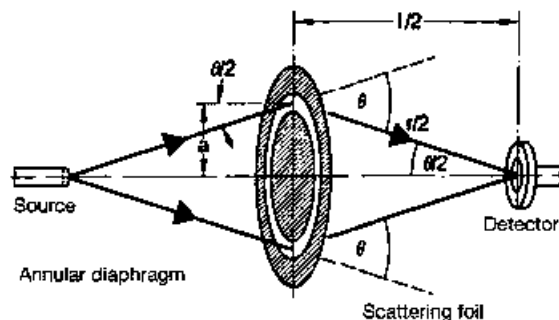

Fig. 7: Rutherford scattering set-up with annular foil

Evacuate the vessel as before, shield visible light from the detector, start the "measure" program, select "Gauge" > "Multi Channel Analyser". Select "Integration measurement", use "Continue" button. Set "Gain" to "Level 2", "Offset [%]" to 6 and "Recording time [s]" to 1800. Enter appropriate identifiers into the field "x-data", see Fig. 8. Adjust the distance l between detector and source with the sliding rod, fix it with the milled locking screw; adjust the gold foil position with help of the magnet halfway between detector and source. Begin with $l = 10$ cm. Use the "Measure" button. After the specified time has elapsed, a window as in Fig. 9 appears. Enter the used distance l and use the "Accept value" button. Alter the distance l keeping the diaphragm half-way between source and detector and use the "Perform measurement" button. Perform measurements for $l = 5, 7, 10, 14,$ and 19 cm, then use the "Accept data" button.

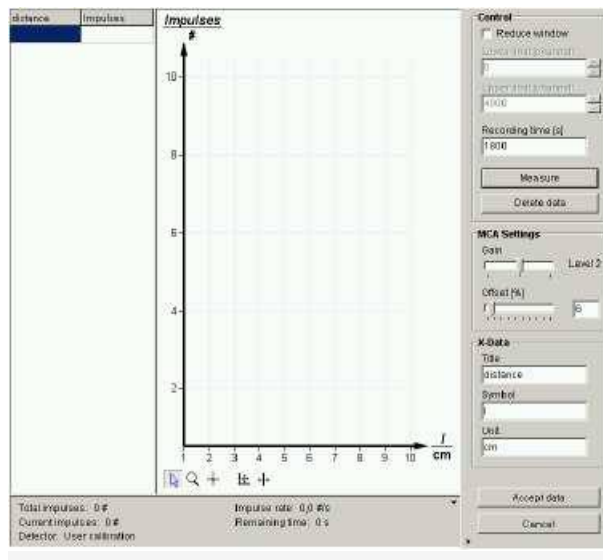

Fig. 8: Integration measurement window

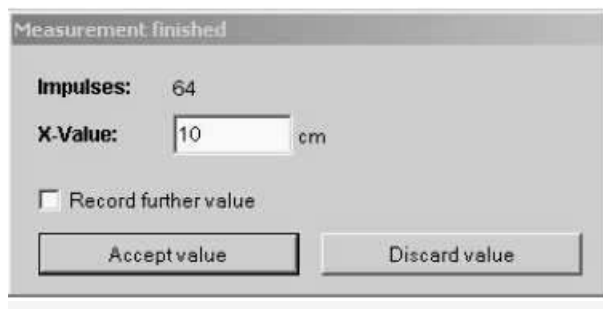

Fig. 9: Finished measurement window

The recorded data appear now in a window in the "measure" main program. Denote the measurement parameters using the "Display options" dialog and save the measurement data. Exchange the gold foil with the aluminium foil, evacuate the vessel and collect counts for $l = 10$ cm during 2400 s.

Theory and evaluation Part2

Theory and evaluation

Consider Fig. 10: The α -particle rate in the foil n decreases with r_1^{-2} as

$$n = \frac{Q}{4\pi r_1^2} \cdot A_F$$

with irradiated foil area A_F and the source activity (decay rate) Q if the source is assumed to be a point. The solid angle $d\Omega$ where particles get counted is determined by the distance between scattering foil and detector r_2 , the detector having sensitive area A_D , $d\Omega$ decreasing with r_2^{-2} as

$$d\Omega = \frac{A_D}{r_2^2}.$$

With the abbreviation

$$S = N \cdot \left(\frac{1}{4}\right) \cdot \left(\frac{2Ze^2}{4\pi\epsilon_0 \cdot 2E_\alpha}\right)^2 \quad (2)$$

the scattering equation becomes for the set-up of Fig. 7

$$\Delta n(\Theta) = \frac{Q A_F d_F}{4\pi r_1^2} \cdot \left(\frac{A_D}{r_2^2}\right) \cdot \left(\frac{S}{\sin^4\left(\frac{\Theta}{2}\right)}\right) \quad (3)$$

Fig. 7 shows a different geometric configuration, that is used in this experiment. Here the scattering foil is a ring of radius α midway between source and detector. Other particles not passing the foil are stopped by the screen that holds the foil and the scattering angle Θ is determined by the distance l between source and detector as

$$\Theta = 2 \cdot \arctan \frac{2\alpha}{l} \quad (4)$$

So in the scattering equation (2) have to be replaced:

- A_D by $A'_D = A_D \cos(\Theta/2)$
because the detector is seen under an angle and it's projection in direction of incidence is reduced;
- d_F by $d'_F = d_F / \cos(\Theta/2)$
because path length through the foil is increased for a particle crossing it at an angle
- A_F by $A'_F = A_F \cos(\Theta/2)$
because also the foil is seen under an angle by the particles and the effective foil area is reduced
- $r_1 = r_2$ by $r/2$
where r is the length of the particle's trajectory from source to detector.

Taking into account that

$$\sin(\Theta/2) = 2\alpha/r$$

so

$$\frac{1}{\sin^4(\Theta/2)} = \frac{r^4}{16\alpha^4},$$

the scattering equation (3) becomes

$$\Delta n(\Theta) = \frac{Q A_F d_F}{4\pi \left(\frac{r}{2}\right)^2} \cdot \left(\frac{A_D \cos(\Theta/2)}{\left(\frac{r}{2}\right)^2}\right) \cdot \left(\frac{S r^4}{16\alpha^4}\right) = \frac{Q A_F d_F S}{4\pi \alpha^4} \cdot A_D \cos(\Theta/2) \quad (4)$$

So if the scattering angle is increased by decreasing the distance between source and detector, the scattering rate decreases as $\sin^4(\Theta/2)$ but the rate of particles hitting the foil increases with $1/r^2$ and the solid angle of the detector increases with $1/r^2$, too. Altogether the geometry of the set-up compensates the $\sin^4(\Theta/2)$ -behaviour of the scattering probability. If the assumptions of Rutherford scattering hold, the particle rate becomes independent of source-detector distance except for a remaining factor $\cos(\Theta/2)$ from the direction dependency of the detector sensitivity. In practice the distance l should not go below 5 cm because the opening of the detector 09099.00 might otherwise shadow the sensitive area. The detector's sensitivity to α -particles reaching the sensitive area is nearly unity and the dark rate nearly zero. The offset is set such as to partly suppress multiple scattered α -particles which reach the detector with low energy or have left the source already with a low energy e.g. coming from a deeper layer or having undergone scattering already in the source. Because of the strong energy sensitivity of S it is questionable if they are to be taken into account.

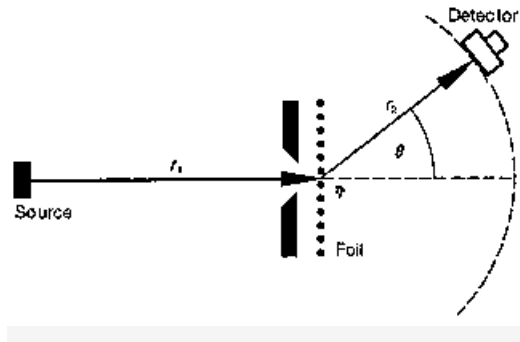

Fig. 10: Principle of Rutherford scattering measurement

You may obtain measurement results like the following measurement example:
With

$$Z(\text{gold}) = 79$$

$$N(\text{gold}) = 5.9 \cdot 10^{28} \text{ m}^{-3}$$

$$\epsilon_0 = 8.854 \cdot 10^{-12} \text{ As/Vm}$$

$$e = 1.602 \cdot 10^{-19} \text{ As}$$

$$E_a = 3 \text{ MeV} = 4.8 \cdot 10^{-13} \text{ J}$$

S becomes according to (2)

$$S = 21 \text{ m}^{-1}$$

and with

$$a = 20.16 \text{ mm} = 0.2016 \text{ m}$$

$$Q = 370 \text{ kBq} = 2.22 \cdot 10^7 \text{ min}^{-1}$$

$$A_F = 6 \text{ cm}^2 = 6 \cdot 10^{-4} \text{ m}^2$$

$$d_F = 1.5 \mu\text{m} = 1.5 \cdot 10^{-6} \text{ m}$$

$$A_D = 15 \text{ mm}^2 = 15 \cdot 10^{-6} \text{ m}^2 (\text{detector09099} - 00)$$

is according to (4)

$$\Delta n(\Theta) = 3.1 \cdot \cos(\Theta/2) \text{ min}^{-1}$$

Table 3: Forward scattering

l/cm	$\Theta/^\circ$	$n(l)$	$\Delta n(l), measured/min^{-1}$	$\Delta n(\Theta), theoretical/min^{-1}$
4	90.5	65	2.2	2.2
5	77.8	74	2.5	2.4
6	67.8	88	2.9	2.5
8	53.5	87	2.9	2.7
11	40.3	105	3.5	2.9
15	30.1	112	3.7	3.0
21	21.7	149	5.0	3.0

Fig. 11 shows a plot of these data.

Problems

There are three major systematic errors making the agreement of the measurement data with the Rutherford formula arbitrary:

- The assumed α -particle energy $E_\alpha = 3\text{MeV}$ is somewhat highhanded. ^{241}Am decay delivers $E_\alpha = 5.5\text{MeV}$, the mean α -energy of the covered source in use here is around 4 MeV but is already a broad distribution and after passing the 1.5 μm gold foil the mean energy is something below 3 MeV with the energy profile even broader. A fair calculation would have to fold the energy distribution in each foil layer with the scattering probability, since the predicted scattering rate is proportional to the inverse square of the α -energy and thus very sensitive to the energy.
- With the angle varies the foil thickness, which was taken into account, but also the energy of the particles due to stronger deceleration after longer path through matter, which was omitted. For angles greater 75° or l below 6 cm this leads to higher counting rates which you will measure if you reduce the offset that cuts the low-energy incidents e.g. to 1%.
- For low angles or high l also α -particles scattered by electrons are present which you can see by the strong rise of incidents in that range not predicted by the Rutherford formula at all.

The results are in the predicted order of magnitude, though. Also it can be seen that there is a mechanism deflecting high energy α -particles through high angles which can not be explained without the presence of a heavy particle in the atom.

Table 4: Comparison of scattering rates for $d_F = 1.5\mu\text{m}$ gold ($Z = 79$) and $d_F = 8\mu\text{m}$ Aluminium ($Z = 13$) for $l = 11\text{cm}, \Theta = 40.3^\circ, N(\text{aluminium}) = 6.0 \cdot 10^{28}\text{m}^{-3}$, other values as above

Z^2	$n(l)$	t/s	$N \cdot d_F/m^{-2}$	$\Delta n(l), measured/min^{-1}$	$\Delta n(\Theta), theoretical/min^{-1}$
6241	105	1800	$8.9 \cdot 10^{22}$	3.5	2.9
169	15	2400	$4.8 \cdot 10^{23}$	0.38	0.45

Table 4 shows a measurement example for the comparison of scattering at heavy and light elements. It can be seen that the scattering rate is lower for the element with lower atomic number. Since the aluminium layer thickness and particle density per area is higher, the mean α -particle energy is decreased compared to the situation with gold. One might expect thus a higher particle rate than predicted by theory. But the energy of the scattered particles may be that low that some of them have not been counted because their energy was below the offset. The error because of low number of incidents is as high as $\sqrt{n(l)}/n(l) = 26\%$. Still the measurement result is in the right order of magnitude.

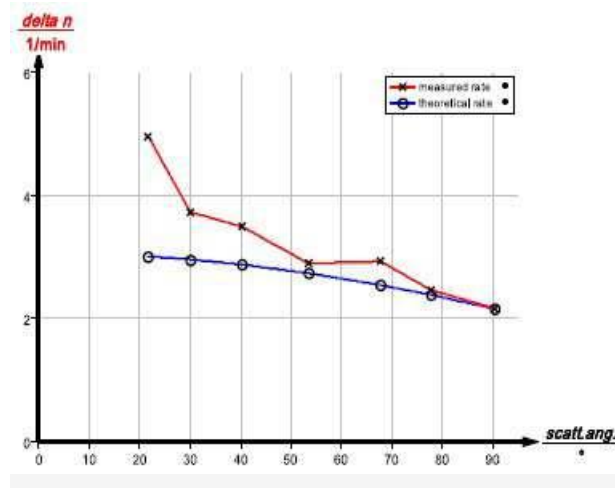

Fig. 11: Theoretical and measured scattering rate plotted over the scattering angle