

# Rectifier circuits (Item No.: P2440700)

## Curricular Relevance

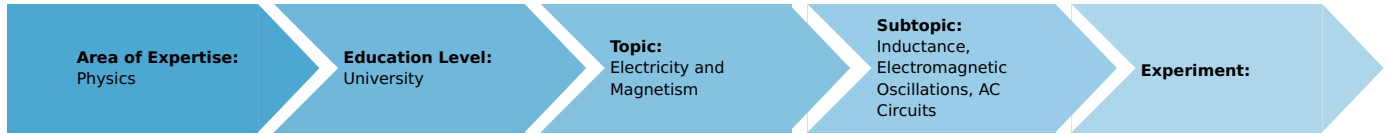

**Difficulty**



Difficult

**Preparation Time**



1 Hour

**Execution Time**



2 Hours

**Recommended Group Size**



2 Students

**Additional Requirements:**

**Experiment Variations:**

**Keywords:**

half-wave rectifier, full-wave rectifier, Graetz rectifier, diode, Zener diode, avalanche effect, charging capacitor, ripple, r.m.s. value, internal resistance, smoothing factor, ripple voltage, voltage stabilisation, voltage doubling

## Introduction

### Overview

The ripple of the output voltage of various rectifier circuits is measured as a function of the load current strength and the charging capacitance. The characteristics of a voltage stabilizer and of a multiplier are investigated.

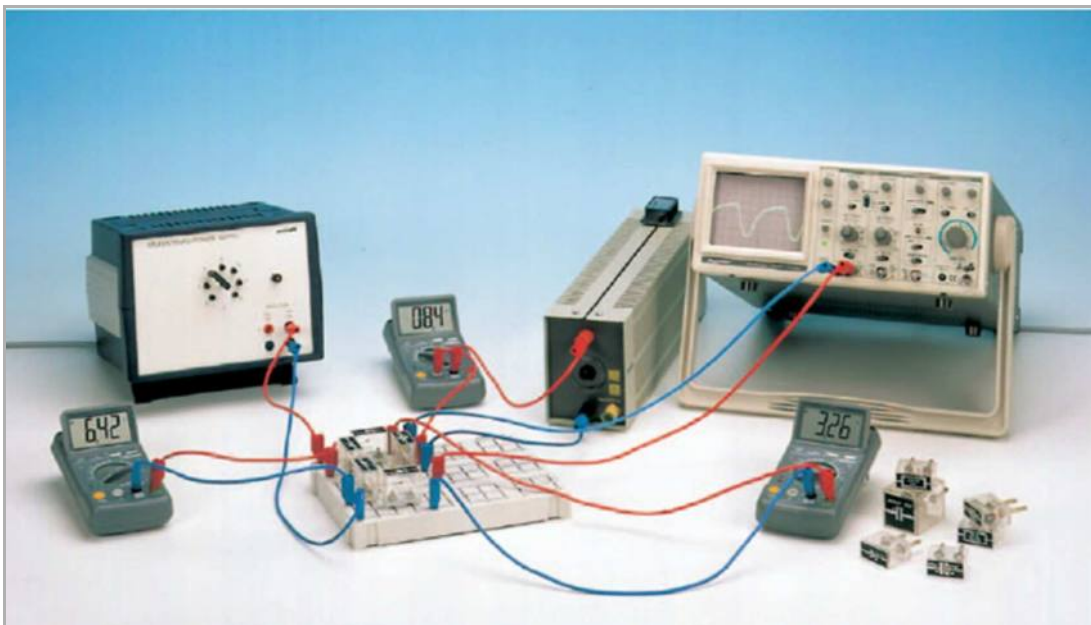

Figure 1: Bridge rectifier with voltage stabilization.

## Equipment

Position No.	Material	Order No.	Quantity
1	Plug-in board,4mm plugs	06033-00	1
2	Semiconduct.diode/si/1 N 4007,G1	39106-02	4
3	Electr.capaci. 470 microF/35V,G1	39105-26	1
4	Electrol.capacitor10microF/35V,G1	39105-28	4
5	Electrolyte capacitor 2000 $\mu$ F/35V, G2	39113-08	1
6	Capacitor,electr.1mF/35V,G1	06049-09	1
7	Resistor 470 Ohm, 1W, G1	39104-15	1
8	Resistor 47 Ohm, 1W, G1	39104-62	1
9	Low power zener diode ZF 4,7, G1	39132-01	1
10	PHYWE Multitap transformer, DC: 2/4/6/8/10/12 V, 5 A / AC: 2/4/6/8/10/12/14 V, 5 A	13533-93	1
11	30 MHz digital storage oscilloscope with colour display,2 x BNC cables l = 75 cm incl.	11462-99	1
12	Digital multimeter 2005	07129-00	3
13	Rheostat, 330 Ohm , 1.0A	06116-02	1
14	Adapter, BNC-plug/socket 4 mm	07542-26	1
15	Short-circuit plug, white	06027-06	3
16	Connecting cord, 32 A, 250 mm, red	07360-01	2
17	Connecting cord, 32 A, 250 mm, blue	07360-04	2
18	Connecting cord, 32 A, 500 mm, red	07361-01	4
19	Connecting cord, 32 A, 500 mm, blue	07361-04	4

## Task

1. Using the half-wave rectifier:
  - a. to display the output voltage (without charging capacitor) on the oscilloscope
  - b. to measure the diode current  $I_D$  as a function of the output current strength  $I_o$  (with the charging capacitor)
  - c. to measure the ripple component  $U_{AC,pp}$  of the output voltage as a function of the output current ( $C = \text{constant}$ )
  - d. to measure the ripple as a function of the capacitance ( $I_o = \text{constant}$ )
  - e. to measure the output voltage  $U_0$  as a function of the input voltage  $U_i$  ( $I_0 = 0$ ).
2. Using the bridge rectifier:
  - a. to display the output voltage (without charging capacitor) on the oscilloscope
  - b. to measure the current through one diode,  $I_D$ , as a function of the output current  $I_o$  (with the charging capacitor)
  - c. to measure the ripple of the output voltage as a function of the output current ( $C = \text{constant}$ )
  - d. to measure the ripple as a function of the capacitance ( $I_o = \text{constant}$ )
  - e. to measure the output voltage as a function of the input voltage.
3. To measure the voltage at the charging capacitor,  $U_C$ , and the output voltage of a stabilized voltage source as a function of the input voltage  $U_i$ .
4. To measure the output voltage of a voltage multiplier circuit as a function of the input voltage.

## Set-up and procedure

Set up the experiment on the universal plug-board in accordance with Fig. 1 and the circuit diagrams in Figs. 2 to 5. The output current is varied by the load resistor  $R_L$ . Care should be taken that the current does not exceed the maximum permissible  $I_A$  through the silicon diodes.

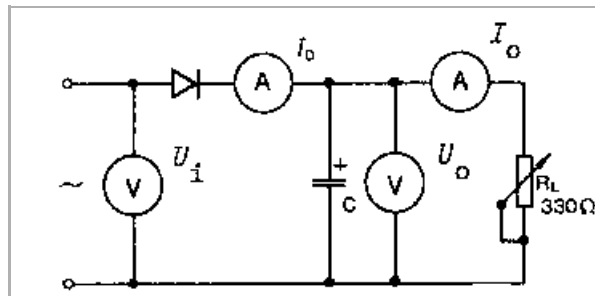

Fig. 2: Half-wave rectifier circuit.

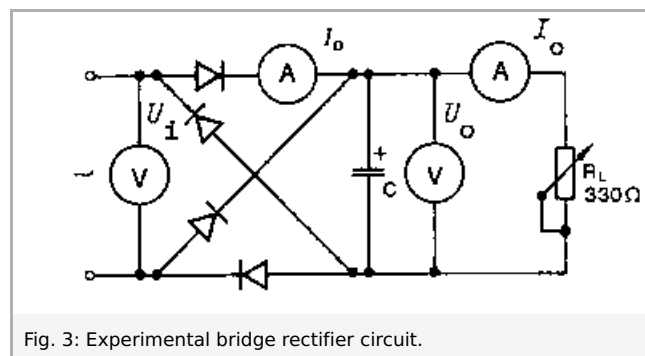

Fig. 3: Experimental bridge rectifier circuit.

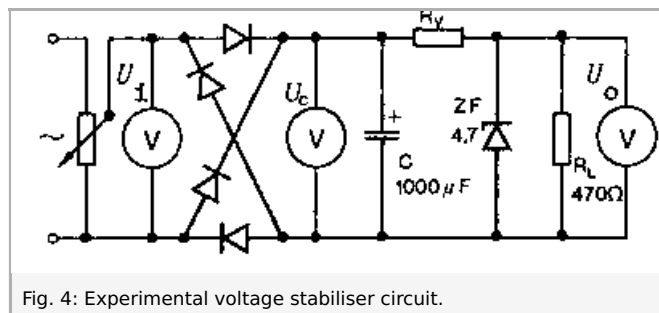

Fig. 4: Experimental voltage stabiliser circuit.

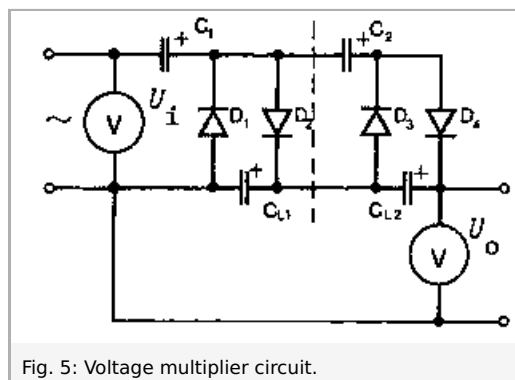
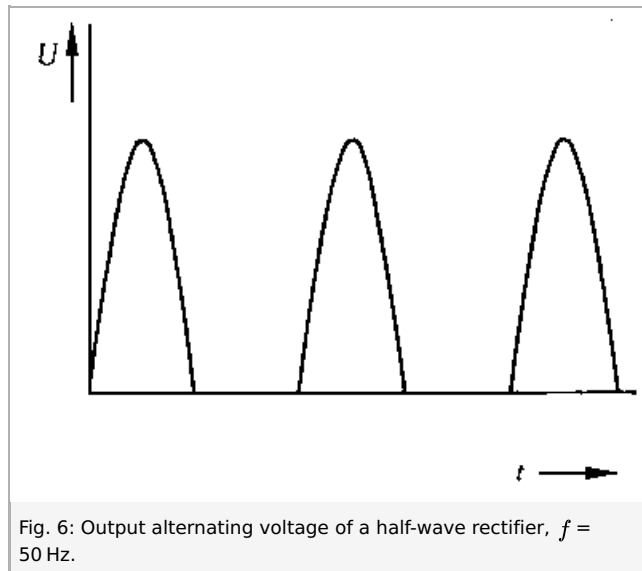

Fig. 5: Voltage multiplier circuit.



## Theory and evaluation

- In a half-wave rectifier (Fig. 2), only the positive half-waves of the input alternating voltage appear at the output, i.e. If there is no charging capacitor we obtain a pulsating direct voltage.

When the charging capacitor  $C$  is connected, it becomes charged to the peak value of the alternating voltage  $U_o = \sqrt{2} \cdot U_{i,rms}$  during the positive half-wave. As soon as the input voltage falls below the output voltage the diode blocks the circuit. The maximum inverse voltage at the diode is

$$U_{inv. max} = 2\sqrt{2}U_{i,rms}.$$

On load, the load resistor discharges the capacitor as long as the rectifier continues to block. The output voltage then consists of a direct voltage superimposed on an alternating voltage (ripple)  $U_{AC,pp}$ . The ripple amplitude is given by

$$U_{AC,pp} \sim \frac{I_0}{C \cdot f'}$$

where  $C$  is the charging capacitance and  $f'$  the frequency of the alternating voltage. The frequency of the ripple  $f'$  in the half-wave rectifier is  $f' = f = 50 \text{ Hz}$ .

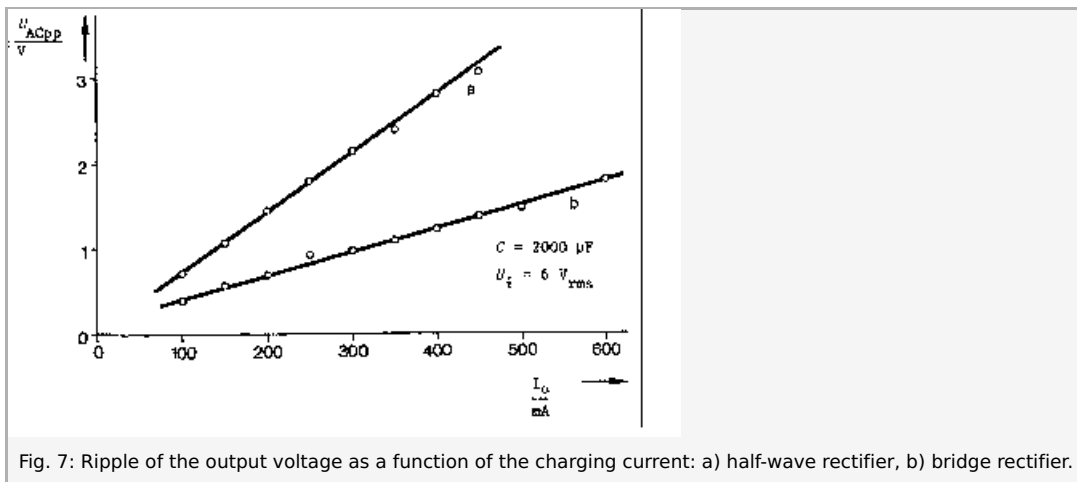

Fig. 7: Ripple of the output voltage as a function of the charging current: a) half-wave rectifier, b) bridge rectifier.

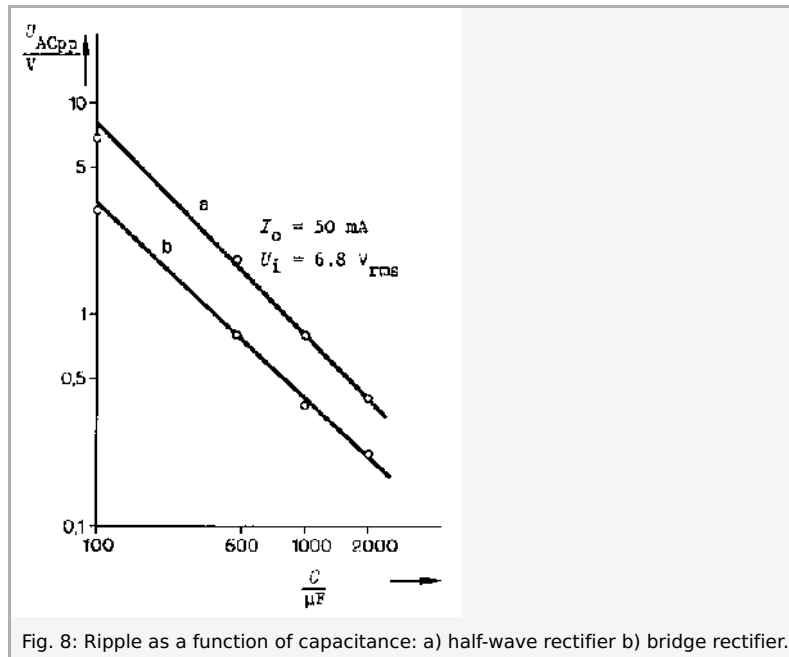

Fig. 8: Ripple as a function of capacitance: a) half-wave rectifier b) bridge rectifier.

Applying the expression

$$U_{AC,pp} = a \cdot C^b$$

to the measured values from Fig. 8, we obtain

$$b_1 = -0.89 \pm 0.02 \text{ (bridge rectifier)}$$

and

$$b_2 = -0.94 \pm 0.04 \text{ (half-wave rectifier)}$$

This shows, within the limits of error, that ripple is inversely proportional to capacitance. (Note; the capacitance values given for electrolytic capacitors are subject to a tolerance of  $-10\%$  to  $+50\%$ )

For the half-wave rectifier on no-load the output voltage is

$$U_o = \sqrt{2}U_{i,rms} - U_D$$

where  $U_D$  is the forward voltage of the diode (between  $0.5\text{ V}$  and  $0.8\text{ V}$  in the case of silicon diodes).

From the regression lines and measured values in Fig. 9 we obtain the following, using the expression:

$$U_o = a + bU_{i,rms}$$

Half-wave rectifier:

$$a = -0,6\text{ V} \Rightarrow U_D = (0.6 \pm 0.1)\text{ V}$$

$$s_a = 0.1\text{ V}$$

$$b = 1.45$$

$$s_b = 0.01$$

Bridge rectifier

$$a = -1.1\text{ V} \Rightarrow U_D = (0.55 \pm 0.05)\text{ V}$$

$$s_a = 0.1\text{ V}$$

$$b = 1.45$$

$$s_b = 0.01$$

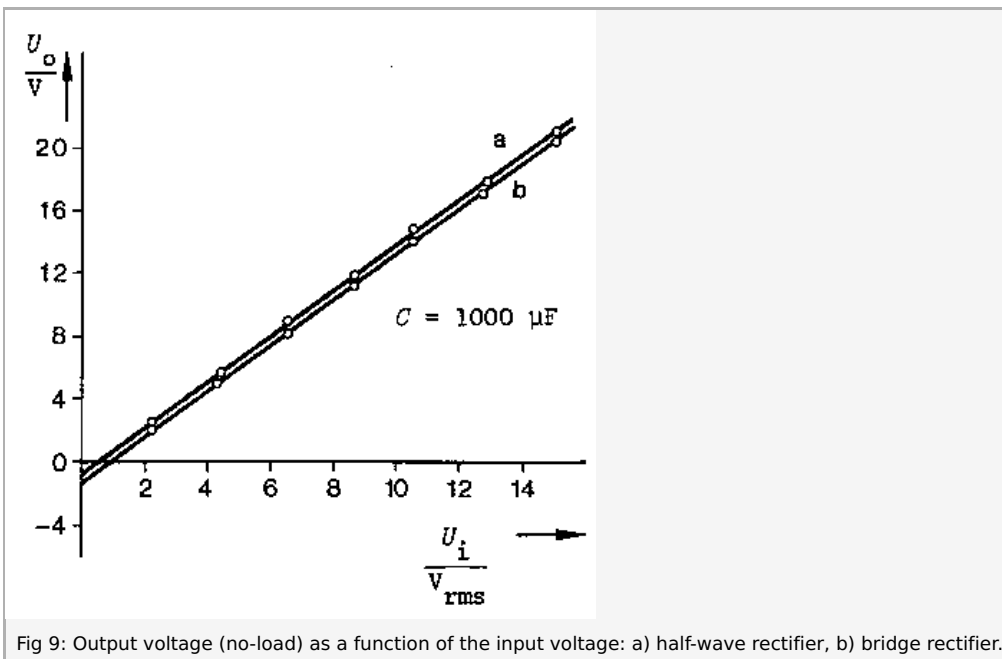

Fig 9: Output voltage (no-load) as a function of the input voltage: a) half-wave rectifier, b) bridge rectifier.

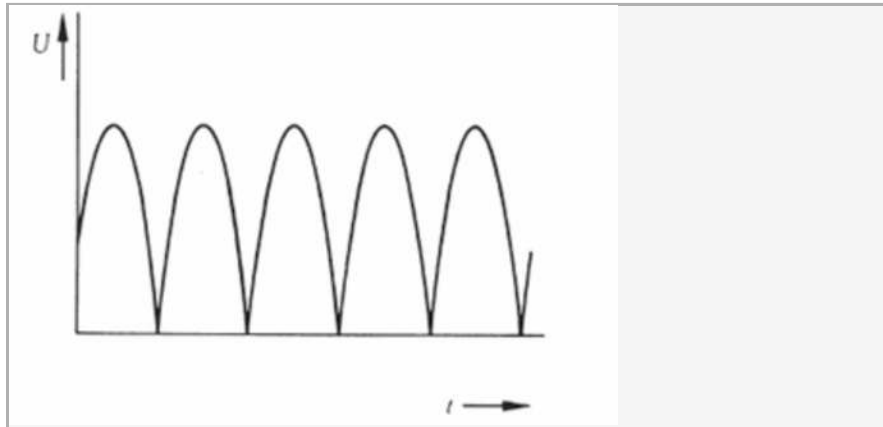

Fig 10: Output voltage of the bridge rectifier (without charging capacitor), frequency 100 Hz.

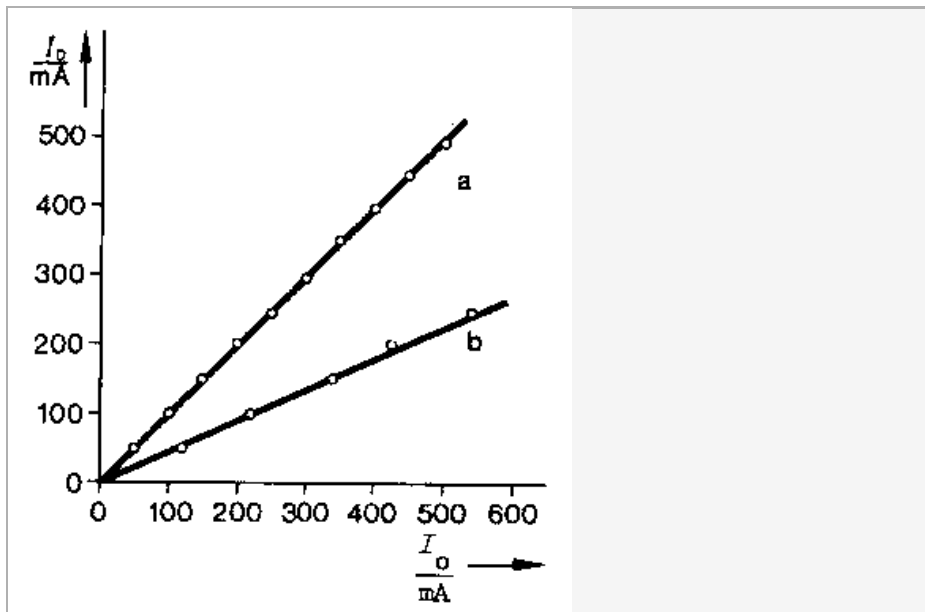

Fig 11: Diode current as a function of the output current: a) half-wave rectifier, b) bridge rectifier.

2. In full-wave rectification in the bridge circuit (Graetz rectifier), the diodes connect the negative pole of the voltage source to earth and the positive pole to the positive pole of the capacitor. Every half-wave is thus utilised.

The maximum voltage at a diode is then

$$U_{inv. \max} = \sqrt{2}U_{i,rms}$$

Contrary to the action of the half-wave rectifier, the r.m.s. current flowing through a diode in a fullwave rectifier is half the output current as only one pair of diodes is switched in at any time during a half-cycle. Fig. 11 confirms this relationship:  $I_D = g(I_o)$  gives a straight line of gradient 1 in the case of a half-wave rectifier, but of gradient 0.5 in the case of a bridge rectifier.

$$U_{AC,pp} \sim \frac{I_o}{2C \cdot f}$$

The measured values in Fig. 7 and 8 confirm this. As two series-connected diodes are driven in the conducting direction in each half-wave, the output voltage

$$U_o = \sqrt{2}U_{i,rms} - U_D.$$

3. When Zener voltage is reached the inverse current of a Zener diode rises steeply. This characteristic is used to stabilize the voltage:

If  $U_C$  (Fig. 4) exceeds the Zener voltage of 4.7 V, the current increases to such an extent that the voltage at the diode remains almost constant because of the voltage drop over  $R_V$ . The stabilization factor (smoothing factor) can be obtained from the gradient of the  $U_Q$  curve (Fig. 12).

For a point above approx. 6 V we obtain

$$G = \frac{\Delta U_C}{\Delta U_o} = 13.$$

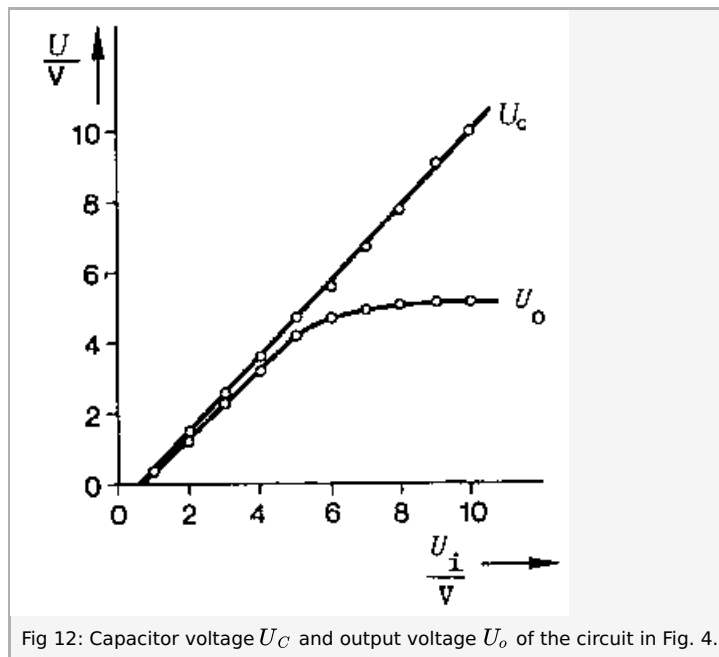

Fig 12: Capacitor voltage  $U_C$  and output voltage  $U_o$  of the circuit in Fig. 4.

4. Voltage multipliers are used to generate high voltages at low current consumption. The Greinacher rectifier (cascade connection) shown in Fig. 5 consists of  $n = 2$  cascades. Each stage generates a direct voltage  $U = 2 \cdot \sqrt{2} \cdot U_{i,rms}$  across  $C_L$ :  $n$  times the voltage thus reaches the capacitors arranged in series  $C_L$ .

For the unloaded voltage,  $U_o$ :

$$U_o = 2n\sqrt{2}U_{i,rms} - 2nU_D$$

Applying the regression expression  $U_o = a + b \cdot U_{i,rms}$  to the measured values in Fig. 13 we obtain:

$$a = -3.8 \text{ V} \Rightarrow U_D = (0.9 \pm 0.02) \text{ V}$$

$$s_a = 0.9 \text{ V}$$

$$b = 5.9 \Rightarrow n = 2.09 \pm 0.04$$

$$s_b = 0.1$$

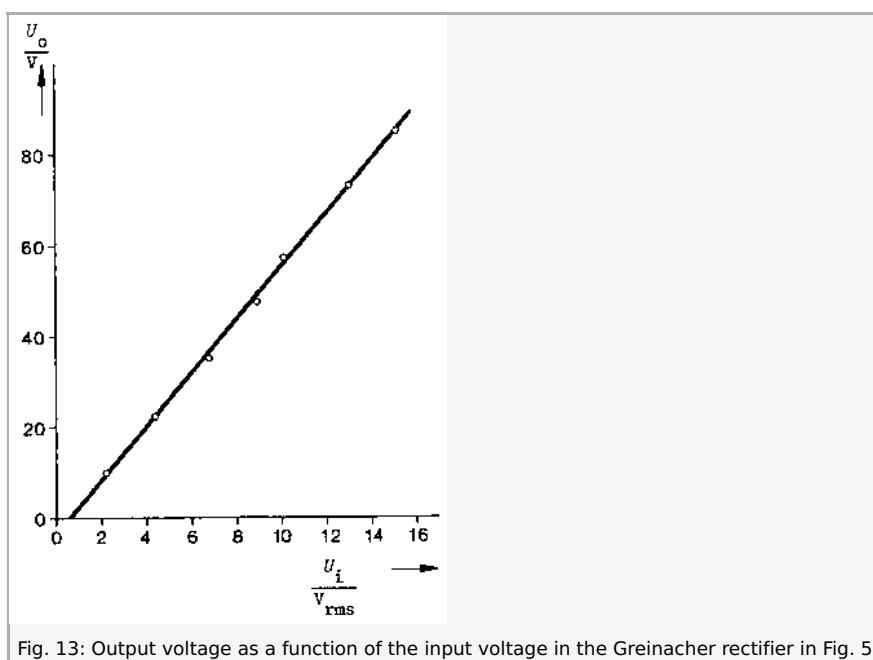

Fig. 13: Output voltage as a function of the input voltage in the Greinacher rectifier in Fig. 5



