

Capacitor in alternating current circuit with Cobra4

(Item No.: P2440564)

Curricular Relevance

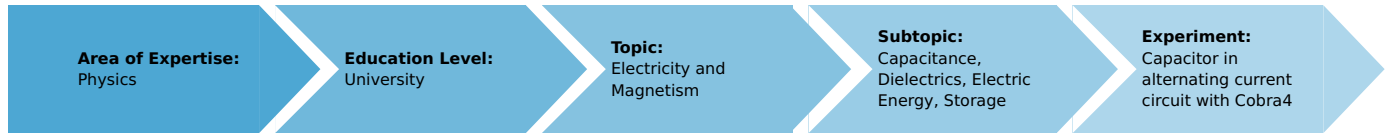

Difficulty



Difficult

Preparation Time



1 Hour

Execution Time



2 Hours

Recommended Group Size



2 Students

Additional Requirements:

Experiment Variations:

Keywords:

Capacitance, Kirchhoff's law, Maxwell's equations, AC impedance, Phase displacement

Overview

Principle

A capacitor is connected in a circuit with a variable-frequency voltage source. The impedance and phase displacement are determined as a function of frequency and of capacitance. Parallel and series impedances are measured.

Material

Position	Material	Bestellnr.	Menge
1	Cobra4 Xpert-Link	12625-99	1
2	Cobra4 Xpert-Link set of cables	12625-10	1
3	PHYWE Digital Function Generator, USB	13654-99	1
4	Connection box	06030-23	1
5	Capacitor 1 microF/ 100V, G2	39113-01	1
6	Capacitor 2,2microF/ 100V, G2	39113-02	1
7	Capacitor 4,7microF/ 100V, G2	39113-03	1
8	Resistor 47 Ohm, 1W, G1	39104-62	1
9	Resistor 100 Ohm, 1W, G1	39104-63	1
10	Resistor 220 Ohm, 1W, G1	39104-64	1
11	Software Cobra4 - multi-user licence	14550-61	1
Optional	Oscilloscope	EAK-P-1360	1

Tasks

1. Determine the impedance of a capacitor as a function of frequency.
2. Determine the total impedance of capacitors connected in series and in parallel.
3. Determine the phase displacement between current and voltage over a RC network as a function of frequency.

Set-up and procedure

Set-up

The basic set-up of the experiment is shown in fig. 1. Connect both, Xpert-Link and Digital Function Generator via USB with your computer. The Sync-output of the Function Generator gets connected with the T1 input of the Xpert-Link with a BNC cable and an adapter. Channel 3 (CH 3) of the Xpert-Link is connected with the connection box, so that it measures the voltage drop over the capacitor. The according connection diagram for the first measurement is shown in fig. 2. As output of the Function Generator the white and yellow jacks are used. Open measureLAB and load the settings for the experiment.

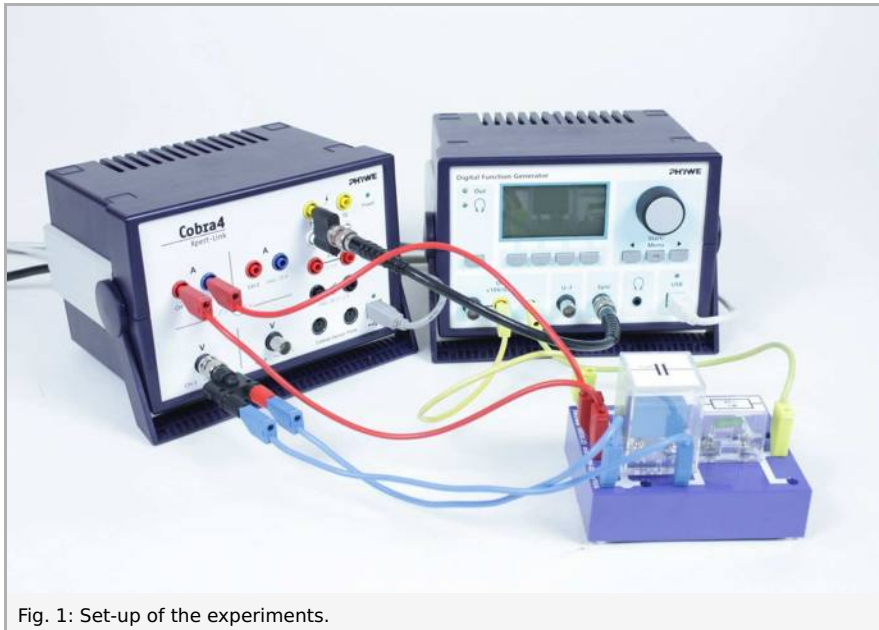

Fig. 1: Set-up of the experiments.

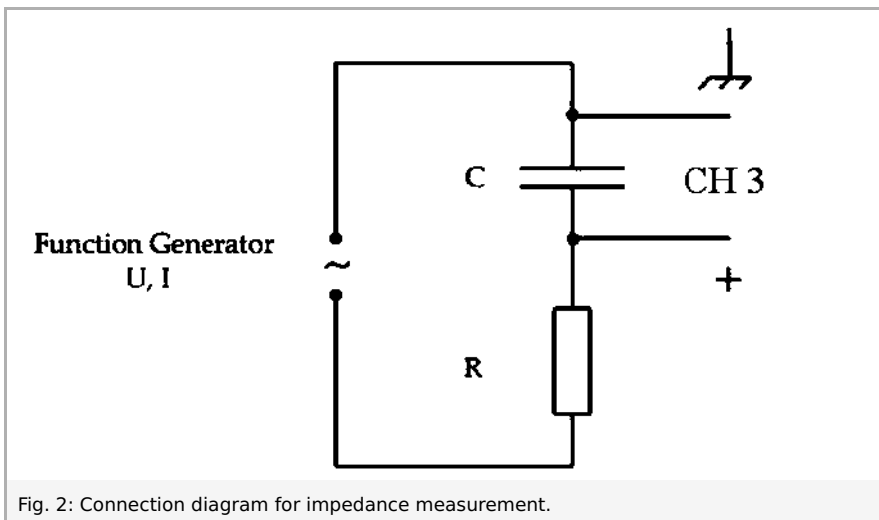

Fig. 2: Connection diagram for impedance measurement.

Impedance measurement

Open the Function Generator's settings and set them according to fig. 3. Then check if the settings of the Xpert-Link channels one and three (CH1 and CH3) are set to the parameters of fig. 4 and fig. 5. Set up two diagrams, which plot voltage and current against frequency of the Function Generator. This should result in curves as shown in fig. 6 and fig. 7. Record curves and datasets for different combinations of resistors and capacitors. Then export the datafiles for frequency, voltage and current for the different combinations and plot, for example with a spreadsheet, the impedance $Z = U/I$ against the period time $T = 1/f$ in one graph. An example is given in fig. 8. From the slope of the curves, the capacity can be determined as described in the theory chapter.

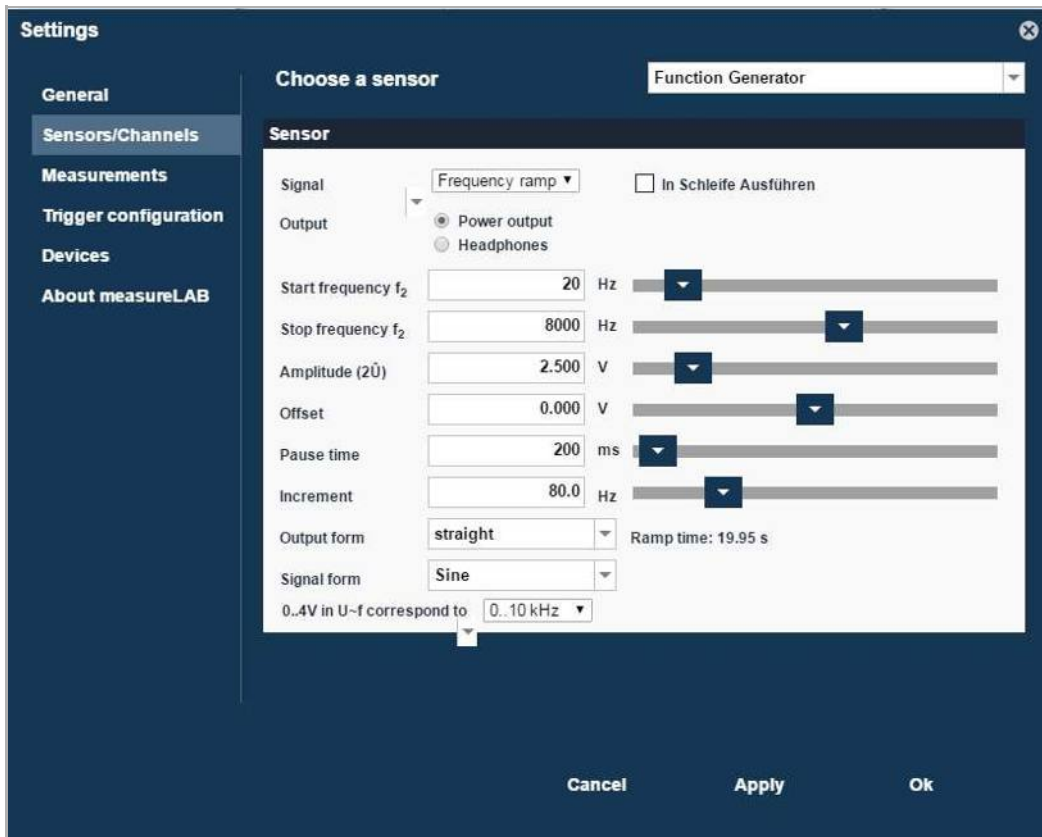

Fig. 3: Settings for the function generator

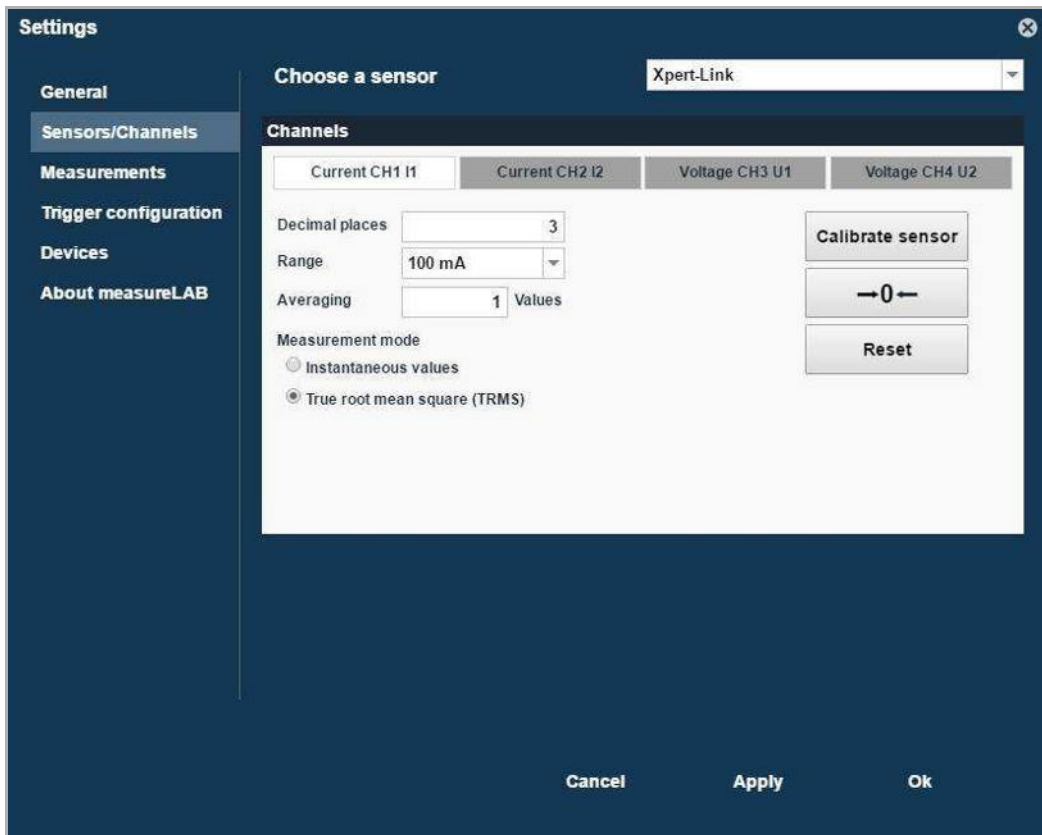

Fig. 4: Settings for channel 1.

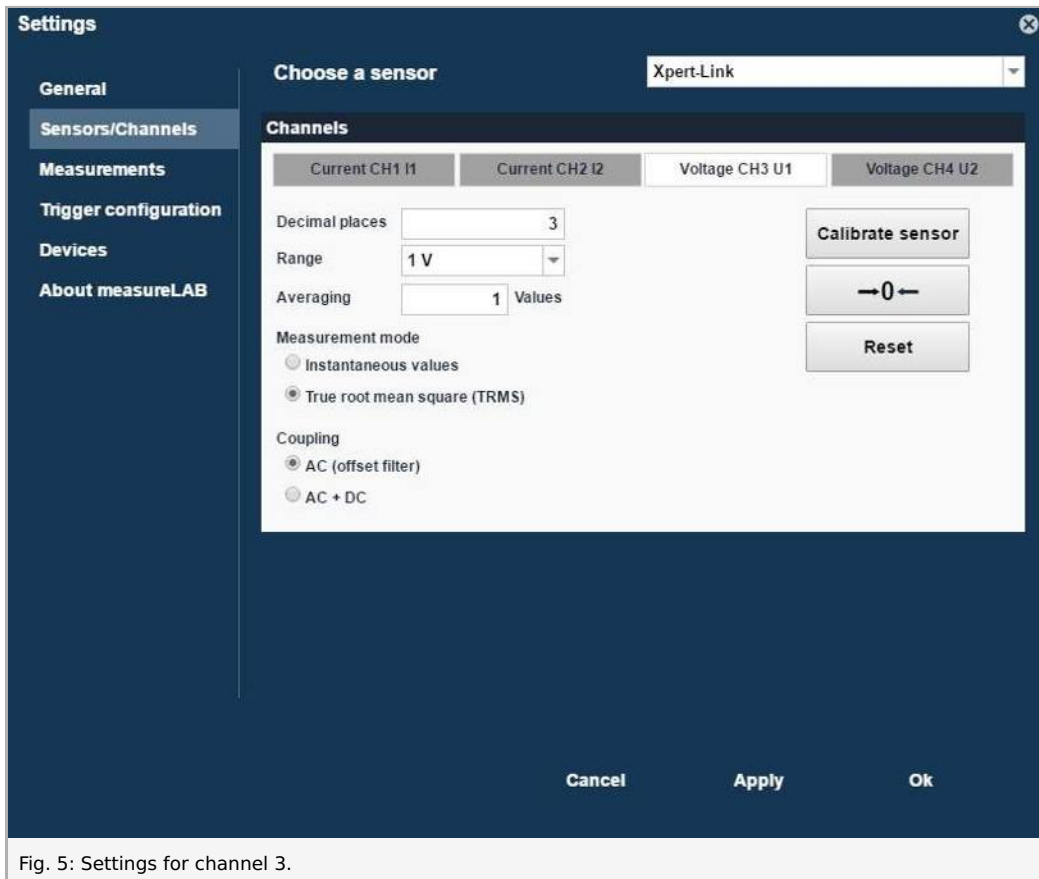

Fig. 5: Settings for channel 3.

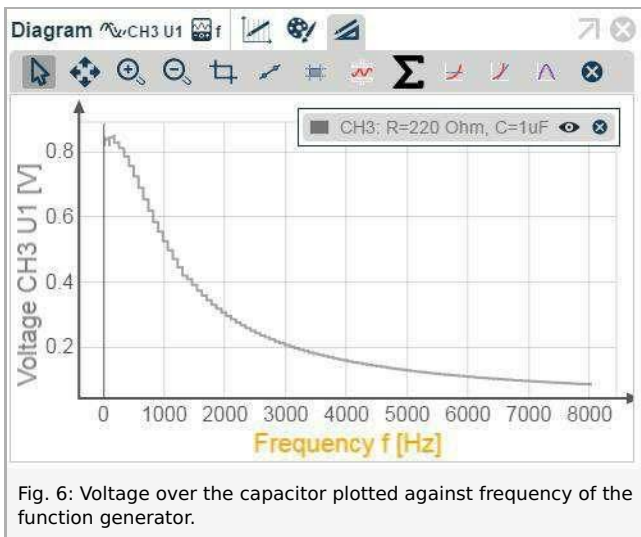

Fig. 6: Voltage over the capacitor plotted against frequency of the function generator.

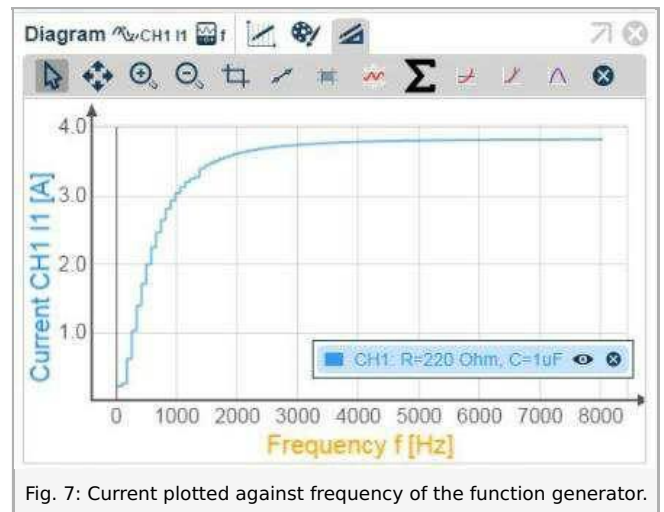
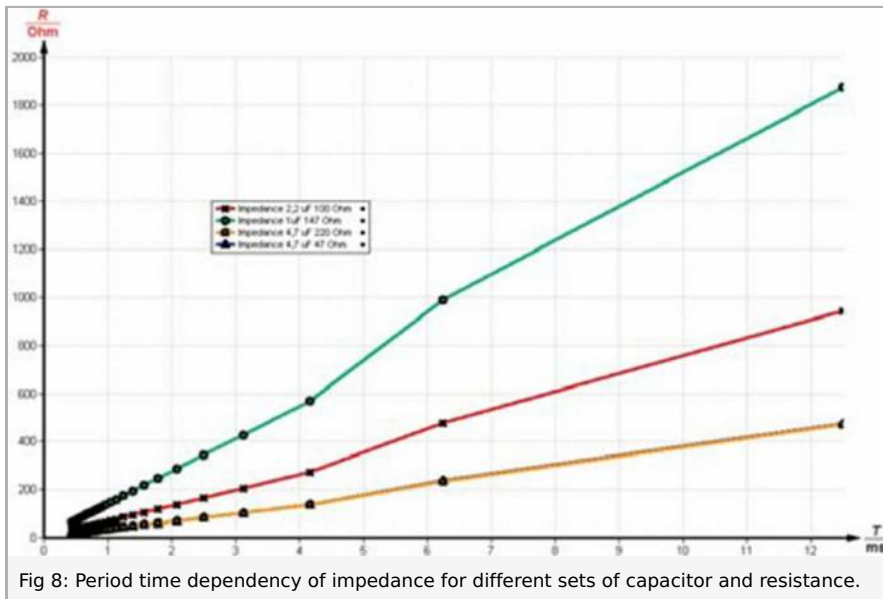
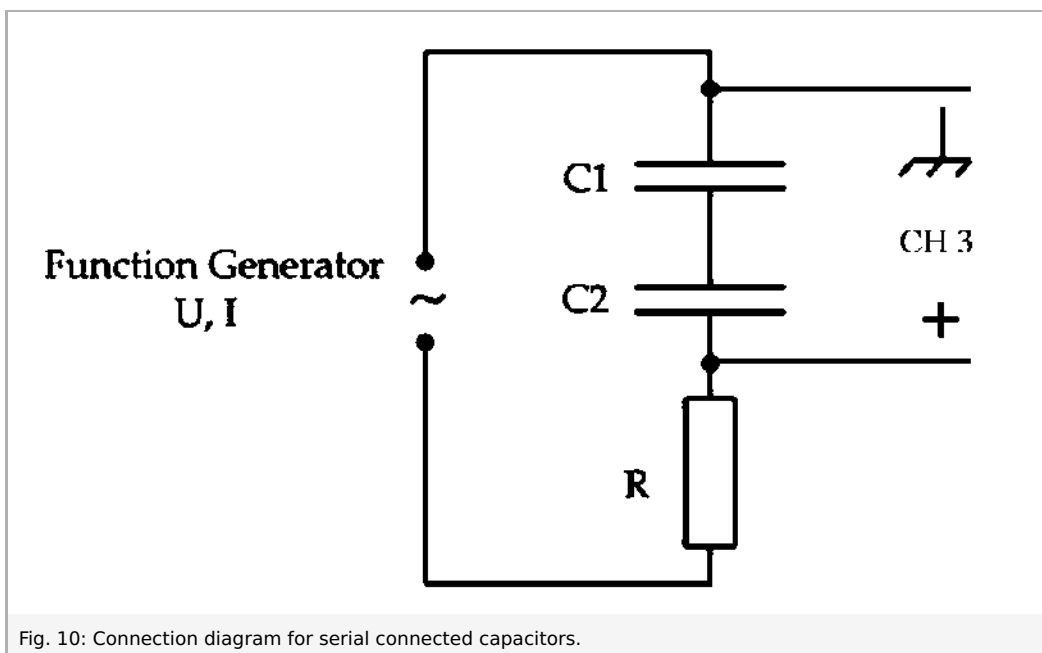
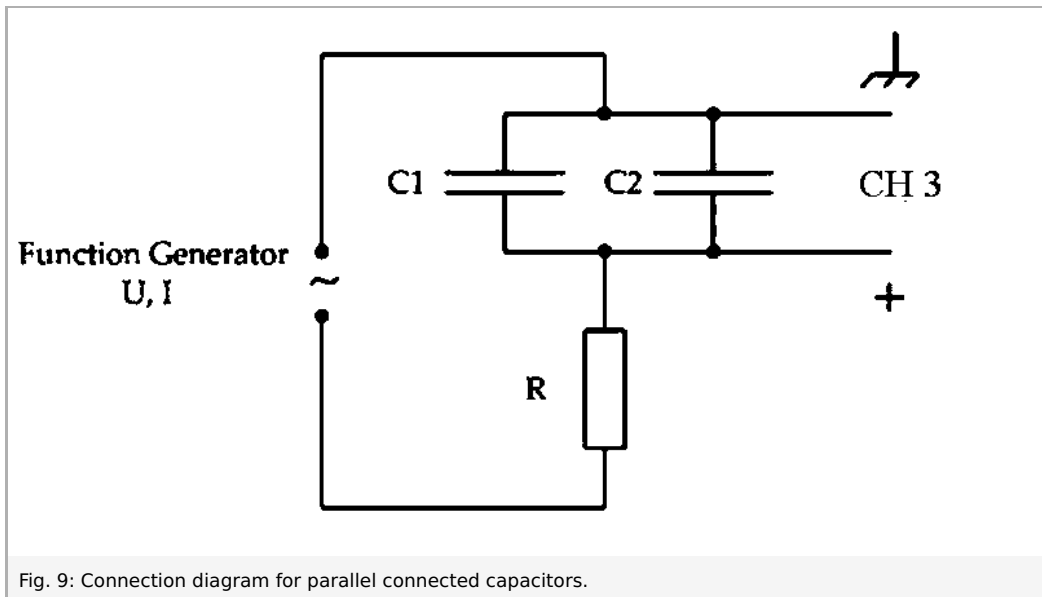

Fig. 7: Current plotted against frequency of the function generator.



Impedance of parallel and series connection

To investigate the influence of parallel and series connection of capacitors measure the impedance Z for configurations shown in fig. 9 and fig. 10. Use different combinations of capacitors and resistance. The total capacitance of two connected capacitors is given in the theory chapter.



Phase-shift measurement

To investigate the phaseshift $\Delta\phi$ between current and voltage, an oscilloscope is used. The voltage is measured with one channel of the oscilloscope according to fig. 11 over the capacitor and the resistor. To gain a current signal, the voltage drop over the resistor R is measured, which is proportional to the current. A picture of this set-up is shown in fig. 12. Out of both signals in the oscilloscope the time difference Δt between to maxima can be read off. An oscilloscope picture is given in fig. 13. Following the phase shift $\Delta\phi$ can be calculated with the used frequency f . Repeat this for different frequencies by changing the frequency at the Function Generator in the range of 20 Hz to 8 kHz. Plot the values of $\Delta\phi$ against the frequency. A graph like the one shown in fig. 14 should be obtained. This process is then repeated for different combinations of capacitors and resistors.

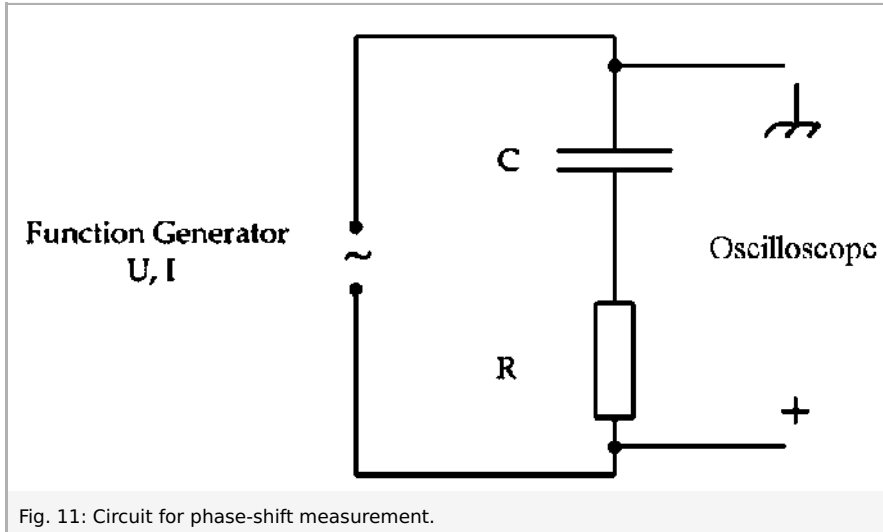

Fig. 11: Circuit for phase-shift measurement.

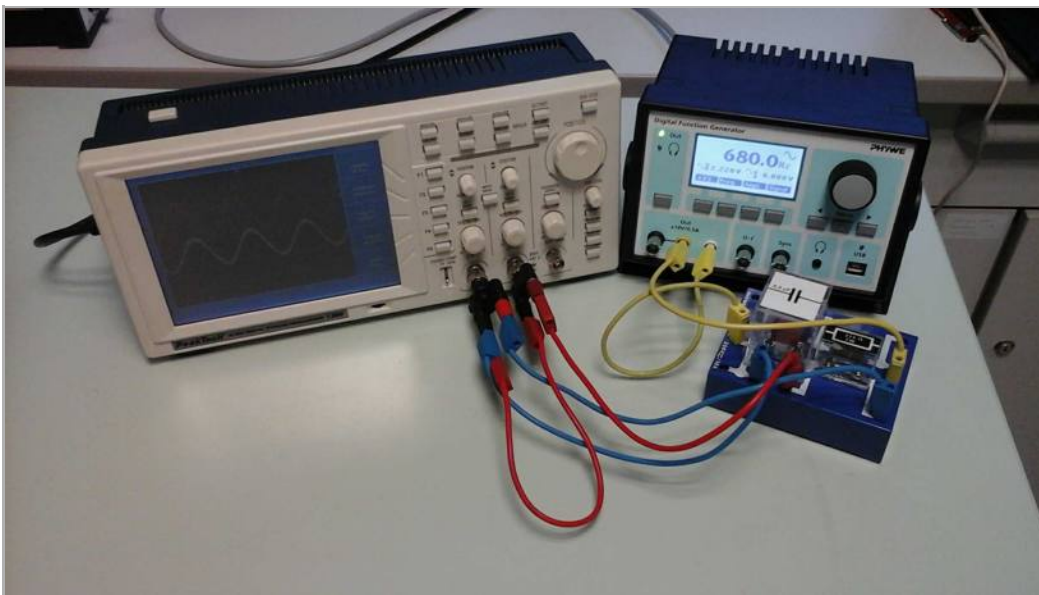

Fig. 12: Phase shift measurement set-up with oscilloscope.

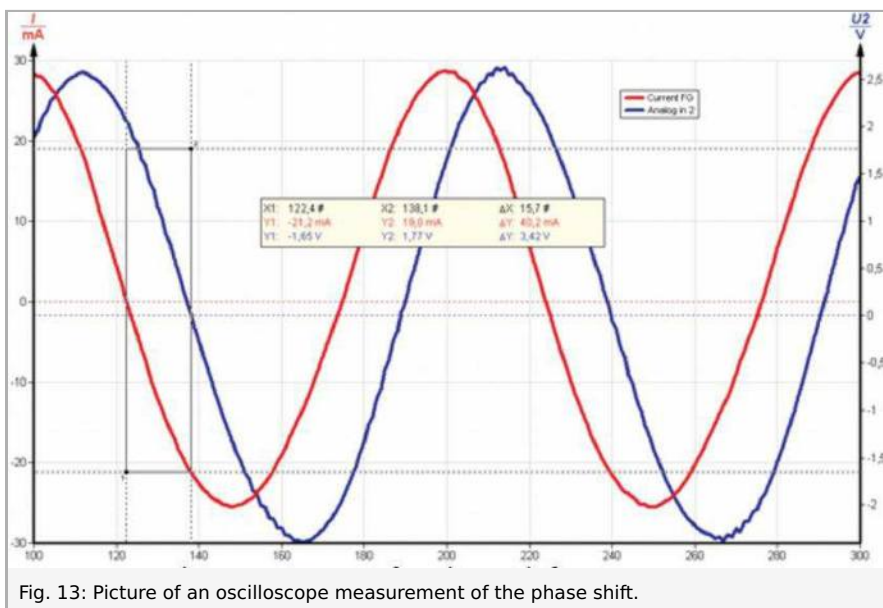

Fig. 13: Picture of an oscilloscope measurement of the phase shift.

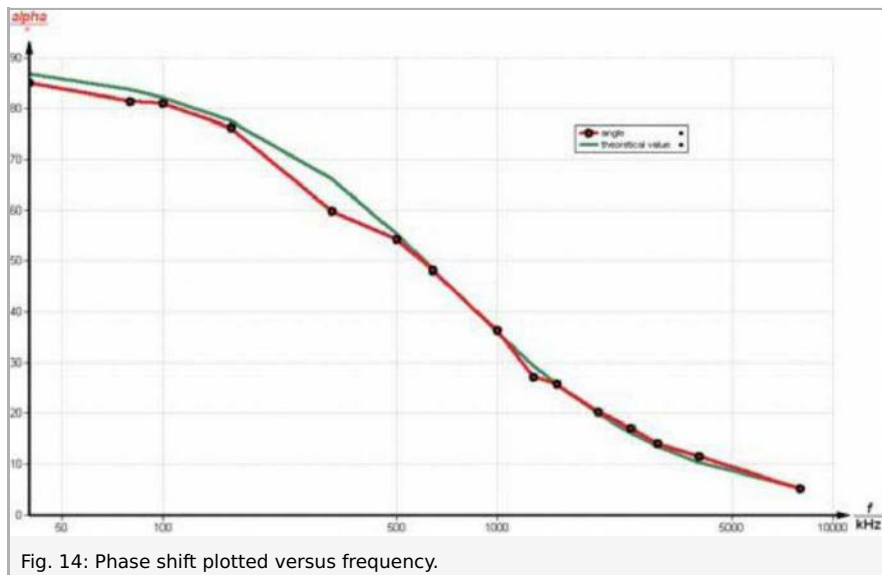

Fig. 14: Phase shift plotted versus frequency.

Theory and evaluation

Theory

The total capacitance C_{tot} for two capacitors C_1 and C_2 in a serial connection is

$$\frac{1}{C_{\text{tot}}} = \frac{1}{C_1} + \frac{1}{C_2}.$$

For a parallel connection both capacitors add to the total capacitance

$$C_{\text{tot}} = C_1 + C_2.$$

The voltage U_c on a capacitance C with charge Q

$$Q(t) = \int_{t_1}^{t_2} I(t) dt$$

can be calculated as

$$U_c(t) = \frac{Q(t)}{C}.$$

The voltage on the resistance R is with current $I(t) = dQ/dt$

$$U_R(t) = R \cdot I(t) = R \frac{dQ}{dt}.$$

For a series connection of a capacitor and resistance with an ac voltage source the voltage is

$$U(t) = U_c(t) + U_R(t) = \frac{Q(t)}{C} + R \frac{dQ}{dt} = U_0 \cos(\omega t).$$

Differentiating this equation yields

$$\frac{I}{C} + R \frac{dI}{dt} = -\omega U_0 \sin(\omega t).$$

This differential equation is solved by

$$I(t) = I_0 \cos(\omega t + \phi)$$

with

$$\tan(\phi) = \frac{1}{\omega RC} > 0.$$

This means the current is ahead of the voltage. The current amplitude I_0 can then be given as

$$I_0 = \frac{U_0}{\sqrt{R^2 + \left(\frac{1}{\omega C}\right)^2}}.$$

The impedance Z is defined as

$$Z = \frac{U_0}{I_0} = \sqrt{R^2 + \left(\frac{1}{\omega C}\right)^2}.$$

The capacitor contributes to the impedance ($R = 0$) with

$$Z_c = \frac{1}{\omega C} = \hat{R}_c.$$

If you plot the impedance vs. the inverse frequency, the slope m is then with $\omega = 2\pi f$

$$m = \frac{1}{2\pi C} \text{ or } C = \frac{1}{2\pi m}.$$

A table of the so determined capacities from the measurements in fig. 8 is shown in fig. 15.

imprinted value / μF	μF slope / Ohm/ms	measured value / μF
4.7	36 \pm 2	4.42 \pm 0.2
2.2	72 \pm 4	2.21 \pm 0.1
1	142 \pm 7	1.12 \pm 0.05

Fig. 15: Table of calculated capacities from impedance-period-time plots.