

Magnetic field of paired coils in a Helmholtz arrangement (Item No.: P2430301)

Curricular Relevance

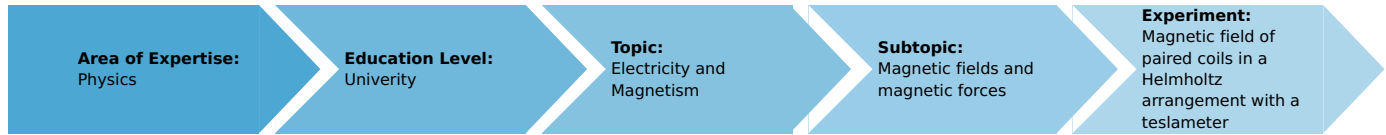

Difficulty



Easy

Preparation Time



20 Minutes

Execution Time



30 Minutes

Recommended Group Size



2 Students

Additional Requirements:

Experiment Variations:

Keywords:

Overview

Short description

Related topics

Maxwell's equations, wire loop, flat coils, Biot-Savart's law, Hall effect.

Principle

The spatial distribution of the field strength between a pair of coils in the Helmholtz arrangement is measured. The spacing at which a uniform magnetic field is produced is investigated and the superposition of the two individual fields to form the combined field of the pair of coils is demonstrated.



Fig. 1: Set-up of experiment P2430301

Equipment

Position No.	Material	Order No.	Quantity
1	PHYWE power supply, universal DC: 0...18 V, 0...5 A / AC: 2/4/6/8/10/12/15 V, 5 A	13504-93	1
2	Helmholtz coils, one pair	06960-00	1
3	Connecting cord, 32 A, 500 mm, blue	07361-04	2
4	Connecting cord, 32 A, 500 mm, red	07361-01	2
5	Digital multimeter 2005	07129-00	1
6	PHYWE Teslameter, digital	13610-93	1
7	Hall probe, axial	13610-01	1
8	Universal clamp	37715-00	1
9	Right angle clamp expert	02054-00	1
10	Support rod, stainless steel, l = 250 mm, d = 10 mm	02031-00	1
11	Barrel base expert	02004-55	1
12	Meter scale, l = 1000 mm	03001-00	2
13	G-clamp	02014-00	3

Tasks

1. Measure the magnetic flux density along the z-axis of the flat coils when the distance between them $a = R$ ($R =$ radius of the coils) and when it is greater and less than this.
2. Measure the spatial distribution of the magnetic flux density when the distance between coils $a = R$, using the rotational symmetry of the set-up:
 - a. measurement of the axial component B_z
 - b. measurement of radial component B_r
3. Measure the radial components B_r' and B_r'' of the two individual coils in the plane midway between them and to demonstrate the overlapping of the two fields at $B_r = 0$.

Set-up and procedure

Connect the coils in series and in the same direction, see Fig. 2; the current must not exceed 3.5 A (operate the power supply as a constant current source). Measure the flux density with the axial Hall probe (measures the component in the direction of the probe stem).

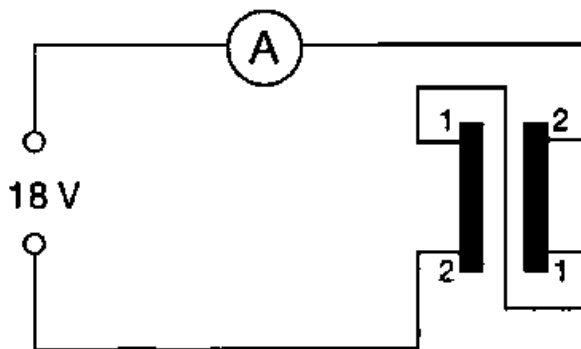

Fig. 2: Wiring diagram for Helmholtz coils.

The magnetic field of the coil arrangement is rotationally symmetrical about the axis of the coils, which is chosen as the z -axis of a system of cylindrical coordinates (z, r, Φ) . The origin is at the centre of the system. The magnetic flux density does not depend on the angle Φ , so only the components $B_z(z, r)$ and $B_r(z, r)$ are measured.

Clamp the Hall probe on to a support rod with barrel base, level with the axis of the coils. Secure two rules to the bench (parallel or perpendicular to one another, see Figs. 3-5). The spatial distribution of the magnetic field can be measured by pushing the barrel base along one of the rules or the coils along the other one.

Notes

Always push the barrel base bearing the Hall probe along the rule in the same direction.

1. Along the z -axis, for reasons of symmetry, the magnetic flux density has only the axial component B_z . Fig. 3 shows how to set up the coils, probe and rules. (The edge of the bench can be used instead of the lower rule if required.) Measure the relationship $B(z, r = 0)$ when the distance between the coils $a = R$ and, for example, for $a = R/2$ and $a = 2R$.

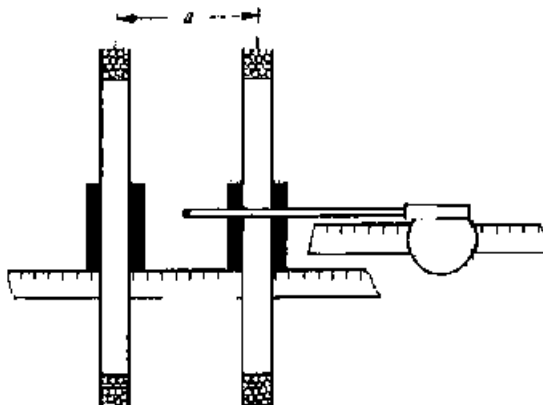

Fig. 3: Measuring $B(z, r = 0)$ at different distances a between the coils.

2. When distance $a = R$ the coils can be joined together with the spacers. a) Measure $B_z(z, r)$ as shown in Fig. 4. Set the r -coordinate by moving the probe and the z -coordinate by moving the coils. Check: the flux density must have its maximum value at point $(z = 0, r = 0)$. b) Turn the pair of coils through 90° (Fig. 5). Check the probe: in the plane $z = 0$, B_z must be 0.

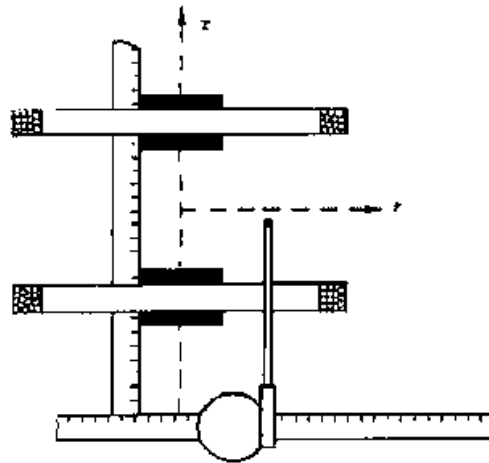

Fig. 4: Measuring $B_z(z, r)$.

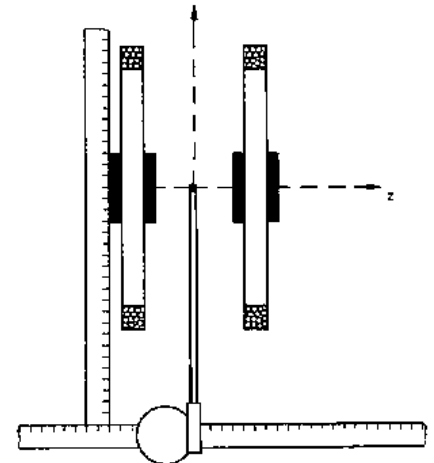

Fig. 5: Measuring $B_r(z, r)$.

3. Short-circuit first one coil, then the other. Measure the radial components of the individual fields at $z = 0$.

Theory and evaluation

From Maxwell's equation

$$\oint_K \vec{H} d\vec{s} = I + \int_F \int \vec{D} d\vec{f} dt \quad (1)$$

where K is a closed curve around area F , we obtain for direct currents ($\dot{D} = 0$), the magnetic flux law

$$\oint_K \vec{H} d\vec{s} = I \quad (2)$$

which is often written for practical purposes in the form of Biot-Savart's law:

$$d\vec{H} = \frac{I}{4\pi} \frac{d\vec{l} \times \vec{\rho}}{\rho^3} \quad (3)$$

where $\vec{\rho}$ is the vector from the conductor element $d\vec{l}$ to the measurement point and $d\vec{H}$ is perpendicular to both these vectors. The field strength along the axis of a circular conductor can be calculated using equation (3). (Fig. 6).

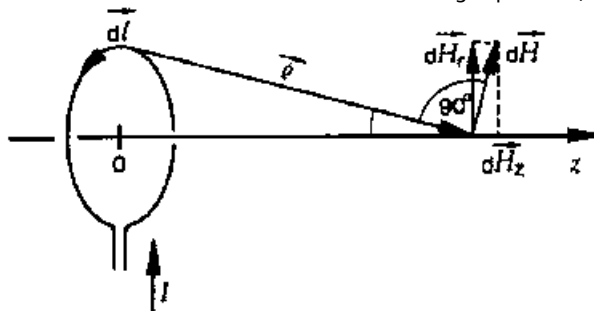

Fig. 6: Sketch to aid calculation of the field strength along the axis of a wire loop.

The vector $d\vec{l}$ is perpendicular to, and $\vec{\rho}$ and $d\vec{H}$ lie in, the plane of the sketch, so that

$$dH = \frac{I}{4\pi\rho^3} dl = \frac{I}{4\pi} \cdot \frac{dl}{R^2 + z^2} \quad (4)$$

$d\vec{H}$ can be resolved into a radial dH_r and an axial dH_z component.

The dH_z components have the same direction for all conductor elements $d\vec{l}$ and the quantities are added; the dH_r components cancel one another out, in pairs. Therefore,

$$H_r = 0 \quad (5)$$

and

$$H = H_z = \frac{I}{2} \cdot \frac{R^2}{(R^2 + z^2)^{3/2}} \quad (6)$$

along the axis of the wire loop, while the magnetic flux density

$$B(z) = \frac{\mu_0 \cdot I}{2R} \cdot \frac{1}{\left(1 + \left(\frac{z}{R}\right)^2\right)^{3/2}} \quad (7)$$

The magnetic field of a flat coil is obtained by multiplying (6) by the number of turns N . Therefore, the magnetic flux density along the axis of two identical coils at a distance α apart is

Student's Sheet

Printed: 12/09/2019 16:57:55 | P2430301

$$B(z, r = 0) = \frac{\mu_0 \cdot I \cdot N}{2R} \cdot \left(\frac{1}{(1+A_1^2)^{3/2}} + \frac{1}{(1+A_2^2)^{3/2}} \right) \quad (8)$$

where

$$A_1 = \frac{z+\alpha/2}{R}, \quad A_2 = \frac{z-\alpha/2}{R}$$

When $z = 0$, flux density has a maximum value when $\alpha < R$ and a minimum value when $\alpha > R$. The curves plotted from our measurements also show this (Fig. 7); when $\alpha = R$, the field is virtually uniform in the range

$$-\frac{R}{2} < z < +\frac{R}{2}$$

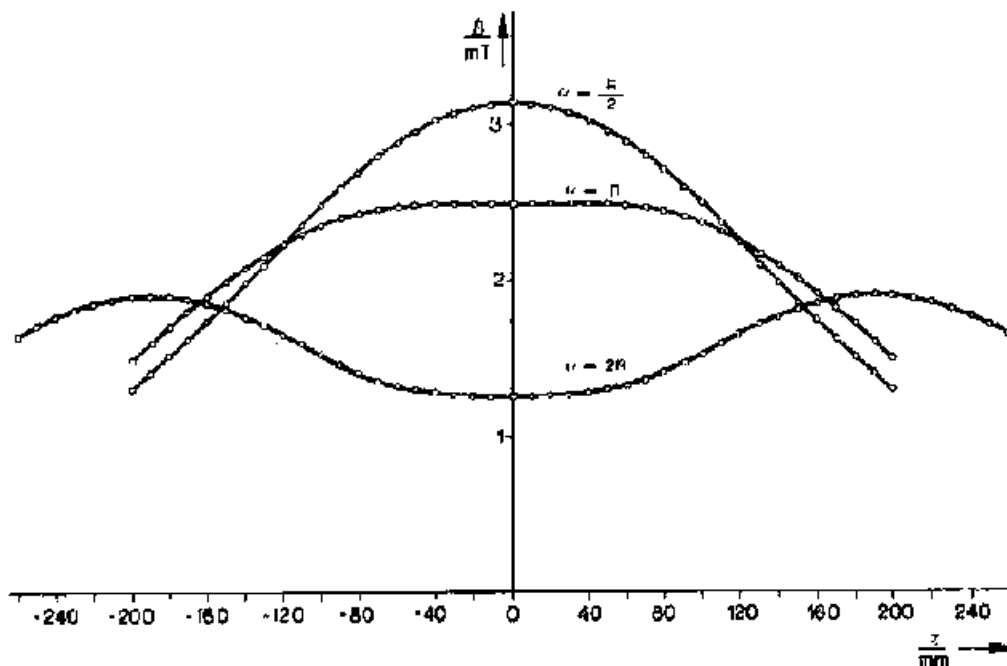

Fig. 7: $B (r = 0)$ as a function of z with the parameter α .

Magnetic flux density at the mid-point when $\alpha = R$:

$$B(0,0) = \frac{\mu_0 \cdot I}{2R} \cdot N \cdot \frac{2}{\left(\frac{5}{4}\right)^{3/2}} = 0.716 \mu_0 \cdot N \cdot \left(\frac{I}{R}\right)$$

when $N = 154$, $R = 0.20$ m and $I = 3.5$ A this gives:

$$B (0,0) = 2.42 \text{ mT.}$$

Our measurements gave $B (0,0) = 2.49$ mT.

Figs. 8 and 9 shows the curves $B_z (z)$ and $B_r (z)$ measured using r as the parameter; Fig. 10 shows the super-position of the fields of the two coils at $B_r = 0$ in the centre plane $z = 0$.

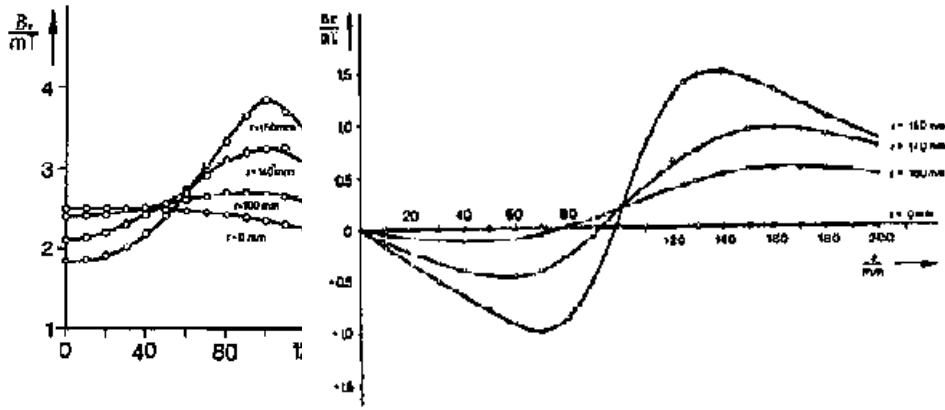

Fig. 8: $B_z(z)$, parameter r (positive quadrant only).

Fig. 9: $B_r(z)$, parameter r (positive quadrant only).

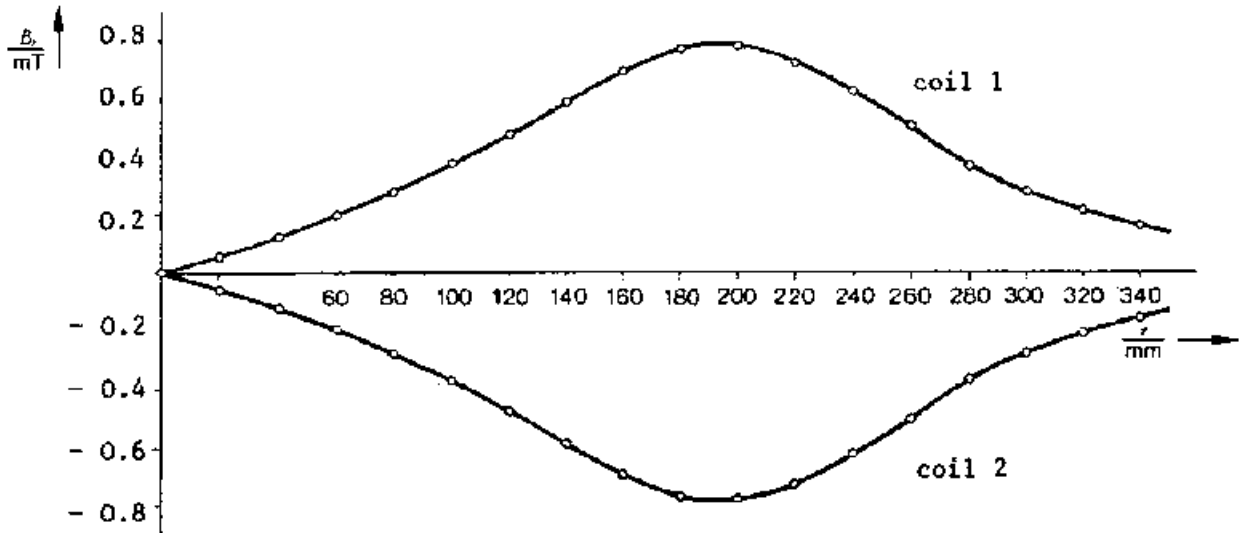

Fig. 10: Radial components $B_r'(r)$ and $B_r''(r)$ of the two coils when $z = 0$.