

Characteristic curves of semiconductors (Item No.: P2410964)

Curricular Relevance

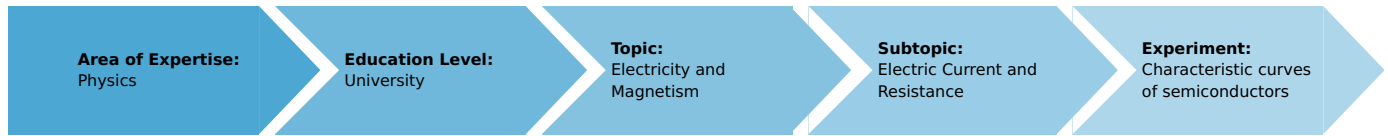

Difficulty



Very difficult

Preparation Time



20 Minutes

Execution Time



20 Minutes

Recommended Group Size



2 Students

Additional Requirements:

Experiment Variations:

Keywords:

Semiconductor, p-n junction, energy-band diagram, acceptors, donors, valence band, conduction band, diodes, Shockley equation, bipolar junction transistor

Overview

Short description

Principle

The current-voltage characteristics of different semiconducting diodes is measured.

For a npn-transistor the collector current in dependence on the collector-emitter voltage is measured for different values of base current strength.

The collector current is measured in dependence on base current. The base voltage is observed in dependence on base current.

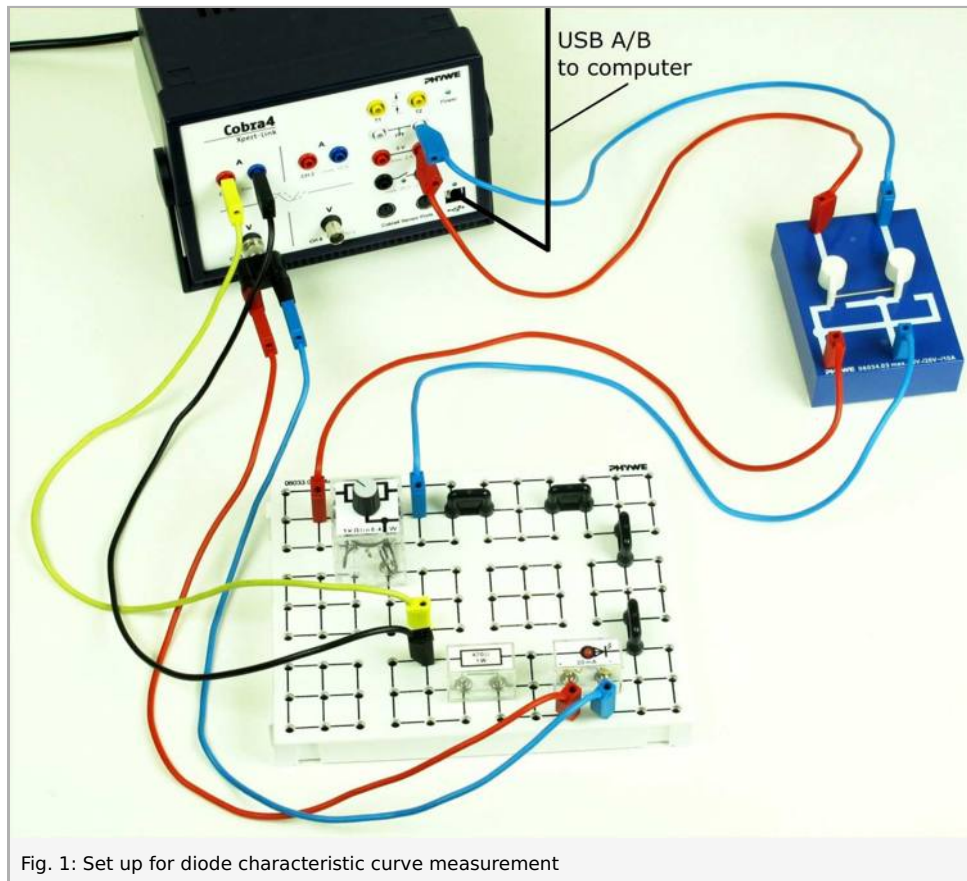

Fig. 1: Set up for diode characteristic curve measurement

Materials

Equipment

Position No.	Material	Order No.	Quantity
1	Cobra4 Xpert-Link	12625-99	1
2	Plug-in board, 4 mm sockets	06033-00	1
3	Short-circuit plug, black	06027-05	3
4	Commutator switch	06034-03	1
5	Potentiometer, 1 k Ω	39103-04	2
6	Resistor 470 Ω , 1W, G1	39104-15	1
7	Resistor 1 k Ω , 1W, G1	39104-19	1
8	Resistor 22 k Ω , 1W, G1	39104-34	1
9	Resistor 100 Ω , 1W, G1	39104-63	1
10	Diode, germanium	39106-01	1
11	Silicon diode 1N4007	39106-02	1
12	Silicon diode 1N4148	39106-03	1
13	Z-diode, ZF 4.7	39132-01	1
14	LED, red	39154-50	1
15	npn-Transistor in plug-in box, BC337	39127-20	1
16	Connecting cord, l = 500 mm, red	07361-01	4
17	Connecting cord, l = 500 mm, blue	07361-04	4
18	Connecting cord, l = 500 mm, yellow	07361-02	2
19	Connecting cord, l = 500 mm, black	07361-05	2
20	Adapter BNC plug - 4 mm sockets	07542-26	2
Additionally required			
	PC with USB-Interface, Windows XP or higher		

Tasks

1. Measure the current - voltage curve for 1N4007 and 1N4148 silicon diodes, a germanium diode, a Zener-diode and a red LED.
2. For a npn-tansistor measure the collector current - emitter-collector voltage curve for different fixed values of base current.
3. For a npn-transistor measure the collector current and base voltage in dependence on base current for fixed collector-emitter voltage.

Set-up and procedure: Diode characteristics

Set-up

Characteristic curves of diodes

Connect the 5 V DC output of the Xpert-Link to the cross-over switch. The cross-over switch feeds a 1 k Ω potentiometer that then provides on its slider connector a range of -5...5 V if unloaded. Next a 470 Ω resistor limits the maximum current to 10.6 mA maximum which can't destroy any of the diodes. If the diode can pass 10.6 mA at a given voltage, the voltage range on the diode will end there because the rest of the voltage will drop across the 470 Ω resistor and the potentiometer resistance.

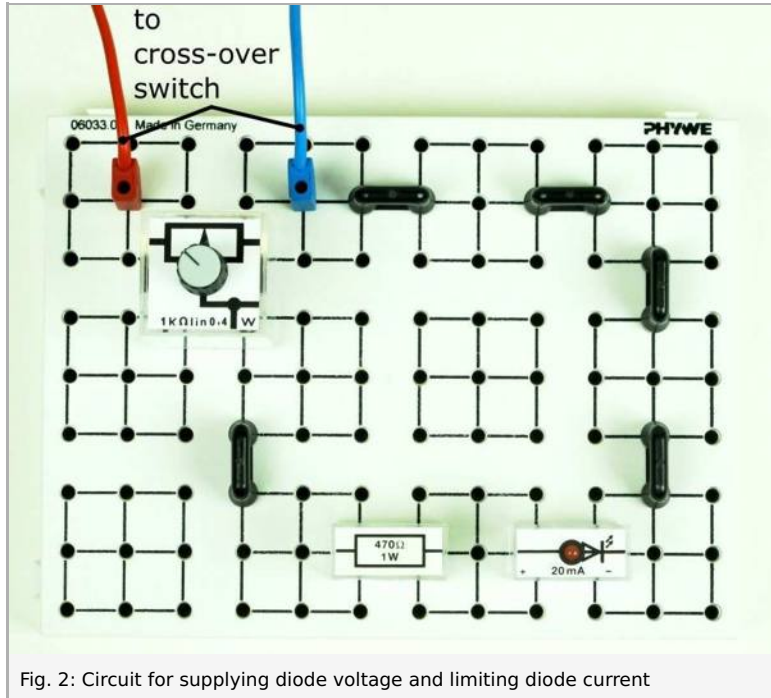

Fig. 2: Circuit for supplying diode voltage and limiting diode current

Connect in series with the slider the current input CH1 of the Xpert-Link. The voltage input CH3 of the Xpert-Link is put in parallel with the diode.

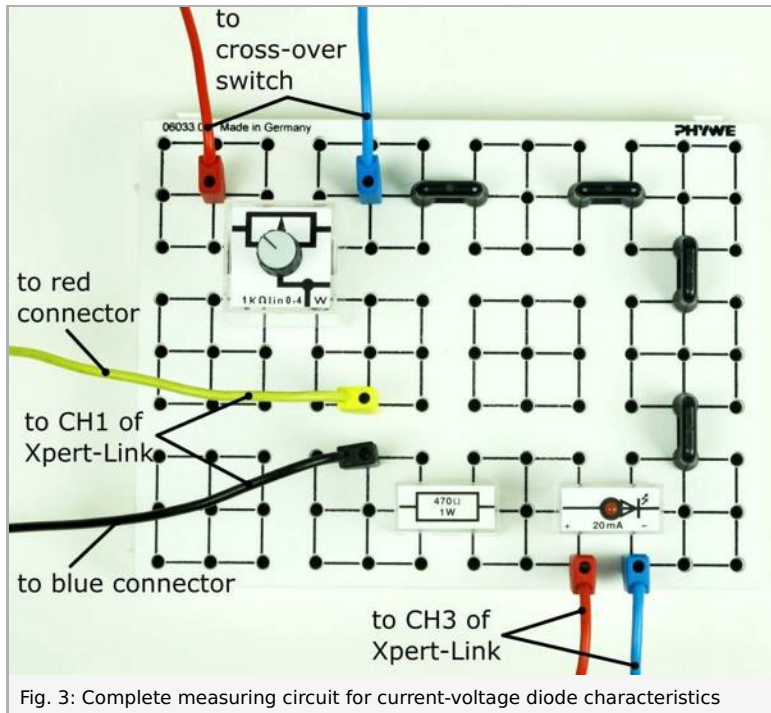

Fig. 3: Complete measuring circuit for current-voltage diode characteristics

Configure measureLAB

Run measureLAB. In the quick start menu, that appears at program start up or by clicking the "Home" icon, select PHYWE experiments > Physics > University > Electromagnetism > DC circuits, select "Characteristic curves of semiconductors: Diode

characteristics"

If not using the presets, then set e.g. the following: Click on the upper left corner of the window the Xpert-Link Icon, click the "Lock" icon if it is open, wait for the red line to turn green, select "Current CH1 I1", select "Digital display", drag "Voltage CH3 U1" into that display. Select "Current CH1 I1", select "Diagram", drag "Voltage CH3 U1" into that diagram, in the diagram click the "diagram" icon, in the drop-down menu "X:" select "Voltage CH3" as x-axis. Now the diagram is ready to display characteristic curves current over voltage.

Now open the settings menu using the gearwheel icon. In "Sensors/Channels" select for CH1: 10 mA, averaging over 200 values; CH3: 10 V, averaging over 200 values. For each Channel select an appropriate number of digits in "Decimal places" and confirm all settings with the "Apply" button in order to transfer settings to the Xpert-Link.

In "Measurements" select 2.5 ms corresponding to 400 Hz.

Procedure

Procedure: characteristic curves of diodes

Set the control on the potentiometer such that the voltage on the circuit is maximum, that is the potentiometer slider is all the way to the red terminal. Start data recording with the "Start" button in the lower left corner of the measureLAB window. Slowly turn the control so the slider moves towards the blue terminal to the end, then switch the cross-over switch, slowly turn the control all the way back and stop the measurement.

Exchange the diode with the next type and repeat that procedure with all five types of diodes.

You should receive a set of characteristic curves that should look like this:

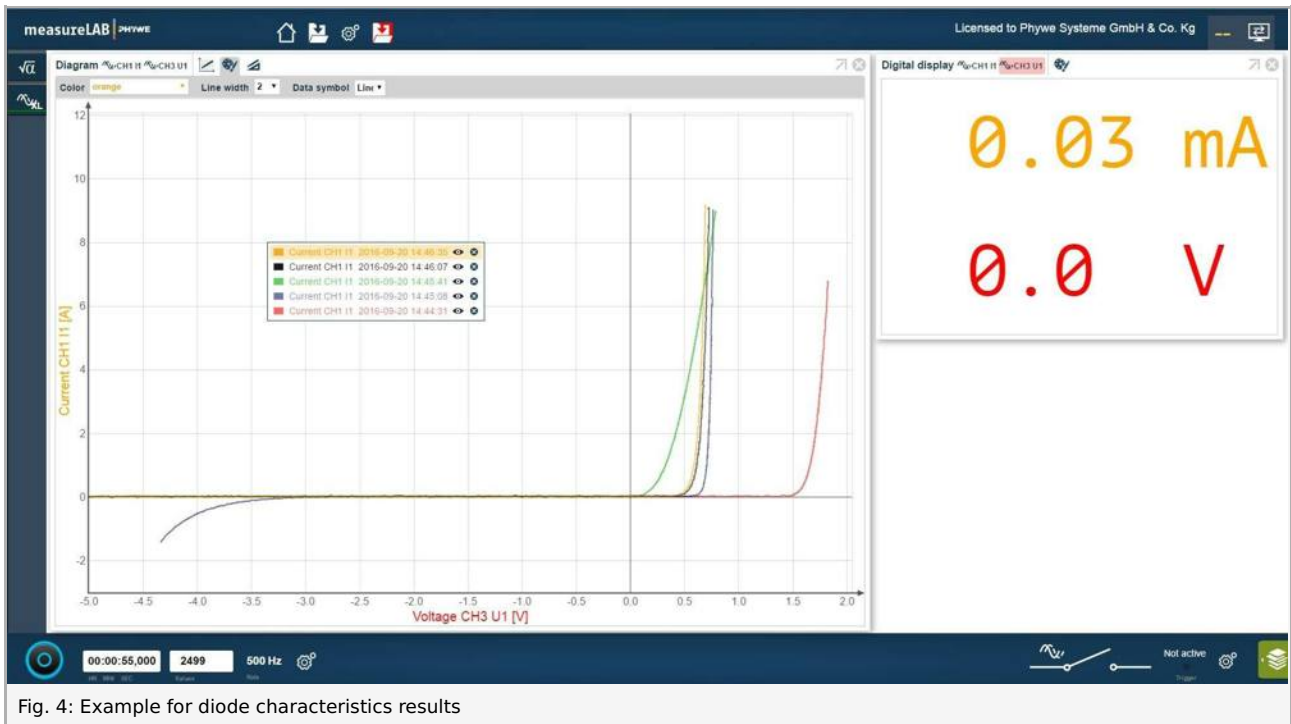

Fig. 4: Example for diode characteristics results

Fig. 4 shows: Red: Z-diode 4.7, green: Ge-diode AA118, black: Si small signal diode 1N4148, orange: Si rectifier diode 1N4007.

Shockley ideal diode equation

Remeasure the positive branch of the characteristic curves for a LED, Si- and GE-diode. In the diagram window click the diagram icon and set "Y:" to "Log" so you have a logarithmic plot of the current over voltage. If the current would rise exponentially with the voltage, this diagram then would show a linear rise. The result might look like Fig. 5.



Fig. 5: Logarithmic plot of diode current over diode voltage

From left to right Fig. 5 shows the logarithmic curves of the Ge-diode, of Si-diodes 1N4007 and 1N4148, and the red LED. The linear section (where current rises exponentially) for Ge is small, for the Si diodes exceeds the measuring range, and for the LED is relatively small again. For small diode voltages here current signal noise dominates. With sensitive measuring gear the reverse saturation current could be measured. For large currents the ohmic resistance starts to play a role. In the intermediate range the diffusion current dominates and the Shockley diode equation predicting exponential behaviour applies. With some diodes, before ohmic resistance sets in, there can be a deviation from Shockley law when the current exceeds the diffusion current assumed in this law. The ohmic resistance of the Ge diode is relatively large, followed by the LED.

Results and evaluation: Diode characteristics

Theoretical background

p-n junction properties

A p-doped semiconductor contains impurities called acceptors that can catch electrons from the valence band. E.g. in a typical semiconductor made of atoms with four valence electrons like silicon this might be an element of group III in the periodic table, e.g. boron. The reacting electron level is near the band edge, so that at room temperature a considerable part of these levels is occupied thus forming holes in the valence band. The holes in the valence band act as mobile charge carriers while the acceptor ions stay immobile in the crystal lattice.

In a similar way an n-doped semiconductor contains impurities called donors capable of delivering electrons by thermal excitation to the conduction band as mobile carriers. For a four-valent semiconductor of group IV these would be elements of group V such as phosphorous.

In thermal equilibrium the Fermi level usually lies in between the band edge and the ionized impurity levels.

When an n-doped and a p-doped semiconductor are brought in contact, a p-n junction forms:

In the contact area some electrons from the donors of the n-doped semiconductor recombine with the acceptors of the p-doped semiconductor without creating mobile charge carriers but creating a space charge, a barrier layer. The electric field of this space charge equalizes the Fermi levels of both parts and affects the mobility of charge carriers in the valence- or conduction band. In both of them the space charge is such that it repels the mobile carriers. So the contact area is depleted of carriers - a depletion zone is formed (Fig. 6). A p-n junction almost completely blocks electric conduction. Since the activation energies of these reactions are within thermal energy range at room temperature, there is a diffusion current inside the depletion layer - impurities keep releasing and catching charges from their surrounding impurity levels or energy bands. A smaller fraction on the surface of the space charge region can also release their charges to the outside of the space charge region producing a reverse current, if there is reverse bias on the junction, or a forward current for small forward bias.

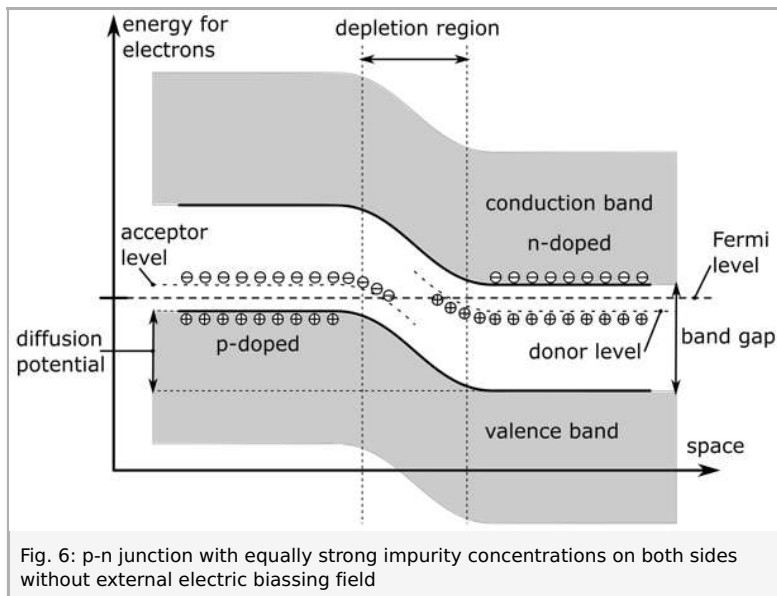

If a voltage is applied to such a device the polarity makes a difference: If the negative terminal is connected to the p-doped part, this is called reverse biasing of the diode. The energy level of the electrons is raised in the p-doped and lowered in the n-doped section. The space charge can increase now because it is for more impurities energetically favorable to recombine with the other impurity type until the field inside the bulk p- or n-doped section vanishes again - remember it is electrically conducting. So the depletion layer gets thicker and the space charge electrical field stronger. The p-n junction still blocks electrical conduction as the mobile carriers are repelled from the space charge region.

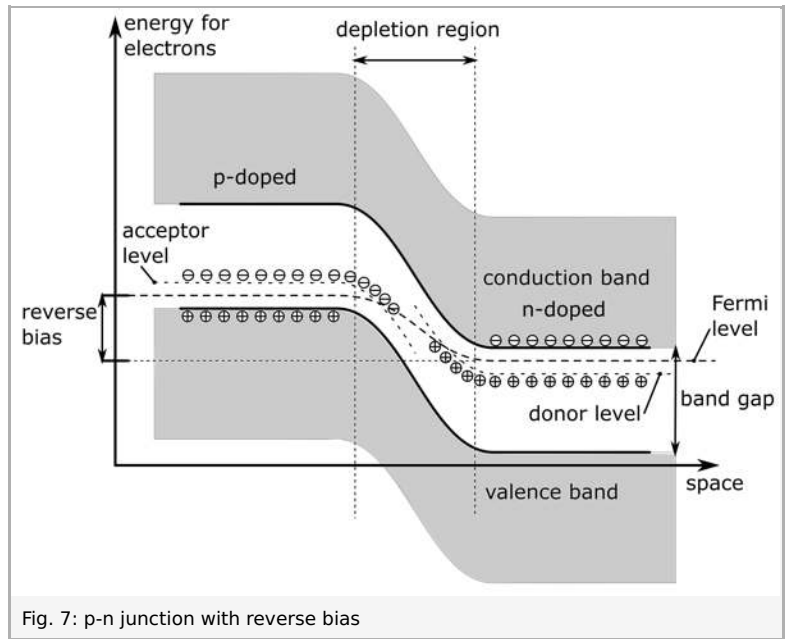

Forward biasing the diode means to put the positive terminal to the p-doped part. Then, at low voltages, still no current flows since the carriers would have to get over the diffusion potential to cross the depletion layer. Only if the voltage equals the diffusion potential, the band edges “get straight”, the space charge and the depletion layer get dissolved and forward current can flow. Holes and electrons can enter the oppositely doped region and recombine there.

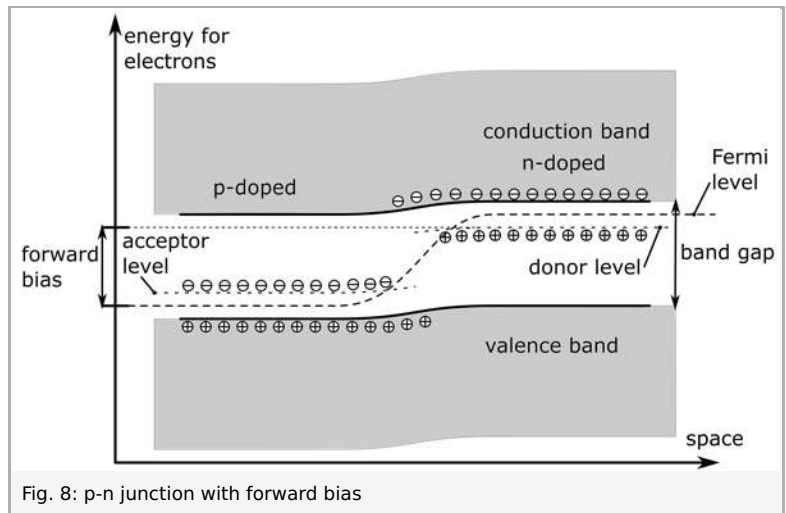

Shockley ideal diode equation

$$I = I_S \left(e^{\frac{V_D}{n k_B T / e}} - 1 \right)$$

with diode current I , reverse saturation current I_S , quality factor n , Boltzmann constant k_B , temperature T and electron charge e .

If ohmic resistance is negligible and the current large compared to reverse current, then this equation predicts an exponential increase of the current with the voltage. So an ideal diode can be used in combination with a linear operational amplifier for a circuit that outputs the logarithm of an input signal or the inverse of that. Adding voltages can be done with resistors, so two of those circuits can perform a multiplication of input signals. Thus diodes can prove helpful for analogue signal manipulation circuits.

Technical significance

Semiconductor diodes are made of p-n junctions. One main purpose is their operation as as electronic valves, allowing conduction in mainly one direction, e.g. as rectifiers. The different properties of the semiconductors cause the different properties of the diodes, that is impurity concentration on both sides, band gap, and if the semiconductor is a direct or indirect one. In direct semiconductors the lower edge of valence band, that is where the minimum energy states are in momentum (k -)space, is at the same momentum where the valence band energy has its maximum. In indirect semiconductors conduction-band energy minimum is not at the same momentum (k -)space position where valence band energy maximum is. So a phonon could serve to supply the needed momentum difference for band-band transitions, changing probabilities for photon reactions, as photon and phonon would have to react simultaneously.

Figs. 6 to 8 do not show the momentum space structure that the bands have - momentum space is inverted usual space for the electrons inside a periodic potential of a crystal.

If the dopant concentration is larger, then the thickness of the depletion layer gets smaller, the electrical fields inside the junction stronger. This can have two consequences: For large dopant concentration the thickness can be small enough that electrons can tunnel through the depletion layer leading to a reverse tunnel current called Zener current. If the doping is strong enough that this can already happen at zero applied voltage, the device is called a tunnel diode. Tunnel diodes have larger reverse than forward conductivity and their curvature of the characteristic curve can be larger than with usual diodes, so they can be HF small signal rectifiers. If the tunnel current is significant for small reverse bias, the device is a Zener diode. As second consequence with lesser dopant concentration there will be a threshold for the electrical field where electrons inside the barrier layer will be accelerated sufficiently that they can by collision excite more electrons into conduction band. This would be an avalanche breakdown. If the dopant concentration is still high enough that the avalanches don't get destructively large, then the device will also work the same way as a Zener diode. Because most times avalanche and Zener currents are both present, devices are called Z-diodes.

Z-diodes can be used as overvoltage protectors or as voltage regulators as they can branch away current if the voltage is exceeding the rated Z-voltage. For this purpose they are connected in reverse mode.

While tunnel current will increase with rising temperature as the number of participating carriers increases - the temperature coefficient of the Zener voltage is negative but not very dependent on Zener voltage value-, avalanche current will decrease with rising temperature as more carriers will get scattered inside the barrier layer before they can create avalanches - the Z-voltage temperature coefficient is positive, the more, the thicker the barrier layer is that is the higher the Z-voltage is rated. If temperature coefficients of avalanche and Zener current cancel, the devices can be voltage reference diodes.

In case of direct semiconductors - not silicon - the charge carriers of forward current - not at recombination can emit their energy difference not only thermally but also as photon - useful for LEDs.

The other way around photons can be absorbed inside the semiconductor and excite electrons into conduction band. With presence of a barrier layer the semiconductor can thus work as photodetector or photovoltaic element.

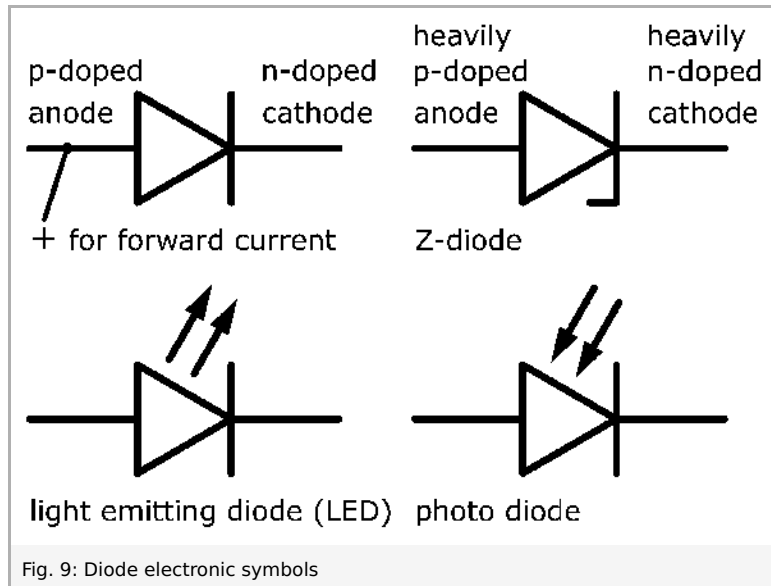

Results

The measured characteristic curves show that for the measured diodes the current is only on for one polarity of the voltage except for the Z-diode, which can also conduct in reverse direction - but for a larger threshold than in forward direction.

Also it shows that forward voltage depends on the semiconductor material.

Germanium forward voltage is lower than silicon forward voltage. The red LED (GaAsP) has the highest forward voltage.

The logarithmic plot proves that there is a range where the diodes behave according to Shockley ideal diode equation.

The Ge and GaAsP diodes show larger deviations from Shockley ideal diode behaviour, Zener current and avalanche current are not taken into account for the ideal diode equation.

Set-up and procedure: npn bipolar junction transistor characteristics

Set-up

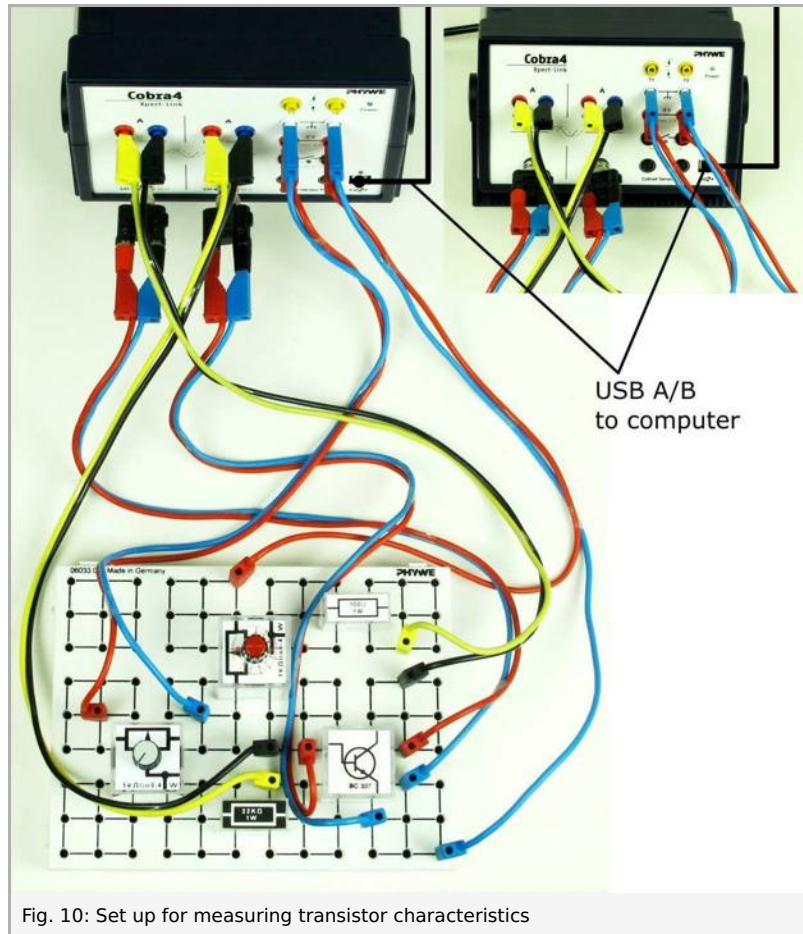

Fig. 10: Set up for measuring transistor characteristics

Both base and collector are connected to a settable voltage of 0...5 V, the two settable voltages are provided by the sliders of 1 kΩ potentiometers connected to the 5 V supply of the Xpert-Link. The base current is limited by a 22 kΩ resistor and the collector current is limited by a 100 Ω resistor. The emitter of the transistor is connected to ground, same potential as the negative 5 V output.

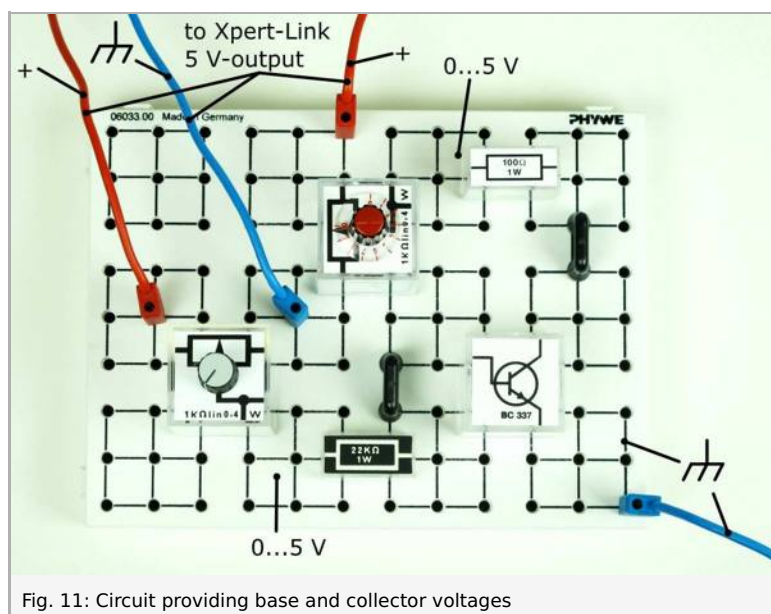

Fig. 11: Circuit providing base and collector voltages

Parallel to collector and emitter of the transistor the Xpert-Link voltage input CH3 is connected. Parallel to base and emitter of the transistor the Xpert-Link voltage input CH4 is connected.

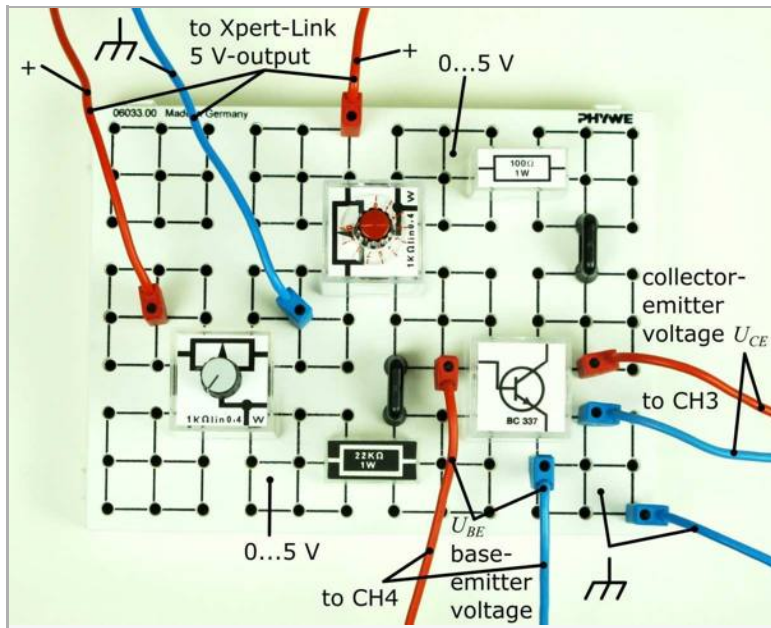

Fig. 12: Insert voltage pick-ups

Into the branch connecting the collector the Xpert-Link current input CH1 is put into series. Into the branch connecting the base the Xpert-Link current input CH2 is put into series.

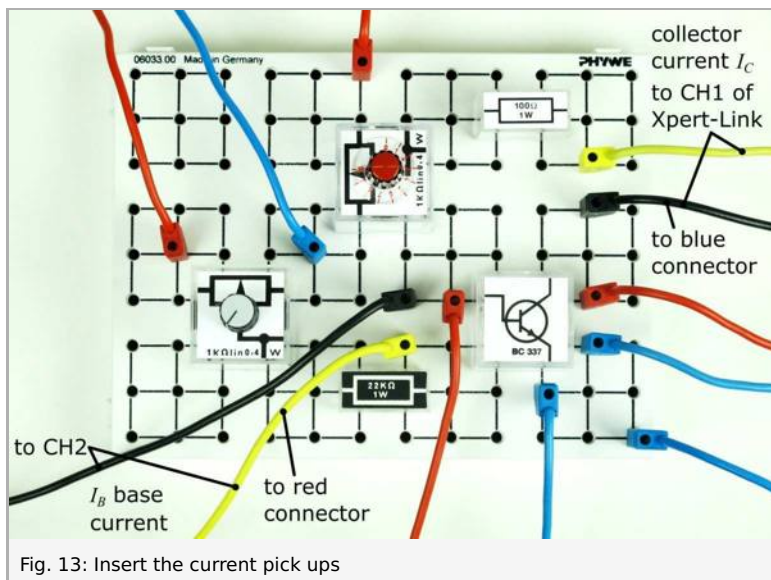

Fig. 13: Insert the current pick ups

Configure measureLAB

Run measureLAB. In the quick start menu, that appears at program start up or by clicking the "Home" icon, select PHYWE experiments > Physics > University > Electromagnetism > DC circuits, select "Characteristic curves of semiconductors: Transistor characteristics"

If not using the presets, then set e.g. the following: Click on the upper left corner of the window the Xpert-Link Icon, click the "Lock" icon if it is open, wait for the red line to turn green, select "Current CH1 I1" (collector current I_C), select "Digital display", drag "Current CH2 I2" (base current I_B), "Voltage CH3 U1" (collector-emitter voltage U_{CE}), and "Voltage CH4 U2" (base-emitter voltage U_{BE}), into that display. Select "Current CH1 I1", select "Diagram", drag "Voltage CH3 U1" into that diagram, in the diagram click the "diagram" icon, in the drop-down menu "X:" select "Voltage CH3" as x-axis. Now the diagram is ready to display characteristic curves collector current I_C over collector-emitter voltage U_{CE} .

Now open the settings menu using the gearwheel icon. In "Sensors/Channels" select for CH1: 100 mA, averaging over 200 values, 1 decimal place; CH2: 1 mA, averaging over 200 values, 3 decimal places; CH3: 10 V, averaging over 200 values, 2 decimal places; CH4: 1 V, averaging over 200 values, 3 decimal places. Confirm all settings with the "Apply" button in order to transfer settings to the Xpert-Link before changing to the chart for the next channel.

In "Measurements" select 2.5 ms corresponding to 400 Hz.

Procedure

Procedure: Collector current over collector voltage bipolar transistor characteristics

Set the slider of the potentiometer providing the base voltage such that the base voltage is zero. Since the transistor is blocking

now, the collector voltage should react to changes of the potentiometer providing the collector voltage. Now set the collector feeding potentiometer such that the collector voltage is zero. If you change the base voltage potentiometer, the base current should react, the base voltage should saturate slightly above 0.6 V and the base current should be settable from zero to above 200 μA with base voltage only slightly changing.

Set the base current to 20 μA , start data recording with the measureLAB button on the lower left of the window. Slowly turn the collector feeding potentiometer fully up, then stop the measurement. Turn the collector feeding potentiometer back to zero voltage.

Increase the base current roughly about 5 μA and repeat this procedure.

Note that for larger base currents the maximum collector voltage reduces as with increasing current the voltage drops across the limiting resistor.

Note that also for higher currents there may be artefacts and hysteresis in the characteristic curve, because the transistor is heating up and thus lowering its resistance, if loaded with current at some voltage.

The collector current in dependence on collector voltage for different base current curves should look like Fig. 14.

At the end of the curves you can see small hooks that appeared while the transistor was heating up in the time until the measurement was stopped.

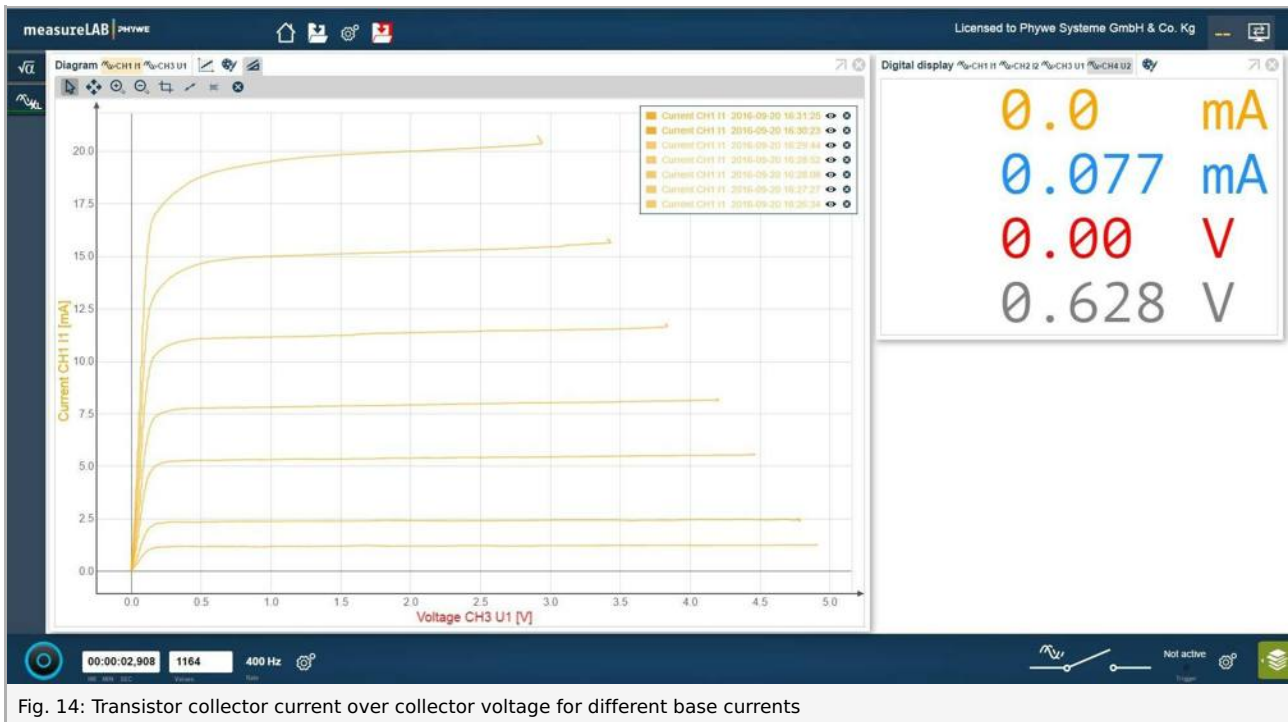

Fig. 14: Transistor collector current over collector voltage for different base currents

In Fig. 14 the base current is from bottom to top: 23 μA , 26 μA , 35 μA , 43 μA , 53 μA and 63 μA .

Procedure: Collector current over base current bipolar transistor characteristics

Reconfigure measureLAB:

Drag "Current CH2 I2" (base current I_B) and "Voltage CH4 U2" (base-emitter voltage U_{BE}) into the diagram. In the diagram click the "diagram" icon, in the drop-down menu "X:" select "Current CH2 I2" (base current I_B) as x-axis. Remove "Voltage CH3 U1" (collector-emitter voltage U_{CE}) from the diagram, for this right-click the channel icon in the top row of the diagram window. Now the diagram is ready to display characteristic curves collector current I_C over collector-emitter U_{CE} voltage.

Now open the settings menu using the gearwheel icon. In "Sensors/Channels" select for all channels averaging over 800 values - the base current measurement is on its most sensitive range and noise could blur the signal which is chosen as x-axis. In "Measurements" select 1.25 ms corresponding to 800 Hz.

Now the diagram will display "Current CH1 I1" (collector current I_C) and "Voltage CH4 U2" (base-emitter voltage U_{BE}) over "Current CH2 I2" (base current I_B).

Procedure

Set the base current to zero so the transistor blocks (is "off") and set the collector voltage to about 3 V - so heating of the transistor should be small.

Start the measurement and very slowly turn the knob on the base feeding potentiometer.

When the collector current no longer increases - the collector-emitter voltage U_{CE} has completely broken down - then stop the measurement.

An image as Fig. 15 should result.

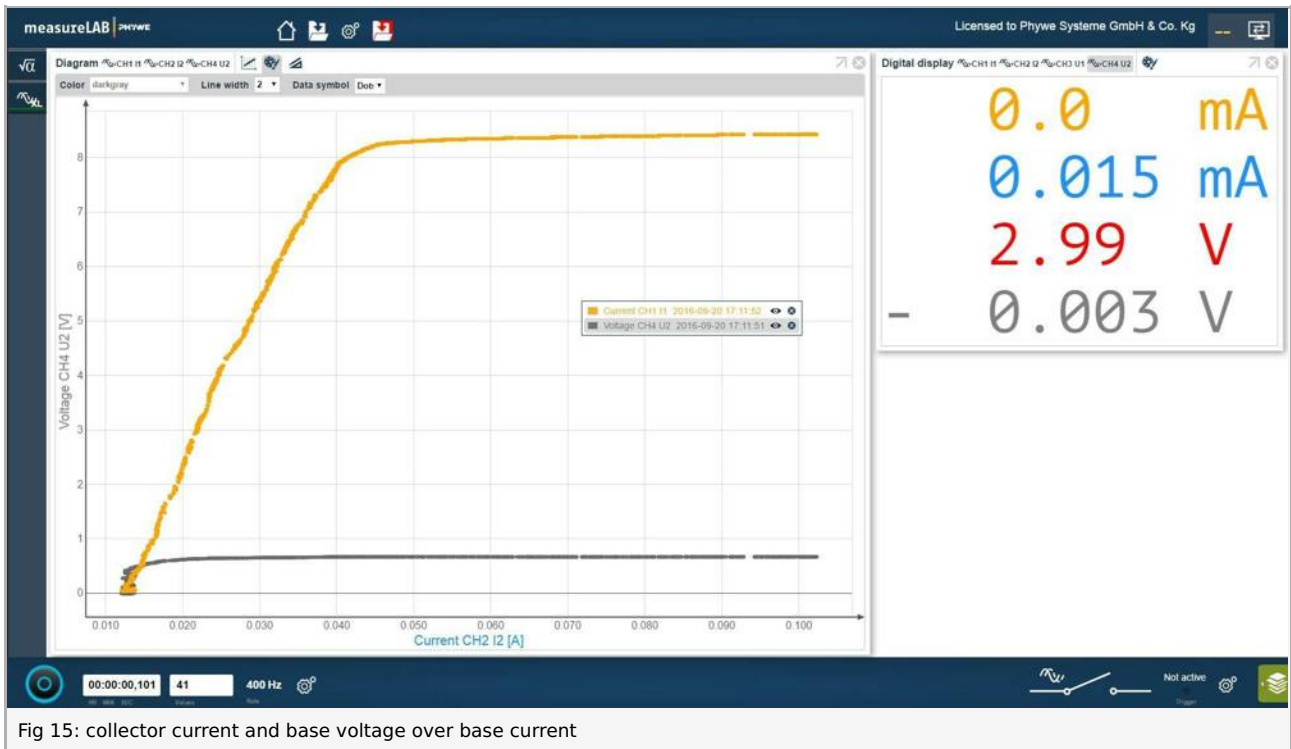

Fig 15: collector current and base voltage over base current

Results and evaluation: npn bipolar junction transistor characteristics

Theoretical background

A transistor that is formed by two opposite p-n junctions, a pnp or a npn device, is called a bipolar junction transistor. Such a device will block current in either direction – one of the barrier layers will always be reverse biased -, unless carriers are injected in the middle region destroying one of the depletion zones or barrier layers which makes the device permeable to current. So the middle region is electrically contacted and this contact is called base. To make such a device a good amplifier, the other regions are asymmetrically doped and also of asymmetrical geometry and thus making one contact the emitter and the other the collector. E.g. with a npn transistor like the BC337 there is only current gain, if the emitter is connected to the negative terminal, the collector to the positive terminal and the base is made a little positive injecting holes into the barrier layer between base and collector and thus weakening it.

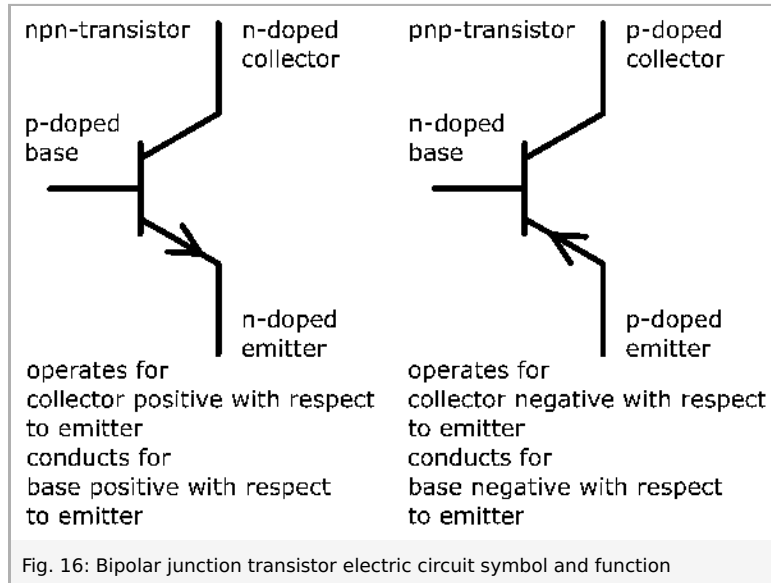
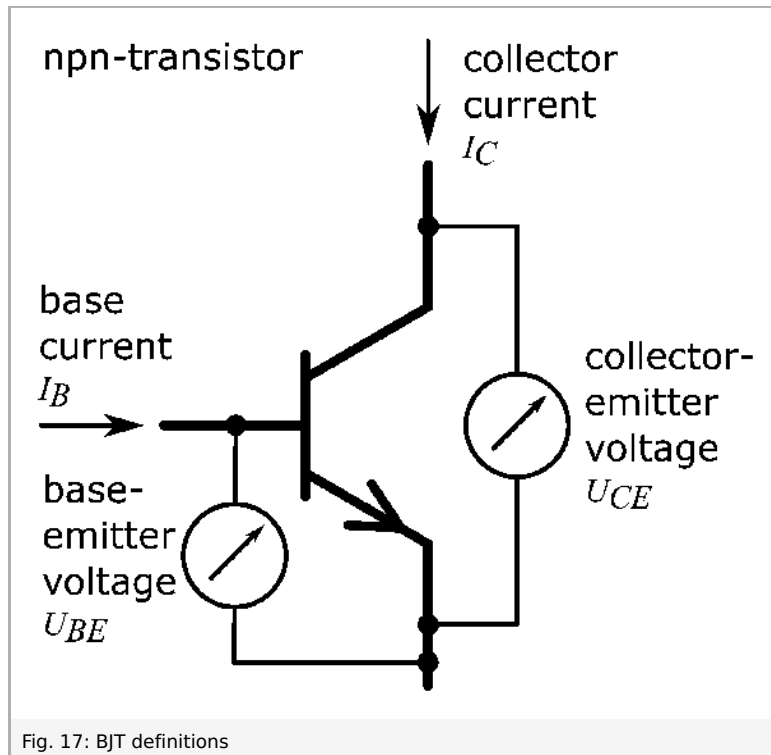

Fig. 17 shows the designators usually chosen in data sheets referring to bipolar junction transistor (BJT). The voltage designators U_{XY} denominate the difference: potential at X minus potential at Y . So in datasheets for pnp transistors the entries often read U_{EC} and then contain positive values.



Results

Collector current over collector-emitter voltage characteristic

The recorded diagrams show the following:

For a given base current, the bipolar junction transistor will let pass a collector current I_C that is almost independent on collector-emitter voltage U_{CE} .

There seem to be necessary prerequisites:

First is that U_{CE} has to be large enough to overcome the junction diode voltage threshold: The current starts at zero and has a sharp rise, then showing a plateau for voltages above typical silicon diode threshold voltages.

Next is that I_C be small enough that the transistor ohmic resistance does not play a significant role: For larger I_C there is a slope in the characteristic line because of this ohmic resistance that is in series with the transistor action.

Third heating of the transistor can play a role as the transistor properties depend on temperature.

Collector current over bias current characteristic

The collector current I_C rises in linear manner with base current I_B . The base current I_B shows with the base-emitter voltage U_{BE} a typical silicon diode characteristic curve. So once base current is flowing, the base voltage does not vary much. In total the transistor does not act as a voltage amplifier, but as a current amplifier. The collector current I_C stops its rise once all current provided by the source is drained, the collector voltage U_{CE} then can drop way below diode threshold voltage.

The current amplification I_C / I_B is 400, 16 mA per 40 μ A.

The collector current was intentionally limited so that there is no risk of thermally destroying the low power transistor.