

Nd-YAG laser (Item No.: P2260900)

Curricular Relevance



Difficulty



Difficult

Preparation Time



20 Minutes

Execution Time



10 Minutes

Recommended Group Size



1 Student

Additional Requirements:

Experiment Variations:

Keywords:

Optical pumping, Spontaneous emission, Induced emission, Inversion, Relaxation, Optical resonator, Resonator modes, Polarization, Frequency doubling

Principle and equipment

Principle

The rate equation model for an optically pumped four-level laser system is determined. As lasing medium, a Nd-YAG (Neodymium-Yttrium Aluminium Garnet) rod has been selected which is pumped by means of a semiconductor diode laser.

The IR-power output of the Nd-YAG laser is measured as a function of the optical power input and the slope efficiency as well as the threshold power are determined. Finally, a KTP-crystal is inserted into the laser cavity and frequency doubling is demonstrated. The quadratic relationship between the power of the fundamental wave and the beam power for the second harmonic is then evident.



Fig. 1: Experimental set-up of the Nd-YAG laser system

Student's Sheet

Printed: 04.12.2017 17:40:02 | P2260900

Tasks

1. Set up the Nd-YAG laser and optimize its power output – see experiment 2.6.08 “Optical pumping”.
2. The IR-power output of the Nd-YAG laser is to be measured as a function of the pump power. The slope efficiency and the threshold power are to be determined.
3. Verify the quadratic relationship between the power of the fundamental wave, with $\lambda = 1064$ nm, and the beam power of the second harmonic with $\lambda = 532$ nm.

Equipment

Position No.	Material	Order No.	Quantity
1	Basic set optical pumping	08590-93	1
2	Sensor for measurement of beam power	08595-00	1
3	Nd-YAG laser cavity mirror/holder	08591-01	1
4	Laser cav.mirror frequ. doubling	08591-02	1
5	Frequ. doubling crystal in holder	08593-00	1
6	Filter plate, short pass type	08594-00	1
7	Digital multimeter 2005	07129-00	1
8	30 MHz digital storage oscilloscope with colour display, 2 x BNC cables l = 75 cm incl.	11462-99	1
9	Screened cable, BNC, l = 750 mm	07542-11	3
10	Protection glasses for Nd:Yag laser	08581-20	1
11	Cleaning set for laser	08582-00	1
Optional:			
	Optical base plate in exp. case	08700.01	1

Set-up and procedure

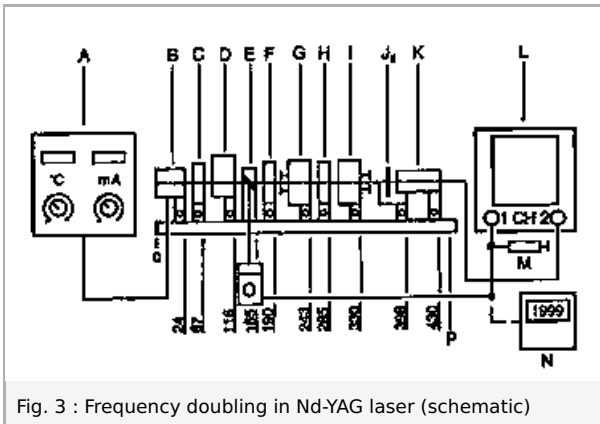

Fig. 3 : Frequency doubling in Nd-YAG laser (schematic)

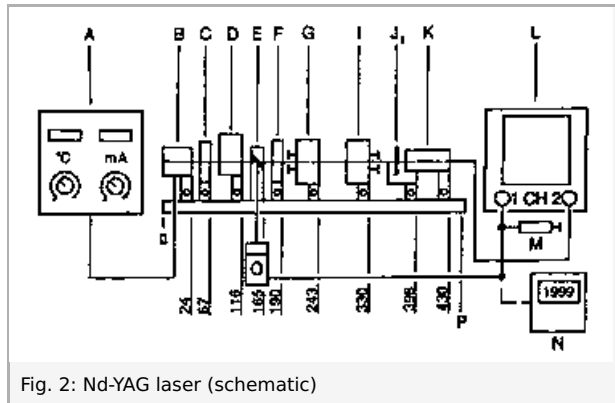

Fig. 2: Nd-YAG laser (schematic)

- A Control unit for semiconductor laser
- B Semiconductor laser unit with internal Peltier-Cooler
- C Collimator lenses set ($f = \text{approx. } 6 \text{ mm}$)
- D Chopper for laser beam with DC-motor, now included in A
- E Beamsplitter with high transmission for semiconductor laser beam, now included in A
- F Focusing lens, ($f = \text{approx. } 50 \text{ mm}$)
- G Nd-YAG crystal, in holder, one side with AR-coating/mirror
- H Frequency doubling crystal (KTP) in holder
- I Laser cavity mirror in holder, type of mirror changeable
- J₁ Filter-plate, long pass type, transmission for $> 850 \text{ nm}$
- J₂ Filter-plate, short pass type, transmission for $< 550 \text{ nm}$
- K PIN-diode detector head with internal battery (9 V)
- L Oscilloscope 20 MHz, 2 channels, sens.: 5 mV/unit
- N Multimeter with amplifier;
- O Sensor head for beam power measuring (silicon-diode)
- P Mounting plate for rail and components

It must be pointed out that the semiconductor diode laser (pump laser) must remain tuned to the strongest absorption line - at 808.4 nm - when performing the power measurements of the Nd-YAG laser. Since the injection current and the temperature (wavelength) cannot be modified independently, the characteristic curve, "injection current versus temperature" for $\lambda = 808.4 \text{ nm}$, first has to be traced.

This is done by eliminating the laser cavity mirror I and inserting the power meter O. For each variation of the injection current, the fluorescent power of the Nd-YAG rod, detected by O, is then brought to a maximum by adjustment of the temperature. The characteristic curve recorded in this way will be used later on to ensure a permanent absorption maximum for any type of injection current.

The laser mirror I is remounted on the optical bench while the PIN-detector K is brought into its position (Fig. 2) and connected to the oscilloscope. The modulator in unit A is switched on. The filter J₁ is put in front of the detector K so that only IR-pulses can be detected by K. The oscilloscope is brought to its most sensitive range.

The distance between the modules G and I should not exceed 50 mm. In order to ensure that the pump light is perfectly focused into the Nd-YAG rod, adjust collimator C and focus lens F. Collimator C should produce a parallel beam. Initially, it suffices to align the laser mirror I perpendicular to the optical axis just by sight. It is approximately aligned when the movable adjustment plate on the mirror holder is adjusted so that it is parallel to the fixed base plate. Please do not forget that the surfaces of the mirror and of the Nd-YAG rod must be carefully cleaned by using acetone and lens paper. The diode laser is then switched on and the current is set to the maximum possible value while a value of about 32°C is chosen for the temperature.

By means of the micrometer screws, modules G and I are then adjusted till the Nd-YAG laser begins to oscillate. The output power can be optimized by observing the IR-pulses on the oscilloscope while acting on the micrometer screws. Optimization may also be reached by a slight adjustment of focusing lens F. PIN detector K is then replaced by power meter O. For the demonstration of the frequency doubling, the mirror of module * with a transmission of 1.7% is replaced by a mirror of 0.02% transmission. This is a necessity, since frequency doubling can only occur if the IR-radiation intensity is sufficiently high within the laser cavity. The Nd-YAG laser modified in this way is readjusted and optimized in its output power. The KTP-crystal is then introduced into the cavity as shown in Fig. 3. Its position should be quite near to the Nd-YAG rod. The crystal can be rotated on its axis, tilted, and also moved in the X and Y directions. The KTP-crystal must be adjusted to provide the best phase matching, and thus producing the best conversion efficiency. Depending on how well the doubling crystal has been adjusted, a green beam will be emitted from the laser output. The intensity of the green light can be measured with the power meter O and the filter

plate J_2 in front of it.

Theory and evaluation

The principle of a four-level Nd-YAG laser system is shown in Fig. 4. Under radiation of light (optical pumping), transitions from ground state 1 to the upper level 4 occur. The reversed processes from state 4 to state 1 are prevented by very fast transitions from state 4 to state 3 without radiation. The laser transition takes place from level 3 into level 2 which is not thermally occupied. From here the Nd atoms relax again back to ground state 1.

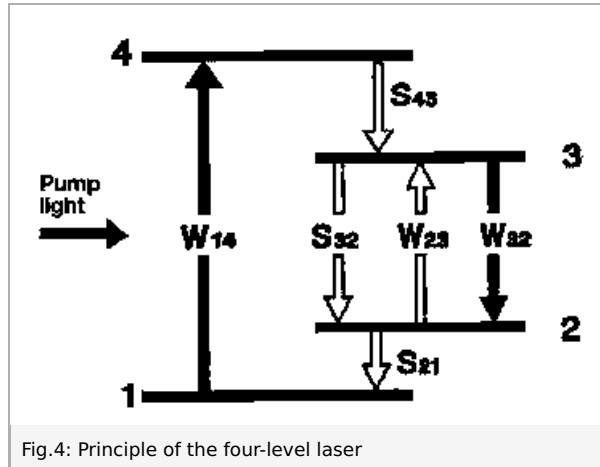

- W_{14} = probability of absorbing a pump photon
- S_{43} = probability of relaxation from state 4 to state 3 for each particle
- S_{32} = probability of the spontaneous emission of a photon
- W_{32} = probability of the induced emission of a photon
- W_{23} = probability of the induced absorption of a photon
- S_{21} = probability of relaxation from state 2 to state 1

The irradiation by light, which leads to the population of an otherwise empty state, is termed optical pumping. The emptying of a level occurs either with the emission of photons or without radiation. Transitions without radiation take place due to mechanical interactions such as shock or vibrations and they are also designated as relaxation. The number of transitions without radiation per second is termed the relaxation rate. Transitions in which photons are emitted occur spontaneously or are induced. Spontaneous transitions also occur without pumping processes. However, induced emissions only occur if a pumping process takes place. Rates are also stated here, one rate for spontaneous emission and another one for induced emission. Each state which can interact with one or more other states is labelled with this type of rate.

However, in Fig. 4 showing the principle, only the transition probabilities that are significant for the pump and laser processes are indicated.

All the designated levels are populated to some extent due to pumping. The extent to which each state is populated is given by the Nd atoms which are in the relevant state of excitation:

State 1	N_1
State 2	N_2
State 3	N_3
State 4	N_4

Under the realistic assumption made in this example that the Nd atoms only pass through the labelled excitation states, the sum of the population densities gives the Nd atoms which are available.

$$N_0 = N_1 + N_2 + N_3 + N_4$$

Student's Sheet

Printed: 04.12.2017 17:40:02 | P2260900

The desired laser oscillation can then, however, only be achieved if an adequate **population inversion** can be obtained between states 3 and 2. The conditions under which laser excitation occurs, together with how the laser behaves, can be predicted by a model of the rate equations.

The model describes the situation in a very simple but exact manner. Each of the constituent levels is regarded as a reservoir to which or from which "particles" flow. The "particles" represent the Nd atoms in their corresponding states of excitation. This method is used for each constituent state. Particle streams flowing to the level are given a positive sign, those flowing away are given a negative sign. The number of excited atoms per unit of time in state 3 is:

$$dN_3/dt/p = \eta \cdot W_{14} \cdot M_1 = W_p \cdot N_1 \quad \text{pump rate}$$

η is the pumping efficiency. The transition from state 4 should occur so fast that the laser output level 3 is pumped immediately afterwards and the extent to which state 4 is occupied is therefore $N_4 \approx 0$.

Another process affecting state 3 is spontaneous emission:

$$dN_3/dt/s = -\Gamma \cdot N_3 \quad \text{spontaneous rate}$$

where $\Gamma = 1/\tau_s \cdot \tau_s$ is the mean life of a photon before it is spontaneously emitted.

Finally, the induced processes occurring between states 3 and 2 under the influence of the laser field must also be considered. The relevant rates are proportional to the difference in the population numbers N_2 and N_3 and to the photon density p of the laser field. The effective cross-sectional area σ , for the emission or absorption of a photon arises as a constant of proportionality:

$$dN_3/dt/i = \sigma \cdot c \cdot p \cdot (N_2 - N_3) \quad \text{spontaneous rate}$$

$c = \text{velocity of light}$

Therefore the variation in the population density of level 3 with respect to time can be described as the sum of the separate rates:

$$dN_3/dt = \sigma \cdot c \cdot p \cdot (N_2 - N_3) - \Gamma \cdot N_3 + W_p \cdot N_1$$

Furthermore, the assumption is made that the transition from state 2 to state 1 is also so fast that only very few of the particles accumulate in state N_2 and therefore $N_2 \approx 0$. The total number N_0 of Nd atoms is therefore:

$$N_0 = N_1 + N_3$$

Since N_0 is constant, $dN_0/dt = 0$ and then $dN_1/dt = -dN_3/dt$. In total then, in the ground state, the variation of the population density N_1 with respect to time is:

$$dN_1/dt = -\sigma \cdot c \cdot p \cdot (N_2 - N_3) + \Gamma \cdot N_3 - W_p \cdot N_1.$$

It is important for the later laser process to know how the photon density on the laser transition 3 to 2, which is under consideration, varies with respect to time. With each "induced" absorption process, a photon is annihilated, and a photon is created with each induced emission process.

$$dp/dt/i = -\sigma \cdot c \cdot p \cdot (N_2 - N_3) \quad \text{induced}$$

Once created, a photon density level does not remain in a resonator, instead it reduces with the time constant τ_{ph} because photons are output at the mirrors or are lost in other ways.

$$dp/dt/v = -p/\tau_{ph} \quad \text{losses}$$

The complete variation of the photon density with respect to time is:

$$dp/dt = p \cdot (\sigma \cdot c \cdot (N_3 - N_2) - 1/\tau_p).$$

The population inversion $N_3 - N_2$ is designated as n for simplification. The variation of the population inversion with respect to time is obtained by the following expression:

$$dn/dt = -\sigma \cdot c \cdot p \cdot n - \Gamma \cdot n + W_p(N_1 - n) \quad (1)$$

and for the photon density:

$$dp/dt = -p \cdot (c \cdot \sigma \cdot n - 1/\tau_p) \tag{2}$$

The differential equations (1) and (2) form a pair of coupled conditional equations for the two unknown functions $n(t)$ and $p(t)$. The equations are nonlinear because they both contain the term $p \cdot n$. Analytical solutions are not known and one has to rely on computerized solutions.

When the system is in the state of equilibrium, i.e. for steadystate laser operation, the values for dn/dt and dp/dt are equal to zero. In this case, an expression for the population inversion is obtained immediately:

$$n = N_0 \cdot W_p / (c \cdot \sigma \cdot p + W_p + \Gamma).$$

When the laser is operated below or just at the threshold, no photon field is formed ($p = 0$). In this case, $W_p \ll \Gamma$ and the threshold inversion is:

$$n/p=0 = n_0 = N_0 \cdot W_p / \Gamma$$

This equation states that a four-level laser produces an inversion immediately on pumping. This is a particular advantage as opposed to other laser systems. Unfortunately, neither the photon density nor the pumping rate are directly accessible by measurement. However, the photon density is coupled to an easily measured quantity, i.e. the power applied in the pumping process. If the relationships between the photon density p and the corresponding intensity, as well as the resonator output and loss characteristics are considered, the output power P_{out} of a fourlevel laser can be obtained [1]:

$$P_{out} = \eta \cdot (E_{32}/E_{41}) \cdot T \cdot (T + L)^{-1} \cdot (P_p - P_{th}) \tag{3}$$

In this equation, E_{32} signifies the energy gap between states 3 and 2 (laser wavelength), E_{41} is the energy gap between states 4 and 1 (pump wavelength), T is the transmission of the output mirror, L is the loss in the resonator due to dispersion, absorption or refraction. P_p is the pump power and P_{th} is the threshold pump power. Above the threshold pump power P_{th} , the output power of the laser increases linearly with the pump power. The slope a of the straight line (Fig. 5) is one of the most important parameters of a laser and is termed the slope efficiency.

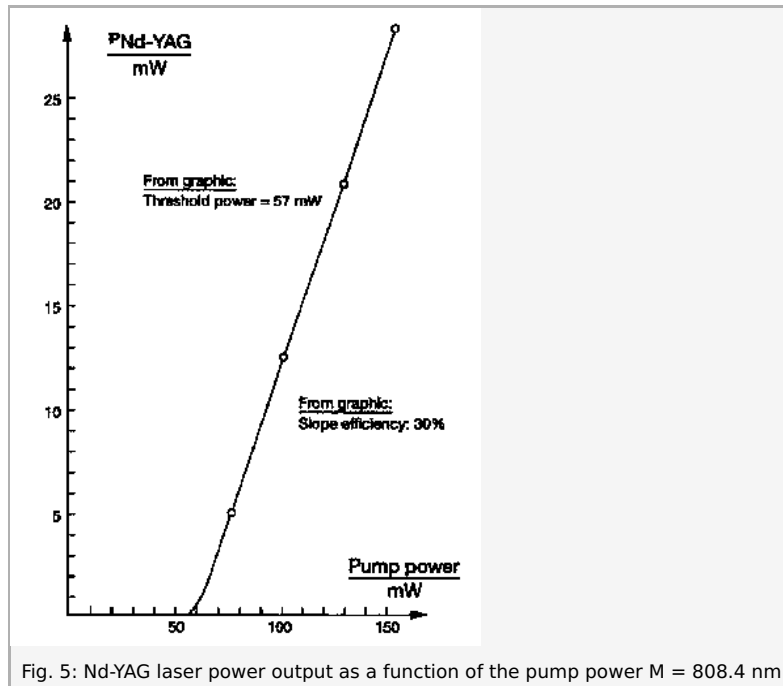

Fig. 5: Nd-YAG laser power output as a function of the pump power $M = 808.4 \text{ nm}$

The quantity E_{32}/E_{41} is also known as the laser quantum efficiency. It gives the energy ratio of a laser photon to the pump photon. For the Nd-YAG laser pumped by a diode laser, this is, for example, $810 \text{ nm}/1064 \text{ nm} = 0.76$. The value h is the quantum yield, but unfortunately both quantities are commonly known as the quantum efficiency.

For the laser designer, it is important to obtain the highest possible output power at the highest possible efficiency. Another important feature is that the transmission T for the resonator output mirror must be selected as large as possible, according to equation 4. However, this has the consequence that the threshold pump power P_{th} increases and the output power reduces according to equation 3. A compromise between equations 3 and 4 must therefore be found.

In the present case, a slope efficiency of 30% was found. The threshold power was determined to be 57 mW. For measuring P_a and P_p , the chopper D and beam splitter E must be ignored in Fig. 2. The power meter O was positioned between collimator C and focusing lens F for measuring P_p . For this reason, the injection current of the semiconductor diode laser was increased in

steps of 50 mA, beginning with an injection current of 200 mA. In plotting Fig. 5, a 28% power loss was accounted for due to the presence of the focusing lens (8%) and the Nd-YAG rod entry (20%).

The Nd-YAG laser output power P_a was measured with the power meter O in the position of the PIN detector K . For this reason, the injection current of the semiconductor diode laser was changed in the same way as before. At the same time, the temperature was continuously adjusted to ensure that the absorption within the Nd-YAG rod remained within the maximum for $\lambda = 808.4$ nm. Here, a 40% loss of IR-radiation caused by the filter J_1 was anticipated while performing Fig. 5.

The propagation of light in material is described by the two frequency dependent optical constants, the refractive index n and the absorption coefficient a . In normal linear optics, these quantities are independent of the intensity of the incident light. Reflection, refraction, propagation velocity and the weakening of the light are therefore constant for a given medium, and they are not dependent on the light intensity. This leads to two important principles which are applied throughout optics: the principles of optical superposition (interference) and the conservation of frequency.

These two assumptions only apply for relatively low light intensities, as supplied by normal light sources. With the high intensities of the laser, the superposition principle does not apply, nor does the conservation of frequency. Linear optics is therefore only a special case for low light intensities.

For a clear explanation of the interaction of light with material, it is helpful to imagine that the electrons are particles bound elastically to the nucleus. An electric field will deflect the electron out of its quiescent state, so producing a dipole. If the electric field is periodic, then the deflection (polarization) is also periodic and the dipole radiates with the same frequency as the electric field which has produced it. The polarization is therefore the basis for radiation in a medium. If the irradiating electric field becomes more intense, then the deflection of the electrons also increases.

The deflection depends not only on the field strength, but also on the spring constant of the bond binding the electron to the nucleus (susceptibility). If the field strength or susceptibility is high enough, the deflection is so large that the relationship between the force and the deflection is no longer linear. This is analogous to the deflection of a spring outside the range of proportionality (Hooke's Law). The polarization now contains a frequency component which was not present in the excitation field strength.

Since the polarization is the requirement for electromagnetic oscillation and is no longer harmonic, light waves are now produced with frequencies which are not contained in the excitation light. A Fourier analysis shows that, in this case, another oscillation occurs with double frequency as well as the fundamental oscillation.

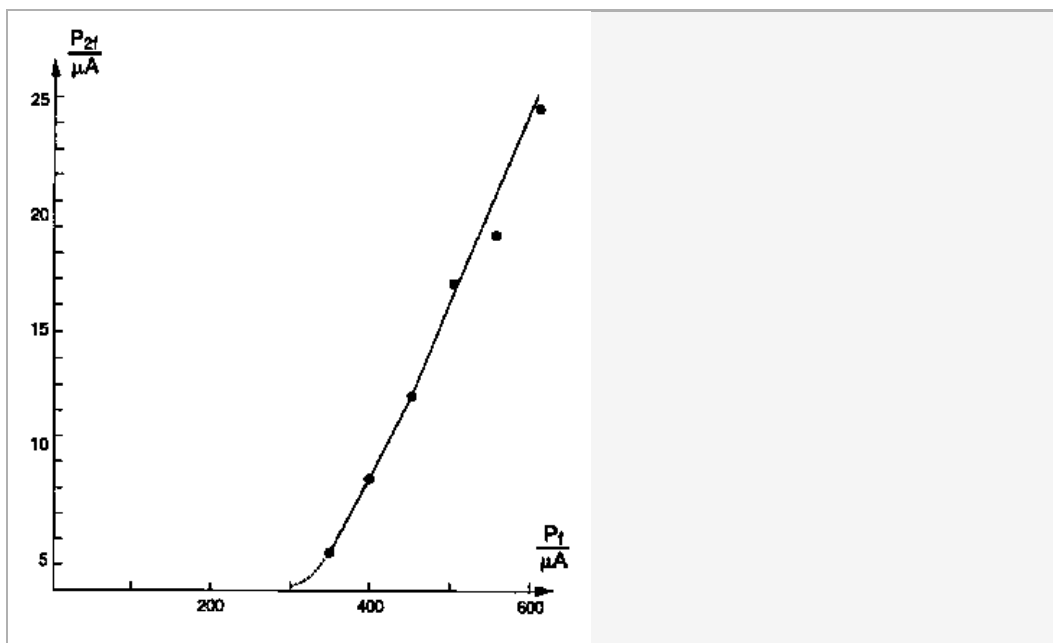

Fig. 6: Relationship between the power of the second harmonic P_{2f} and the power of the fundamental wave P_f .

If, for example, the beam of the Nd-YAG laser is radiated into a suitable doubling crystal, a beam at 532 nm, easily visible to the eye in the green region, is produced as well as the fundamental wave at 1064 nm. If the intensity of the green beam is high enough, this can in turn be converted to UV polarization at 266 nm using another crystal. Limits are only set by availability of suitable doubling crystals.

A quadratic relationship exists between the power P_1 of the fundamental wave and the beam power P_{2f} of the second harmonic.

In verifying this relationship, the injection current of the diode laser can be taken as proportional to P_1 . P_{2f} is measured with the power meter O and expressed in microamperes. Fig. 6 shows the experimental results.