

Specific heat capacity of water with SMARTsense

(Item No.: P1043969)

Curricular Relevance

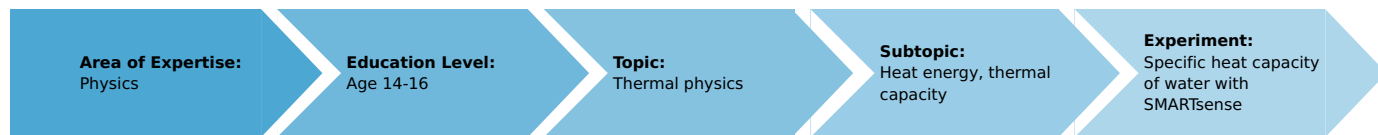

Difficulty



Intermediate

Preparation Time



10 Minutes

Execution Time



10 Minutes

Recommended Group Size



2 Students

Additional Requirements:

- Tablet
- measureApp

Experiment Variations:

Keywords:

specific heat capacity of water, electric power, amount of heat, temperature change

Information for Teachers

Information for teachers

The specific heat capacity of water is to be measured in this experiment. The heat capacity of the calorimeter itself is disregarded here but should be mentioned as a systematic error (question 8.). It is assumed here that the heat uptake of a substance is proportional to the amount of the substance and is independent of the temperature. It is also assumed that the electric power is completely converted to heat and that the relation between the electric energy and the amount of heat is known.

Caution!

The heating coil must dip into water before it is connected to the power supply!

Notes on set-up and procedure

- Only the lower heating power corresponding to 6 V \sim is to be used here, so that measurement errors due to uneven distribution of the heat and insulation losses of the calorimeter are irrelevant.
- Large temperature differences lead here to large measurement errors - we therefore recommend that all parts and the water are at (the same) room temperature.

The current and the voltage can also be measured without replugging the measuring instrument when interconnection is made as shown in Figs. 1a and 1b. In this case use measuring ranges 10 A \sim and 10 V \sim .

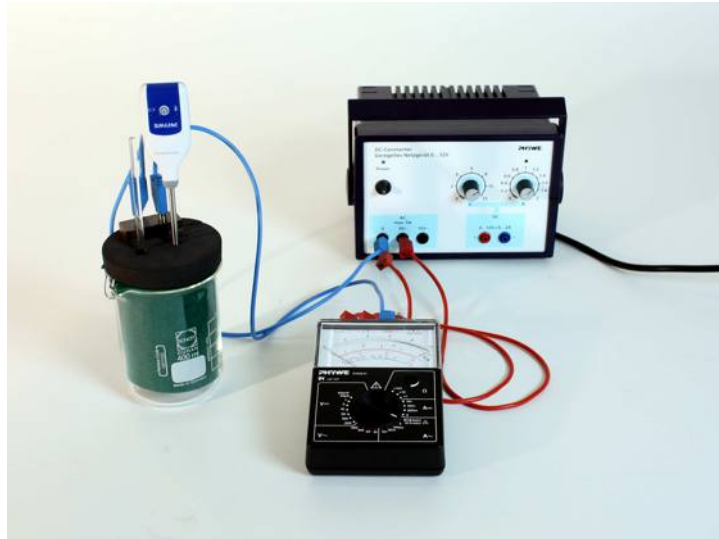

Fig. 1a: Set-up incase of no replugging.

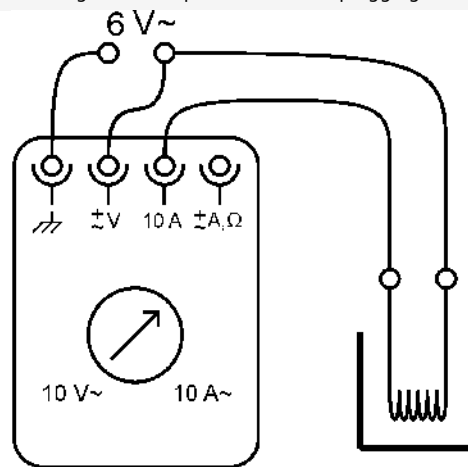

Fig. 1b: Switching diagram for alternative measurement.

Specific heat capacity of water with SMARTsense (Item No.: P1043969)

Introduction

When the sun sets in summer, it becomes colder really quick in the grass while it stays nicely warm on the patio near the house. This effect becomes possible as different materials store thermal energy in a different way. Scientists call this property the specific heat capacity of a material. Using the specific heat capacity it becomes possible to say, how much energy is needed to heat up for example water for a certain amount. That is exactly what you are about to observe. In this experiment you will determine how much energy you need to heat up water.



Task

How are amount of heat, heat capacity and change in temperature related?

Heat 200 ml of water with an electric heating coil. Measure the increase in temperature in dependence on time. Determine the electric power of the heating coil and so the amount of heat taken up per degree increase in temperature.

Equipment



Position No.	Material	Order No.	Quantity
1	Cobra SMARTsense - Temperature, - 40 ... 120 °C	12903-00	1
2	PHYWE power supply, 230 V, DC: 0...12 V, 2 A / AC: 6 V, 12 V, 5 A	13506-93	1
3	Lid for student calorimeter	04404-01	1
4	Agitator rod	04404-10	1
5	Heating coil with sockets	04450-00	1
6	Felt sheet, 100 x 100 mm	04404-20	2
7	Erlenmeyer wide neck,boro.,250ml	46152-00	1
8	Beaker, low, BORO 3.3, 250 ml	46054-00	1
9	Beaker, low, BORO 3.3, 400 ml	46055-00	1
10	Graduated cylinder 100 ml, PP transparent	36629-01	1
11	Pipette with rubber bulb	64701-00	1
12	Connecting cord, 32 A, 500 mm, blue	07361-04	2
13	Connecting cord, 32 A, 500 mm, red	07361-01	2
14	Multi-range meter, analogue	07028-01	1
Additionally			
	Tablet PC		1
	PHYWE measureAPP		1

Android

iPad



Set-up and procedure

Set-up

- Fill the Erlenmeyer flask with water (as stock of water at room temperature).
- Make up a thermally insulating vessel (calorimeter) using two beakers (250 ml and 400 ml) and two felt sheets, by covering the rim of the larger beaker with the felt and then inserting the smaller beaker.
- Carefully ease the heating coil through the slit in the calorimeter lid.
- Push the agitator rod up through the appropriate hole in the lid from below.
- Ensure that the power supply is still switched off.





Fig. 1: Experimental set-up

Procedure

Caution!

The heating coil must be in water when a 12 V voltage is applied, otherwise it will burn out!

- Turn on the Cobra SMARTsense-Temperature. Open the „measure“ app  and select the temperature sensor.
- Choose 1 Hz as a sampling rate and select the diagram-window.
- Measure 200 ml water from the Erlenmeyer flask into the graduated cylinder (measure exactly using the pipette) and pour it into the calorimeter. Record the amount of water.
- Fit the lid with heating coil and agitator rod on the calorimeter and insert the temperature sensor so far through the remaining hole in the lid that it dips in the water but does not touch the bottom.
- Use the connecting cords to connect the heating coil and the multi-range meter to the 6 V~ alternating voltage output (power supply off!) as shown in Fig. 2a. Select measuring range 3 A~.
- Stir and wait until the temperature remains constant.
- Simultaneously start measured value recording in measure  and switch the power supply on. Measured temperature values will now be recorded every 5 seconds.
- Carefully stir the water in the calorimeter during measurement, so that the heat is uniformly distributed. Begin stirring immediately after the start of measurement.
- End measurement with  after 350 s and save the data for further analysis.
- Record the amperage, then switch the power supply off.
- Use the connecting cords to connect the heating coil and the multi-range meter to the 6 V~ alternating voltage output as shown in Fig. 2b. Select measuring range 10 V~.
- Switch the power supply on, record the voltage. Switch the power supply off!

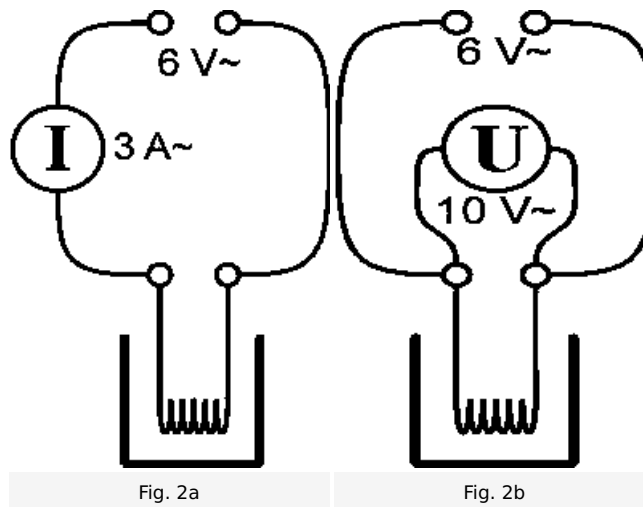

Evaluation

Select the "Regression" tool in the app and fit a line through the measured data. The slope of the curve is the temperature change rate and has the unit °C/s.



Fig. 3: Behaviour of temperature against time with electric heating, analysed with the "Regression" tool in the measureApp.

Report: Specific heat capacity of water with SMARTsense

Result - Table 1 (4 points)

Fill in the measurement record (Table 1) (water has a density of 1.00 g/ml)

Mass of water $m_{\text{Water}} / \text{g}$	200	1
Electric voltage U / V	6.0	1
Electric amperage I / A	2.1	1
Measured temperature change rate $^{\circ}\text{C/s}$	0.015	1

Result - Table 2 (5 points)

1. For electric power, $P = U \cdot I$ whereby the unit of $[P] = W = J/s$. What is the value of the electric power? Enter this in Table 2.
2. What is the value of the amount of heat ΔQ with the unit $[\Delta Q] = J$, that is emitted each second by the heating coil having this electric power and is taken up by the water? Enter this in Table 2.
3. With proper stirring, the amount of heat is distributed evenly throughout the whole mass of water m_{water} . Which amount of heat is taken up by each gram of water, i.e. what is the specific heat quantity $\Delta q = \Delta Q / m_{\text{water}}$ in the calorimeter? Enter this in Table 2.
4. How large is the increase in temperature $\Delta\theta$ after one second? Enter this in Table 2.
5. Dividing the specific heat quantity Δq by the temperature change $\Delta\theta$ gives the specific heat capacity $c = \Delta q / \Delta\theta$. Calculate this for water and enter it in Table 2.

Remarks

This calculation is of course not only valid for steps of one second but also in general for the specific heat capacity:

$$c = \frac{P}{m \cdot \frac{\Delta\theta}{\Delta t}}, \text{ whereby } \frac{\Delta\theta}{\Delta t} \text{ is the temperature change rate.}$$

For the change in heat content ΔQ of a substance of mass m and specific heat capacity c , when the temperature of it changes by $\Delta\theta$, we also have:

$$\Delta Q = c \cdot m \cdot \Delta\theta.$$

Electric power P / J/s	12.6	1
Amount of heat ΔQ after one second in J	12.6	1
Specific heat $\Delta Q_{\text{spec}} = \Delta Q / m_{\text{Water}}$ in J/g	0.063	1
Temperature change after 1 sec. $\Delta\theta$ in °C	0.015	1
Specific heat capacity $c_{\text{Water}} = \Delta Q_{\text{spec}} / \Delta\theta$ in J/(g·°C)	4.2	1

Evaluation - Question 1 (5 points)

Why is the value measured here for the heat capacity of water greater than it actually is? Which two sources of error predominate?

.....

.....

.....

.....

Evaluation - Question 2 (2 points)

The greater the heat capacity of a substance, the the amount of heat that is required to heat the substance by 1 °C.
The smaller the heat capacity of a substance, the it heats up with a given heating.

Evaluation - Question 3 (5 points)

Use the measured value that you have determined for the heat capacity of water to calculate:
How long must an electric kettle be heated with 1000 Watt (1 kW) for a litre of water to be heated up from 15 °C to 95 °C?
How many J or kWh of electric energy has the electric heater consumed in doing this?
(1 kWh = 3600 kWs = 3.6 MJ)

.....

.....

.....

.....

Evaluation - Question 4 (5 points)

A person needs 80 litres of water for a shower. The instant water heater heats the water from 15 °C to 40 °C. Which amount of heat is required for this?

Remark:

The heat capacity of water was previously used to define the unit for the amount of heat. The amount of heat that is required to heat 1 ml of water from 14.5 °C to 15.5 °C was taken as an amount of heat of one calorie (cal). The relationship 1 kcal = 4.186 kJ gives the literature value for the heat capacity of water. A daily diet of 2500 kcal so corresponds to the intake of 10.5 MJ or 2.9 kWh (compare with the result).

.....

.....

.....

.....