



**Okta 2000 ATEX, Roots pump,  
230/400 V, 50 Hz | 265/460 V, 60  
Hz | Ex II 2/2G Ex h IIB T3 Gb X +5  
°C ≤ Ta ≤ +40 °C**



Similar Image

## Okta 2000 ATEX, Roots pump, 230/400 V, 50 Hz | 265/460 V, 60 Hz | Ex II 2/2G Ex h IIB T3 Gb X +5 °C T<sub>a</sub> +40 °C

- High-performance Roots pump with a pumping speed of 1080 to 2585 m<sup>3</sup>/h
- Blocked overflow valve
- For operation with frequency converter or switch-on at a defined backing pressure, i.e. for continuous processes
- With 3-phase motor II 2G Ex de IIC T4
- Pumps are hermetically sealed (leak rate  $\leq 1 \cdot 10^{-6}$  Pa m<sup>3</sup>/s) – risk of zone entrainment is minimized
- Pressure surge resistance according to EN 1333, PN level 16
- Explosion safety due to reliable construction and temperature monitoring – installation without additional flame arrester possible
- Note: For the operation of the pumps, the terms of the operating instructions apply. We are pleased to provide you with the right solution for your application!
- Working conditions: Pump is inside and outside suitable for operation in equipment class II, equipment category 2(G) for gases and vapors of explosion class IIA and IIB, temperature class T3 according directive 2014/34/EU

Pumps are suitable for operation with FC.

Other voltages 50 Hz: 200 V, 220/380 V, 380/660 V, 415 V and 60 Hz: 200 V, 220/380 V, 230/400 V, 380/ 660 V, 400/690 V, 440/760 V, 480 V are available.

Stainless steel 1.4059 available on request.

Available as category 2 marked equipment according to directive 2014/34/EU on request.

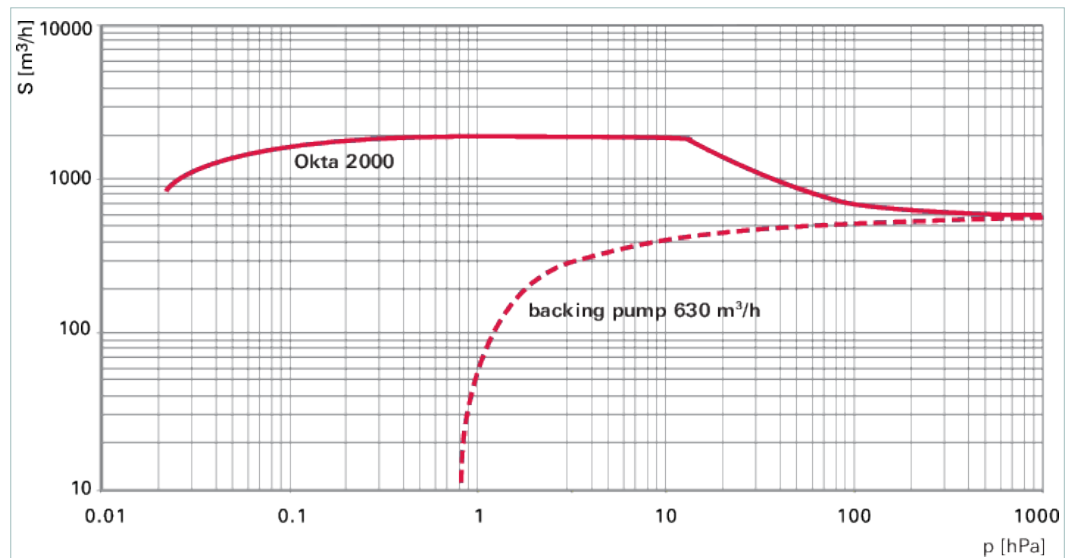

## Dimensions

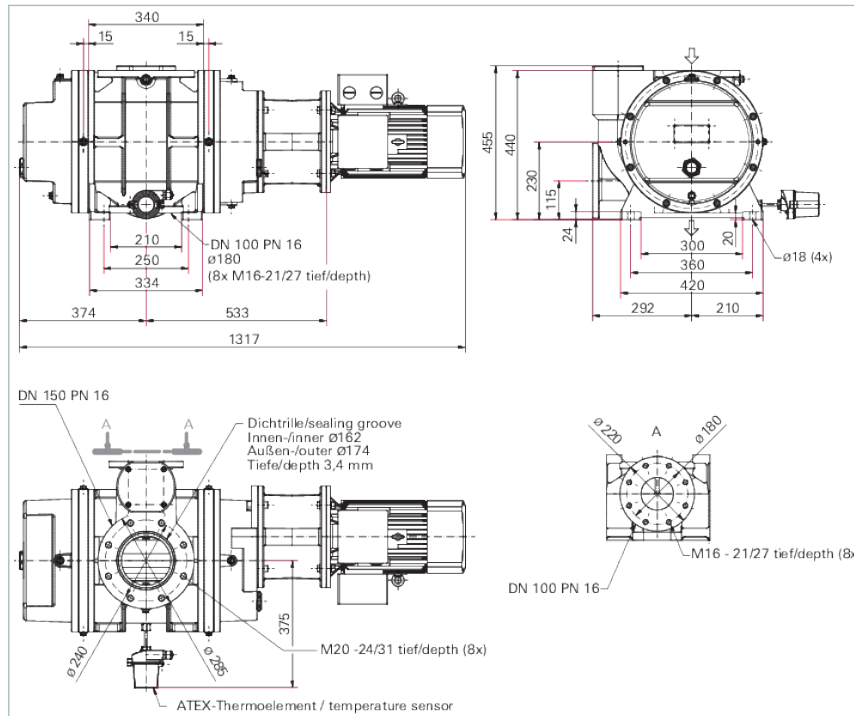

A	1356 mm
B	533 mm
C	455 mm
D	292 mm

## Technical Data

**Okta 2000 ATEX, Roots pump, 230/400 V, 50 Hz | 265/460 V, 60 Hz | Ex II 2/2G Ex h IIB T3 Gb X +5 °C T<sub>a</sub> +40 °C**

Ambient temperature	5-40 °C   41-104 °F   278-313 K
Cooling method, standard	Air
Dimensions (L x W x H)	1,356 x 502 x 458 mm   53.39 x 19.76 x 18.03 inch
Emission sound pressure level (EN ISO 2151) at intake pressure 10 hPa	75 dB(A)
Emission sound pressure level (EN ISO 2151) at intake pressure 1 hPa	72 dB(A)
Flange (in)	DN 150 PN 16
Flange (out)	DN 100 PN 16
Leak rate	1 · 10 <sup>-6</sup> Pa m <sup>3</sup> /s   7.5 · 10 <sup>-6</sup> Torr l/s   1 · 10 <sup>-5</sup> mbar l/s
Mains requirement: voltage 50 Hz	230/400 V
Mains requirement: voltage 60 Hz	265/460 V
Motor protection	3TF
Nominal pumping speed	1,075-2,585 m <sup>3</sup> /h   632.75-1,521.53 cfm   17,916.67-43,083.33 l/min
Nominal pumping speed at 50 Hz	2,155 m <sup>3</sup> /h   1,268.43 cfm   35,916.67 l/min
Nominal pumping speed at 60 Hz	2,585 m <sup>3</sup> /h   1,521.53 cfm   43,083.33 l/min
Nominal pumping speed max.	2,585 m <sup>3</sup> /h   1,521.53 cfm   43,083.33 l/min
Nominal pumping speed min.	1,075 m <sup>3</sup> /h   632.75 cfm   17,916.67 l/min
Nominal rotation speed at 50 Hz	3,000 rpm   3,000 min <sup>-1</sup>
Nominal rotation speed at 60 Hz	3,600 rpm   3,600 min <sup>-1</sup>
Operating fluid	P3
Operating fluid filling	5 l
Protection category	IP55
Rated power 50 Hz	5.5 kW
Rated power 60 Hz	6.3 kW
Rotation speed	1,500-3,600 rpm   1,500-3,600 min <sup>-1</sup>

Technical Data	Okta 2000 ATEX, Roots pump, 230/400 V, 50 Hz   265/460 V, 60 Hz   Ex II 2/2G Ex h IIB T3 Gb X +5 °C T <sub>a</sub> +40 °C
Version	Ex II 2/2G Ex h IIB T3 Gb X +5 °C ≤ T <sub>a</sub> +40 °C with motor, magnetic coupling and blocked over flow-valve
Voltage: Range	± 5 %
Weight: with motor	390 kg   859.79 lb

Order number	
Okta 2000 ATEX	PP W63 400

Accessories	
<b>Flanges/Ports Blank flanges</b>	
Blank flange set for Okta 1000/M/ATEX   Okta 2000/M/ATEX, DN PN16, (stainless steel)	PP 043 885 -T
<b>Mounting Screw sets</b>	
Screw Set for Okta 2000/M/ATEX, DN PN16, Zinc-Plated Steel	PP 144 117 -T
<b>Mounting Sealing kits</b>	
Seal Kit (FKM) for Okta 1000/M/ATEX   Okta 2000/M/ATEX, DN PN16	PP 043 886 -T
<b>Operating Fluids Mineral oil</b>	
P3, mineral oil, 0.5 l	PK 001 136 -T
P3, mineral oil, 1 l	PK 001 106 -T
P3, mineral oil, 20 l	PK 001 108 -T
P3, mineral oil, 5 l	PK 001 107 -T

## **VACUUM SOLUTIONS FROM A SINGLE SOURCE**

Pfeiffer Vacuum stands for innovative and custom vacuum solutions worldwide, technological perfection, competent advice and reliable service.

## **COMPLETE RANGE OF PRODUCTS**

From a single component to complex systems:

We are the only supplier of vacuum technology that provides a complete product portfolio.

## **COMPETENCE IN THEORY AND PRACTICE**

Benefit from our know-how and our portfolio of training opportunities!

We support you with your plant layout and provide first-class on-site service worldwide.

Are you looking for a  
perfect vacuum solution?  
Please contact us:

**Pfeiffer Vacuum GmbH**  
Headquarters · Germany  
T +49 6441 802-0  
info@pfeiffer-vacuum.de

[www.pfeiffer-vacuum.com](http://www.pfeiffer-vacuum.com)

All data subject to change without prior notice.

**PFEIFFER**  **VACUUM**