

**Hepta 630 P, 190-208/220-240/380-
415 V, 50 Hz**



Similar Image

Hepta 630 P, 190-208/220-240/380-415 V, 50 Hz

- High-performance screw pump with a pumping speed of 630 m³/h
- Ideal solution for all areas in which oil-free vacuum is required
- For application in the low and medium vacuum

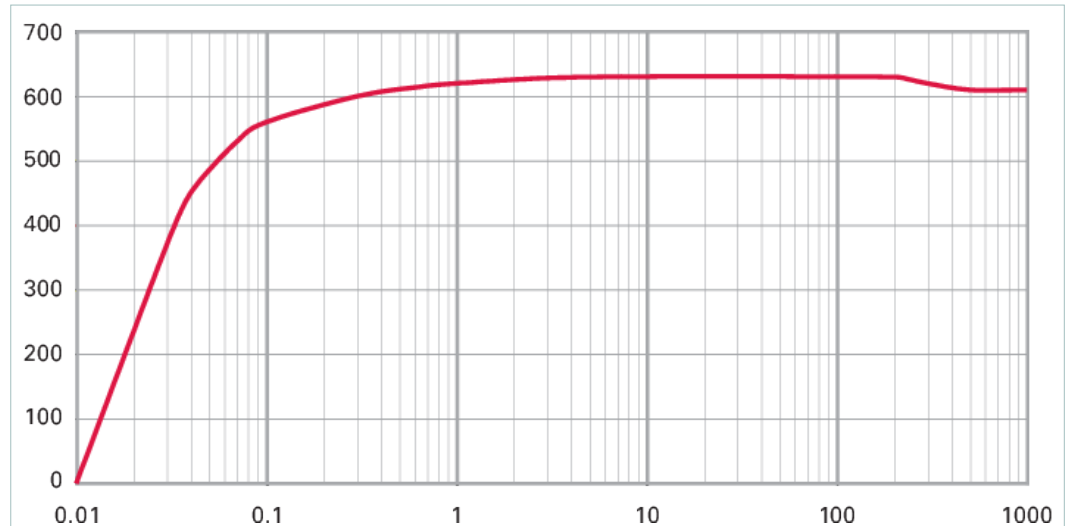

Dimensions

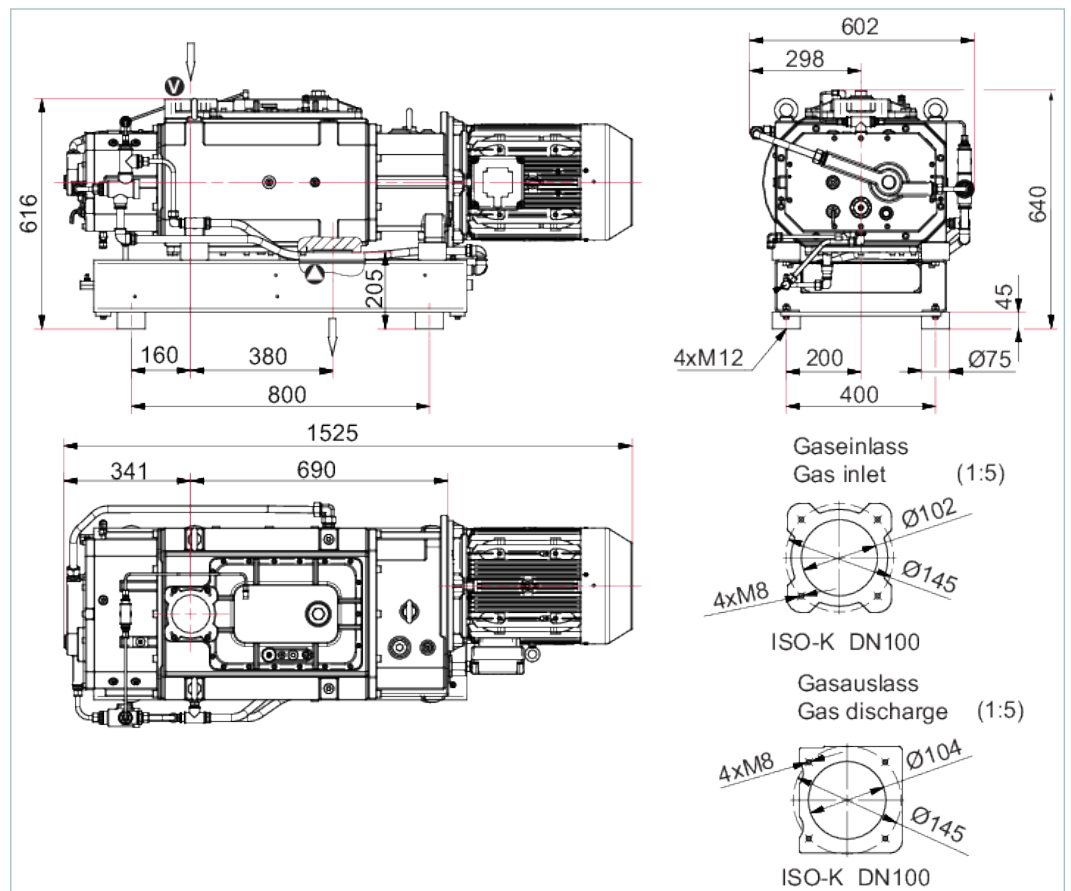

Technical Data	Hepta 630 P, 190-208/220-240/380-415 V, 50 Hz
Ambient temperature	5-50 °C 41-122 °F 278-323 K
Cooling water pressure	1,000-6,000 hPa 750-4,500 Torr 1,000-6,000 mbar
Cooling water temperature	10-30 °C 50-86 °F 283-303 K
Flange (in)	DN 100 ISO-K
Flange (out)	DN 100 ISO-K
Mains requirement: voltage 50 Hz	190 – 208/220 – 240/380 – 415 V
Motor rating 50 Hz	15 kW
Nominal pumping speed at 50 Hz	630 m ³ /h
Nominal rotation speed at 50 Hz	3,000 rpm 3,000 min ⁻¹
Operating fluid	D1, synthetic diester based oil
Operating fluid filling	2 l
Protection category	IP55
Sound pressure level	70 dB(A)
Ultimate pressure	< 1 · 10 ⁻² hPa < 7.5 · 10 ⁻³ Torr < 1 · 10 ⁻² mbar
Weight	550 kg 1,212.53 lb

Order number	
Hepta 630 P	PU V62 430

Accessories	
Operating fluid	
D1, synthetic diester based oil, 1 l	PK 005 875 -T
D1, synthetic diester based oil, 5 l	PK 005 876 -T
Dust separator	
SAS 100 dust separator, DN 100 ISO-K, polyester filter	PK Z60 512
Exhaust silencer	
Exhaust silencer DN 80, PN 16, DIN 2576 for Hepta 630 P	PU Z00 103
Check valve	
Check valve Hepta 400 P/630 P	PU Z00 202
PTC resistor tripping unit for PTC resistor sensor	
PTC-resistor tripping device	P 4768 052 FQ

VACUUM SOLUTIONS FROM A SINGLE SOURCE

Pfeiffer Vacuum stands for innovative and custom vacuum solutions worldwide, technological perfection, competent advice and reliable service.

COMPLETE RANGE OF PRODUCTS

From a single component to complex systems:

We are the only supplier of vacuum technology that provides a complete product portfolio.

COMPETENCE IN THEORY AND PRACTICE

Benefit from our know-how and our portfolio of training opportunities!

We support you with your plant layout and provide first-class on-site service worldwide.

Are you looking for a
perfect vacuum solution?
Please contact us:

Pfeiffer Vacuum GmbH
Headquarters · Germany
T +49 6441 802-0
info@pfeiffer-vacuum.de

www.pfeiffer-vacuum.com

All data subject to change without prior notice.

PFEIFFER  **VACUUM**