



Hepta 200 P, 220-230/416-460 V, 60 Hz



Similar Image

Hepta 200 P, 220-230/416-460 V, 60 Hz

- High-performance screw pump with a pumping speed of 265 m³/h
- Ideal solution for all areas in which oil-free vacuum is required
- Internal compression is gentle to bearings and seals
- For applications in the low and medium vacuum

Dimensions

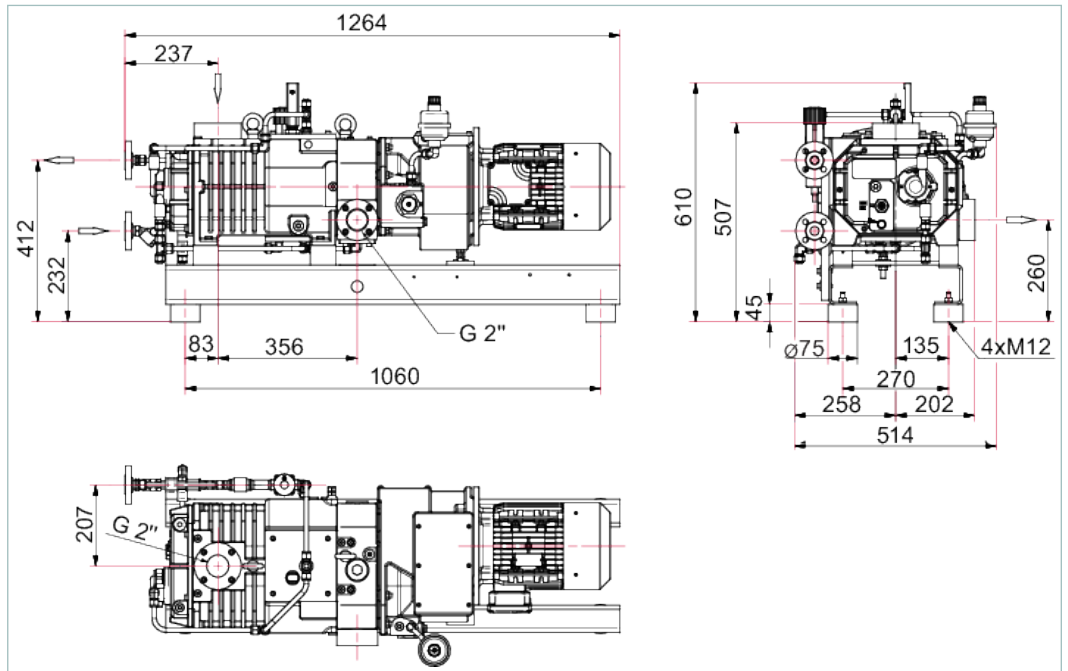

Technical Data	Hepta 200 P, 220-230/416-460 V, 60 Hz
Ambient temperature	0-50 °C 32-122 °F 273-323 K
Cooling water consumption	120 – 360 l/h
Cooling water consumption, max	360 l/h
Cooling water consumption, min	120 l/h
Cooling water pressure	3,000-6,000 hPa 2,250-4,500 Torr 3,000-6,000 mbar
Cooling water temperature	10-25 °C 50-77 °F 283-298 K
Flange (in)	G 2"
Flange (out)	G 2"
Mains requirement: voltage 60 Hz	220 – 230/416 – 460 V
Motor rating 60 Hz	7.6 kW
Nominal pumping speed at 60 Hz	265 m ³ /h
Nominal rotation speed at 60 Hz	3,600 rpm 3,600 min ⁻¹
Operating fluid	D1, synthetic diester based oil
Operating fluid filling	1.55 l
Protection category	IP55
Sound pressure level	76 dB(A)
Ultimate pressure	< 1 · 10 ⁻² hPa < 7.5 · 10 ⁻³ Torr < 1 · 10 ⁻² mbar
Weight	319 kg 703.27 lb

Order number	
Hepta 200 P	PU V22 422

Accessories	
Operating fluid	
D1, synthetic diester based oil, 1 l	PK 005 875 -T
D1, synthetic diester based oil, 5 l	PK 005 876 -T
Exhaust silencer	
Exhaust silencer DN 50, PN 16, DIN 2576 for Hepta 200 P, 300 P	PU Z00 101
Check valve	
Check valve Hepta 200 P/300 P	PU Z00 201
PTC resistor tripping unit for PTC resistor sensor	
PTC-resistor tripping device	P 4768 052 FQ
Dust separator	
SAS 63 dust separator, DN 63 ISO-K, polyester filter	PK Z60 511
Other	
Flange DN 63 ISO-K/G 2"	PK 100 059

VACUUM SOLUTIONS FROM A SINGLE SOURCE

Pfeiffer Vacuum stands for innovative and custom vacuum solutions worldwide, technological perfection, competent advice and reliable service.

COMPLETE RANGE OF PRODUCTS

From a single component to complex systems:

We are the only supplier of vacuum technology that provides a complete product portfolio.

COMPETENCE IN THEORY AND PRACTICE

Benefit from our know-how and our portfolio of training opportunities!

We support you with your plant layout and provide first-class on-site service worldwide.

Are you looking for a
perfect vacuum solution?
Please contact us:

Pfeiffer Vacuum GmbH
Headquarters · Germany
T +49 6441 802-0
info@pfeiffer-vacuum.de

www.pfeiffer-vacuum.com

All data subject to change without prior notice.

PFEIFFER  **VACUUM**