



# Hepta 200 P, 190-208/380-415 V, 50 Hz



Similar Image

## Hepta 200 P, 190-208/380-415 V, 50 Hz

- High-performance screw pump with a pumping speed of 220 m<sup>3</sup>/h
- Ideal solution for all areas in which oil-free vacuum is required
- Internal compression is gentle to bearings and seals
- For applications in the low and medium vacuum

### Dimensions

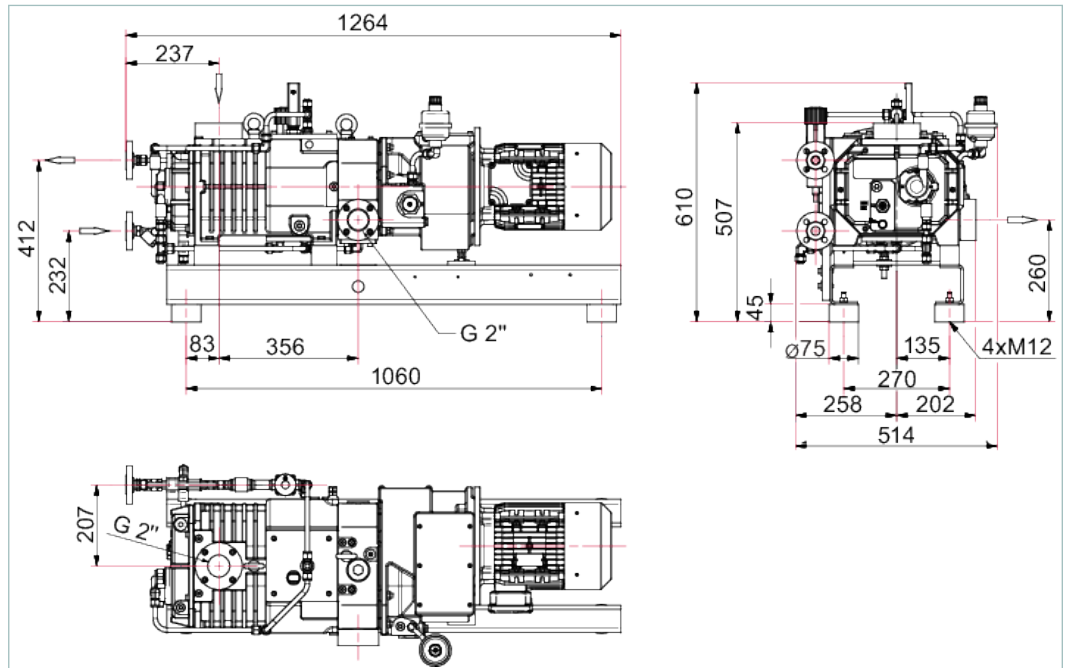

| Technical Data                   | Hepta 200 P, 190-208/380-415 V, 50 Hz   |
|----------------------------------|---|
| Ambient temperature              | 0-50 °C   32-122 °F   273-323 K   |
| Cooling water consumption        | 120 – 360 l/h   |
| Cooling water consumption, max   | 360 l/h   |
| Cooling water consumption, min   | 120 l/h   |
| Cooling water pressure           | 3,000-6,000 hPa   2,250-4,500 Torr   3,000-6,000 mbar                                     |
| Cooling water temperature        | 10-25 °C   50-77 °F   283-298 K   |
| Flange (in)                      | G 2"  |
| Flange (out)                     | G 2"  |
| Mains requirement: voltage 50 Hz | 190 – 208/380 – 415 V   |
| Motor rating 50 Hz               | 6 kW  |
| Nominal pumping speed at 50 Hz   | 220 m <sup>3</sup> /h   |
| Nominal rotation speed at 50 Hz  | 3,000 rpm   3,000 min <sup>-1</sup>   |
| Operating fluid                  | D1, synthetic diester based oil   |
| Operating fluid filling          | 1.55 l  |
| Protection category              | IP55  |
| Sound pressure level             | 71 dB(A)  |
| Ultimate pressure                | < 5 · 10 <sup>-2</sup> hPa   < 3.75 · 10 <sup>-2</sup> Torr   < 5 · 10 <sup>-2</sup> mbar |
| Weight                           | 319 kg   703.27 lb  |

| Order number |            |
|--------------|------------|
| Hepta 200 P  | PU V22 420 |

| <b>Accessories</b>   |                      |
|--|----------------------|
| <b>Operating fluid</b>   |                      |
| D1, synthetic diester based oil, 1 l                           | <b>PK 005 875 -T</b> |
| D1, synthetic diester based oil, 5 l                           | <b>PK 005 876 -T</b> |
| <b>Exhaust silencer</b>  |                      |
| Exhaust silencer DN 50, PN 16, DIN 2576 for Hepta 200 P, 300 P | <b>PU Z00 101</b>    |
| <b>Check valve</b>   |                      |
| Check valve Hepta 200 P/300 P                                  | <b>PU Z00 201</b>    |
| <b>PTC resistor tripping unit for PTC resistor sensor</b>      |                      |
| PTC-resistor tripping device                                   | <b>P 4768 052 FQ</b> |
| <b>Dust separator</b>  |                      |
| SAS 63 dust separator, DN 63 ISO-K, polyester filter           | <b>PK Z60 511</b>    |
| <b>Other</b>   |                      |
| Flange DN 63 ISO-K/G 2"  | <b>PK 100 059</b>    |

## **VACUUM SOLUTIONS FROM A SINGLE SOURCE**

Pfeiffer Vacuum stands for innovative and custom vacuum solutions worldwide, technological perfection, competent advice and reliable service.

## **COMPLETE RANGE OF PRODUCTS**

From a single component to complex systems:

We are the only supplier of vacuum technology that provides a complete product portfolio.

## **COMPETENCE IN THEORY AND PRACTICE**

Benefit from our know-how and our portfolio of training opportunities!

We support you with your plant layout and provide first-class on-site service worldwide.

Are you looking for a  
perfect vacuum solution?  
Please contact us:

**Pfeiffer Vacuum GmbH**  
Headquarters · Germany  
T +49 6441 802-0  
info@pfeiffer-vacuum.de

[www.pfeiffer-vacuum.com](http://www.pfeiffer-vacuum.com)

All data subject to change without prior notice.

**PFEIFFER**  **VACUUM**