

INTEGRATED DOVETAIL CHANNELS
ALLOW MULTIPLE XRN25 SERIES STAGES
TO BE STACKED INTO AN X/Y CONFIGURATION

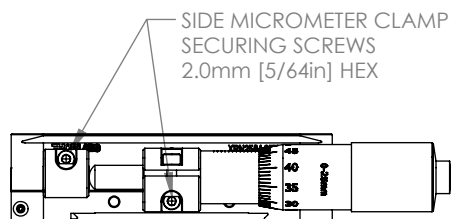

AUXILIARY SIDE VIEW

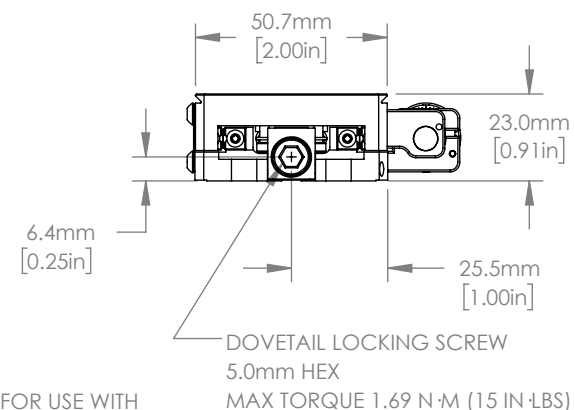
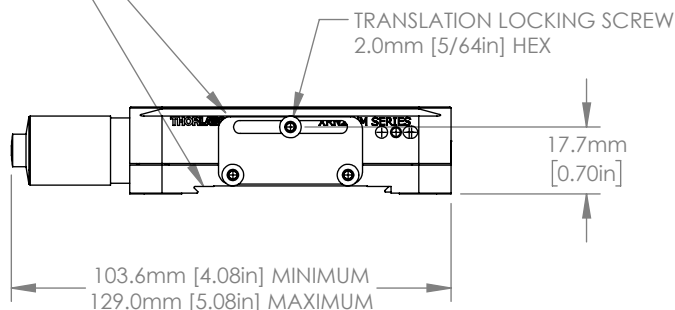
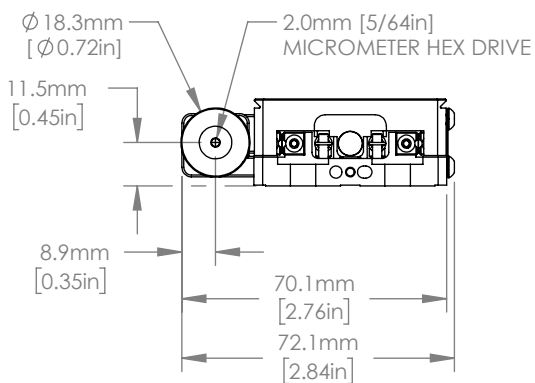
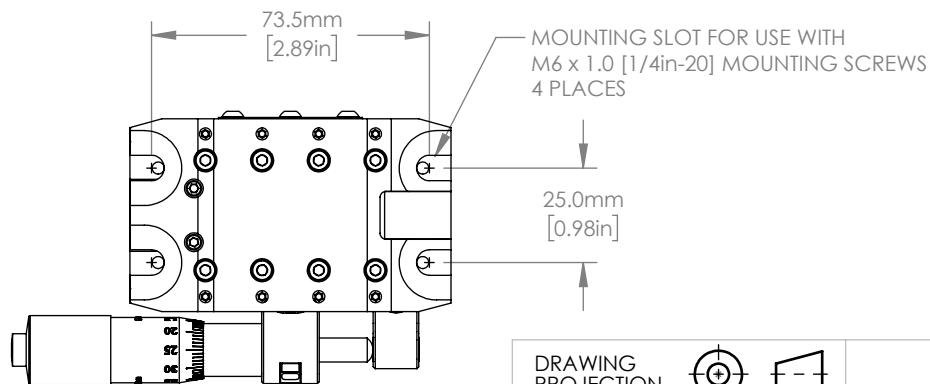

AUXILIARY BOTTOM VIEW

FOR INFORMATION ONLY
NOT FOR MANUFACTURING PURPOSES

DRAWING PROJECTION					THORLABS www.thorlabs.com	
NAME	DATE	METRIC COMPACT 25mm CROSSED ROLLER SIDE ACTUATED TRANSLATION STAGE				
DRAWN	CS	28/MAR/17	MATERIAL		REV	
APPROVAL	BJ	28/MAR/17	N/A		C	
COPYRIGHT © 2017 BY THORLABS					ITEM #	APPROX WEIGHT
VALUES IN PARENTHESIS ARE CALCULATED AND MAY CONTAIN ROUND OFF ERRORS					XRN25P/M	0.34 kg