

INTEGRATED DOVETAIL CHANNELS
ALLOW MULTIPLE XR50 / XR25 SERIES STAGES
TO BE STACKED IN AN X/Y CONFIGURATION

M6 X 1.0 TAPPED HOLE
7.0mm [0.28in] THREAD DEPTH
2 PLACES, INDICATED BY 'X'

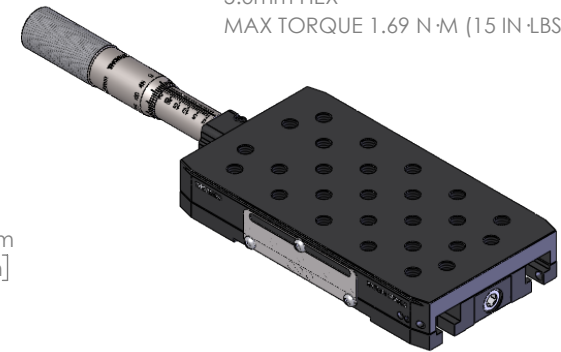
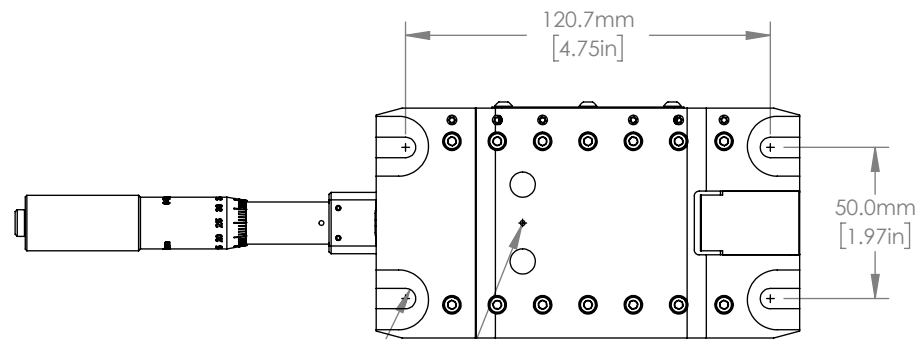
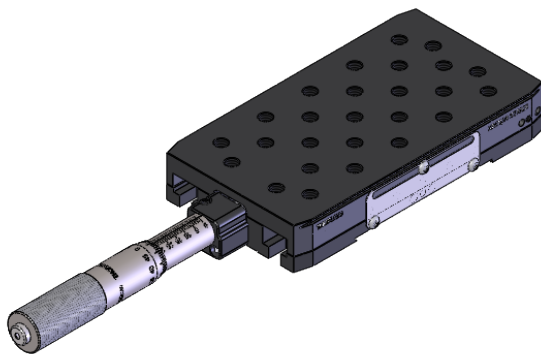
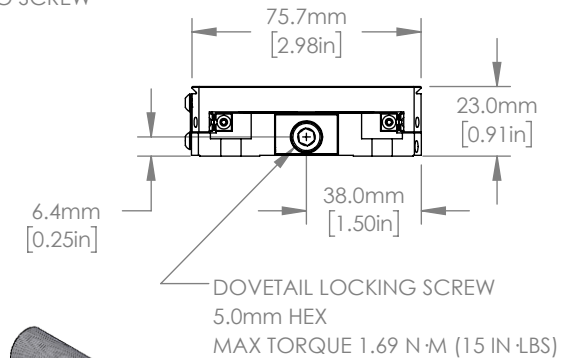
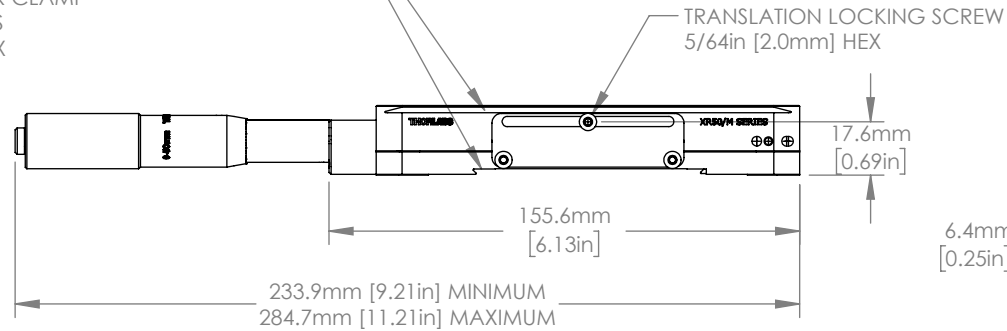
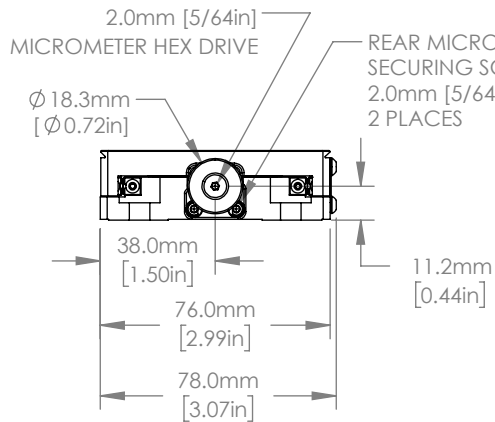

MOUNTING SLOT FOR USE WITH
M6 x 1.0 [1/4in-20] MOUNTING SCREWS
4 PLACES

METRIC IDENTIFICATION MARK

FOR INFORMATION ONLY
NOT FOR MANUFACTURING PURPOSES

DRAWING PROJECTION			THORLABS www.thorlabs.com	
NAME	DATE	METRIC 50mm CROSSED ROLLER TRANSLATION STAGE		
DRAWN	CS	25/JUL/17	REV B	
APPROVAL	HP	25/JUL/17	MATERIAL N/A	
COPYRIGHT © 2017 BY THORLABS			ITEM #	APPROX WEIGHT
VALUES IN PARENTHESIS ARE CALCULATED AND MAY CONTAIN ROUND OFF ERRORS			XR50C/M	0.70 kg