

INTEGRATED DOVETAIL CHANNELS  
ALLOW MULTIPLE XR50 / XR25 SERIES STAGES  
TO BE STACKED IN AN X/Y CONFIGURATION

1/4-20 TAPPED HOLE  
0.28 [7.0mm] THREAD DEPTH  
2 PLACES, INDICATED BY 'X'

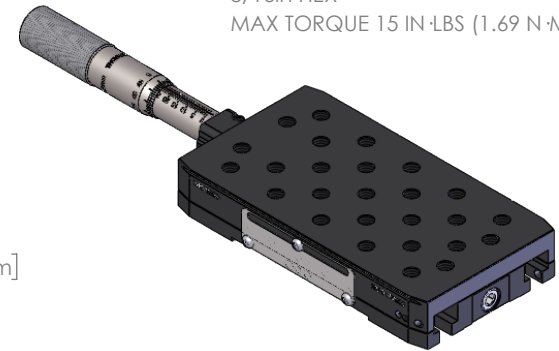
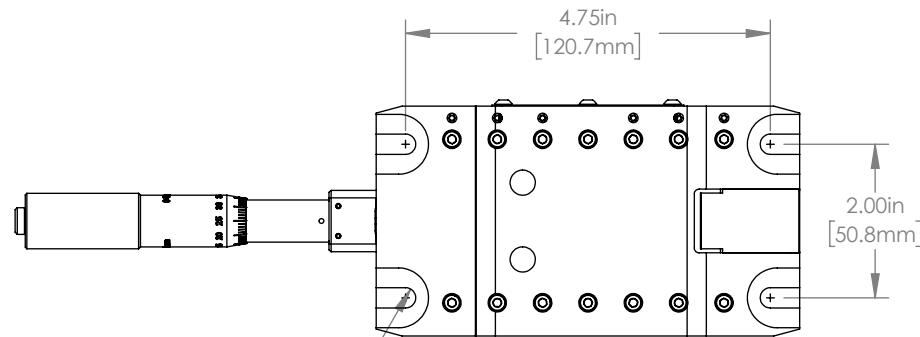
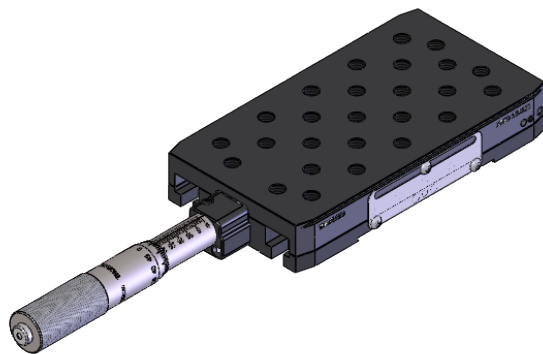
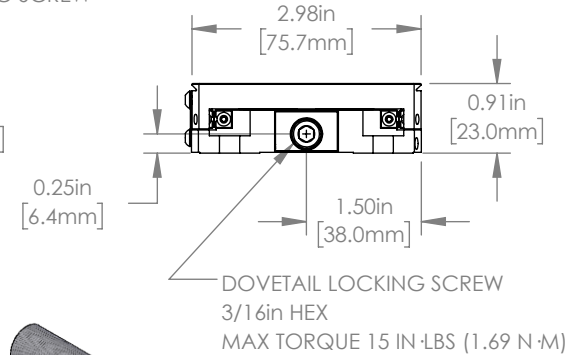
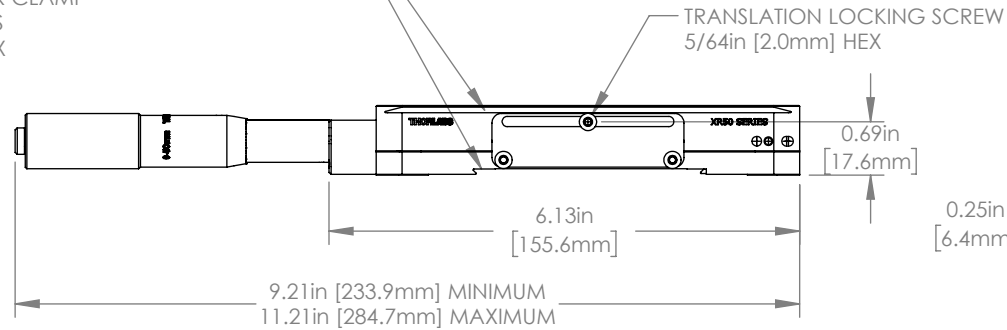
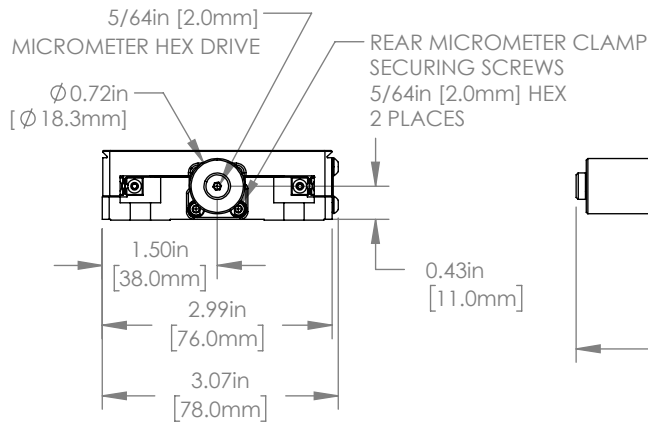

MOUNTING SLOT FOR USE WITH  
1/4-20 [M6 x 1.0] MOUNTING SCREWS  
4 PLACES

FOR INFORMATION ONLY  
NOT FOR MANUFACTURING PURPOSES

DRAWING PROJECTION



	NAME	DATE
DRAWN	CS	25/JUL/17
APPROVAL	HP	25/JUL/17

COPYRIGHT © 2017 BY THORLABS

VALUES IN PARENTHESIS ARE CALCULATED  
AND MAY CONTAIN ROUND OFF ERRORS

**THORLABS**  
www.thorlabs.com

50mm CROSSED ROLLER  
TRANSLATION STAGE

MATERIAL

N/A

REV  
B

ITEM #

XR50C

APPROX WEIGHT

0.70 kg