

COURSE ADJUSTMENT LOCKING SCREW

DIFFERENTIAL ADJUSTER (DM12)
 1.00in [25.4mm] TRAVEL
 COURSE ADJUSTMENT RESOLUTION
 0.02in [0.5mm] PER REV
 FINE ADJUSTMENT RANGE 0.01in [250µm]
 FINE ADJUSTMENT RESOLUTION:
 0.001in [25µm] PER REV
 (1) PER STAGE

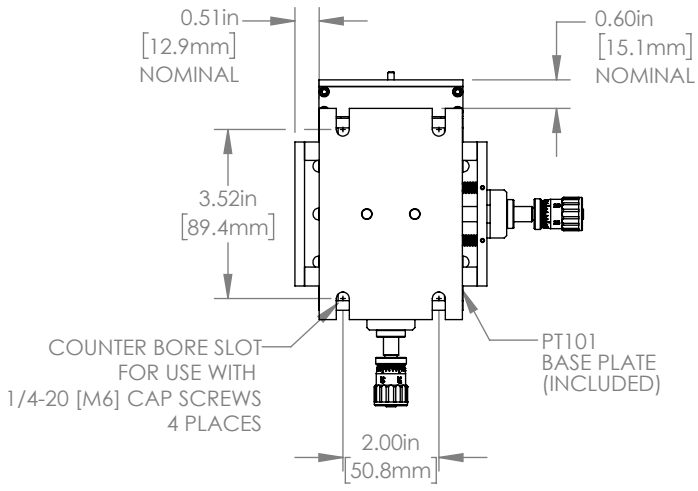
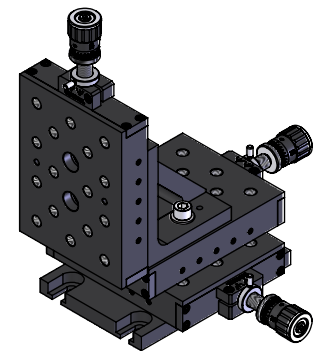
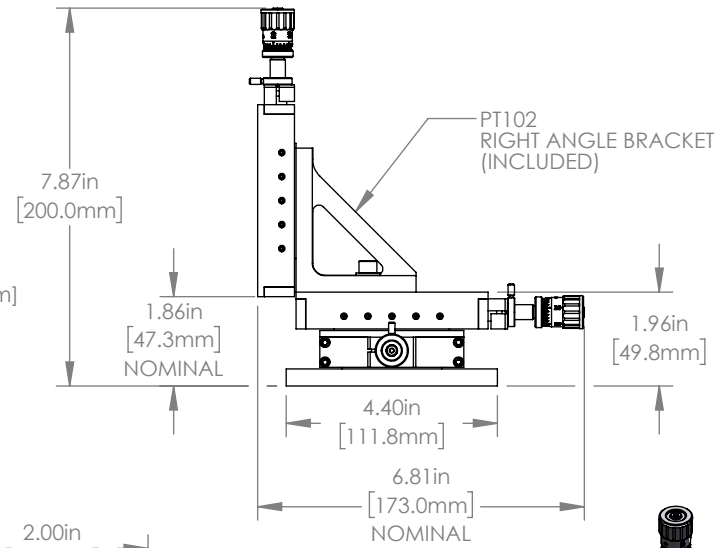

COUNTER BORE SLOT FOR USE WITH 1/4-20 [M6] CAP SCREWS 4 PLACES

PT101 BASE PLATE (INCLUDED)

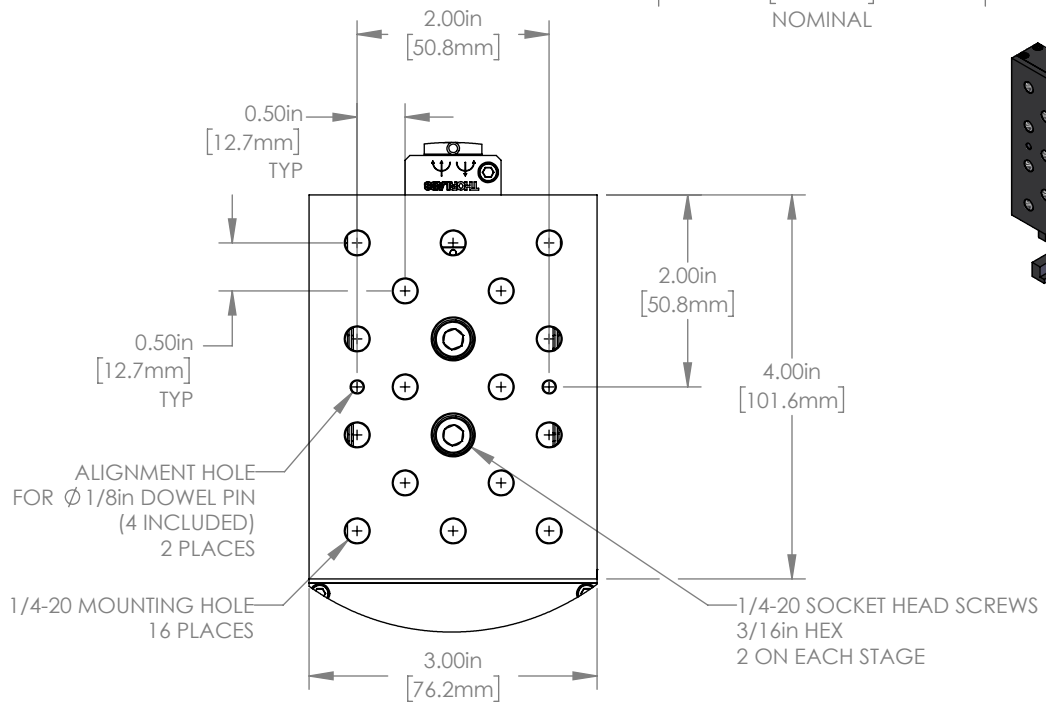

ALIGNMENT HOLE FOR Ø 1/8in DOWEL PIN (4 INCLUDED) 2 PLACES

1/4-20 MOUNTING HOLE 16 PLACES

DETAIL A

DRAWING PROJECTION		
NAME	DATE	
DRAWN AK	14/OCT/14	
APPROVAL TQ	14/OCT/14	
COPYRIGHT © 2014 BY THORLABS		
VALUES IN PARENTHESIS ARE CALCULATED AND MAY CONTAIN ROUND OFF ERRORS		

 www.thorlabs.com XYZ DIFFERENTIAL 1" TRANSLATION STAGE		MATERIAL	N/A	REV
				H
ITEM #	PT3A	APPROX WEIGHT	2.59 kg	

FOR INFORMATION ONLY
 NOT FOR MANUFACTURING PURPOSES