

MICROMETER HEAD:
150-811ST
1.00in TRAVEL
(1) PER STAGE

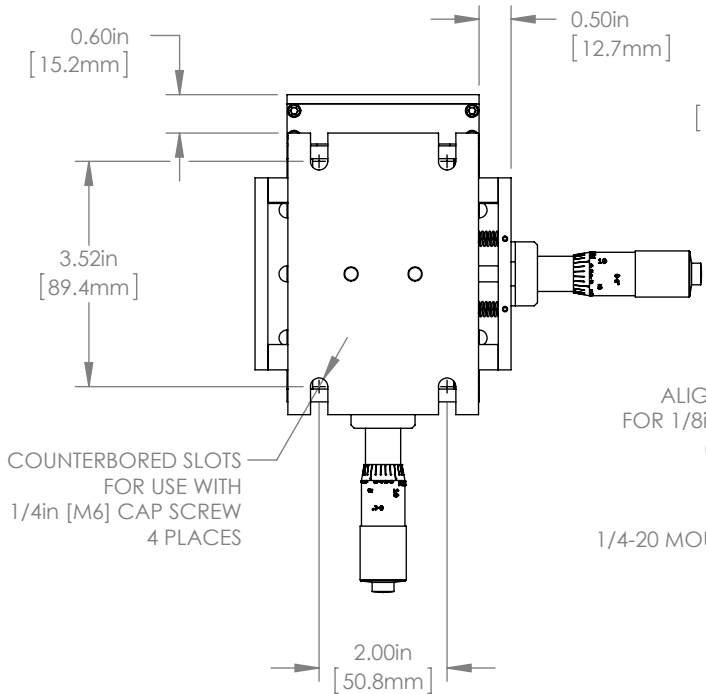

ALIGNMENT HOLE FOR 1/8in DOWEL PIN (4 INCLUDED) 2 PLACES
1/4-20 MOUNTING HOLE 16 PLACES

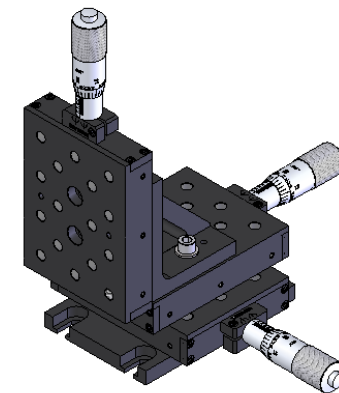
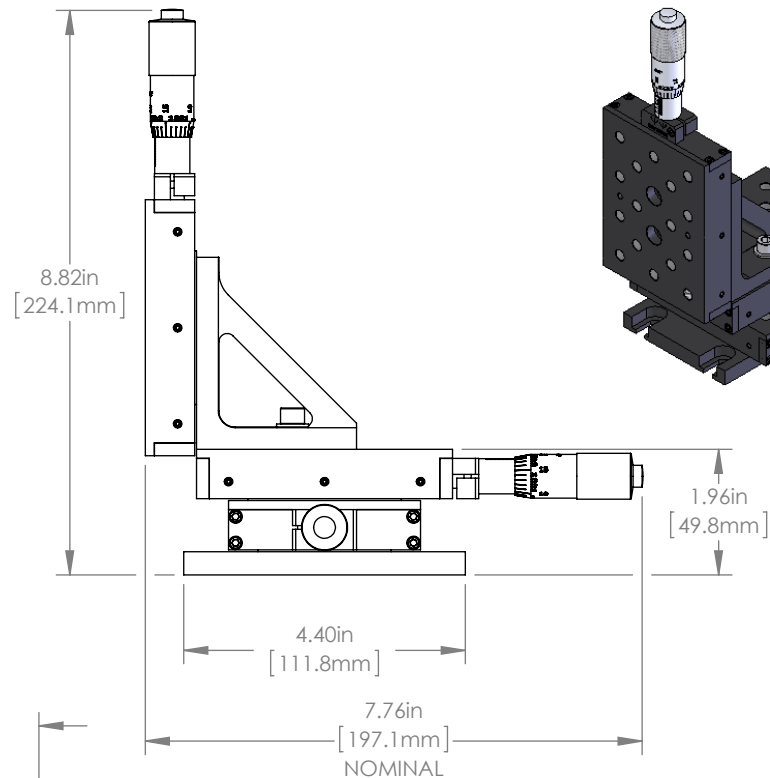
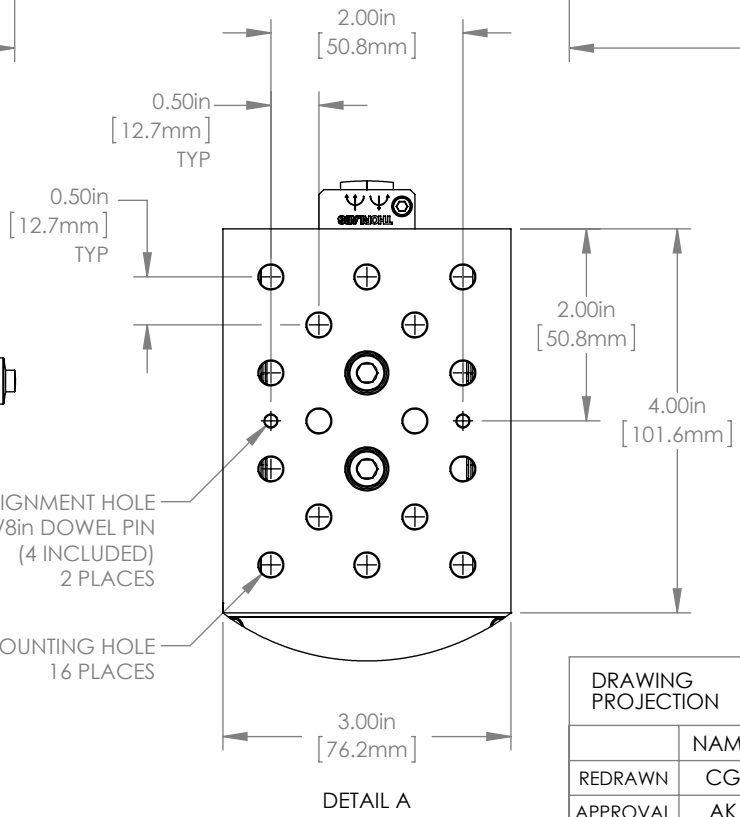

FOR INFORMATION ONLY
NOT FOR MANUFACTURING PURPOSES

DRAWING PROJECTION		
NAME	DATE	
REDRAWN CG	06/FEB/15	
APPROVAL AK	14/MAY/15	
COPYRIGHT © 2015 BY THORLABS		
VALUES IN PARENTHESIS ARE CALCULATED AND MAY CONTAIN ROUND OFF ERRORS		

THORLABS www.thorlabs.com	
XYZ 1.00in TRANSLATION STAGE	
MATERIAL	REV F
ITEM #	APPROX WEIGHT
PT3	2.71 kg