

INCLUDED BUT NOT SHOWN:

- 1.6FT (0.5m) CABLE

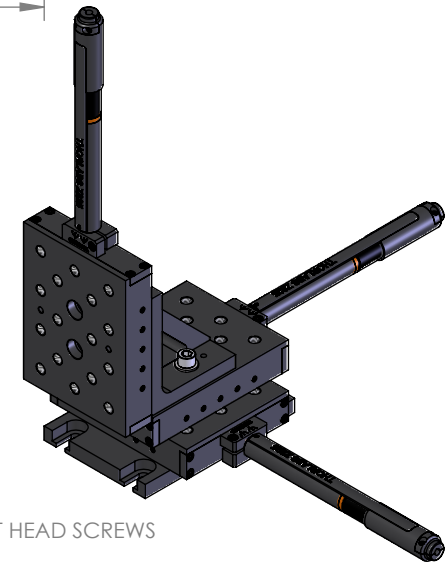
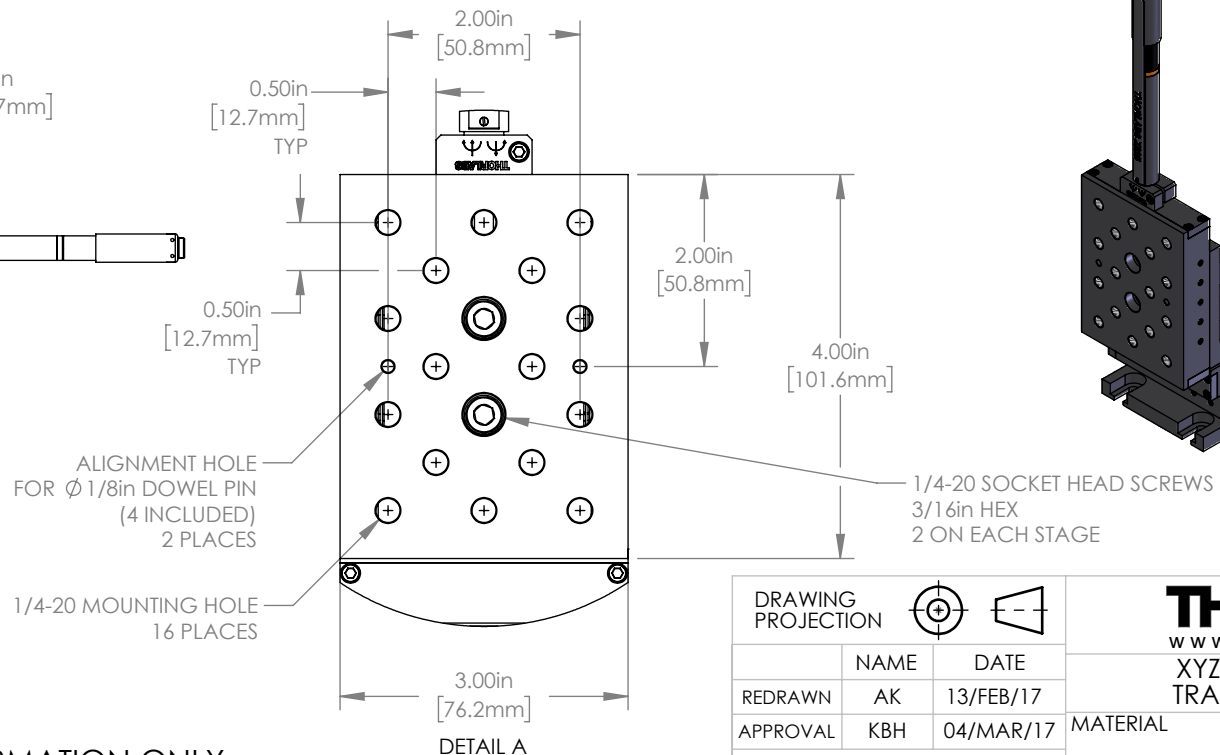
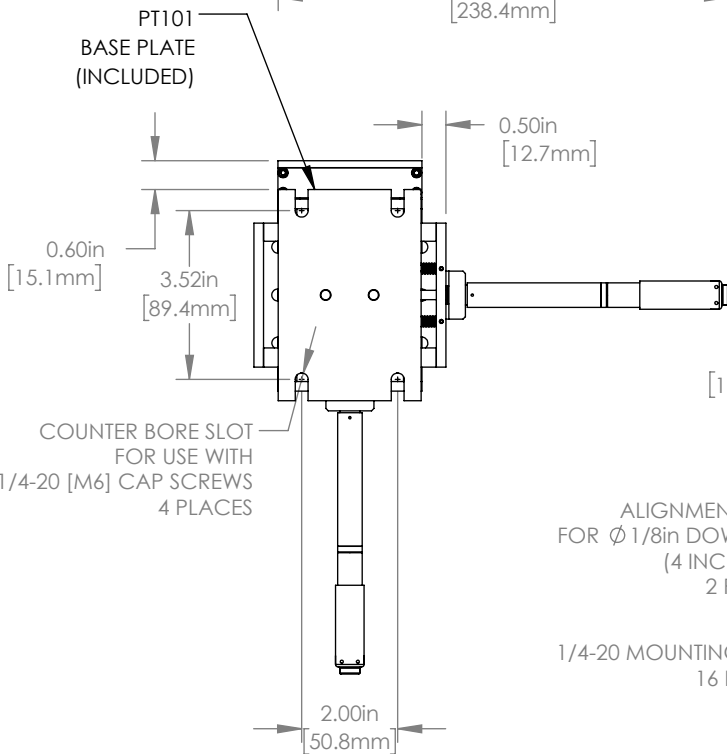
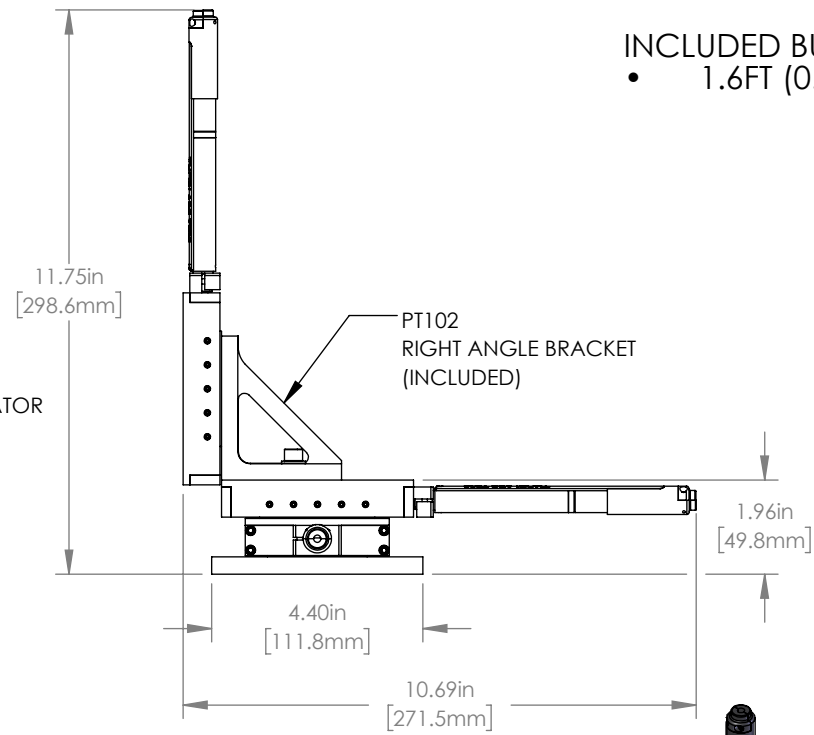
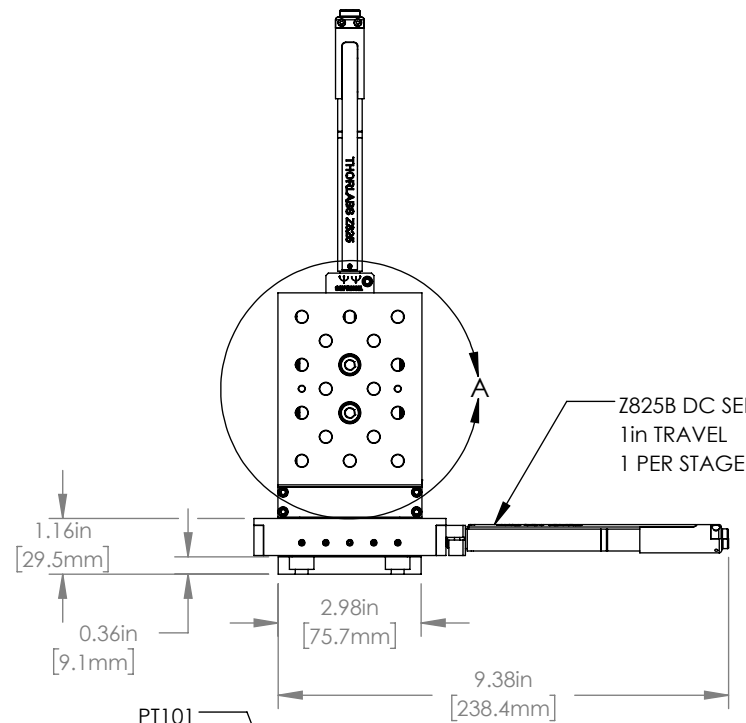

FOR INFORMATION ONLY
NOT FOR MANUFACTURING PURPOSES

DRAWING PROJECTION		
NAME	AK	DATE
REDRAWN	AK	13/FEB/17
APPROVAL	KBH	04/MAR/17
COPYRIGHT © 2017 BY THORLABS		
VALUES IN PARENTHESIS ARE CALCULATED AND MAY CONTAIN ROUND OFF ERRORS		

THORLABS www.thorlabs.com		MATERIAL	REV B
XYZ MOTORIZED 1in TRANSLATION STAGE			
ITEM #	N/A	APPROX WEIGHT	3.0 kg
PT3-Z8			