

TOP PLATE AT MAXIMUM TRANSLATION  
TOP PLATE IS SHOWN IN MID POSITION

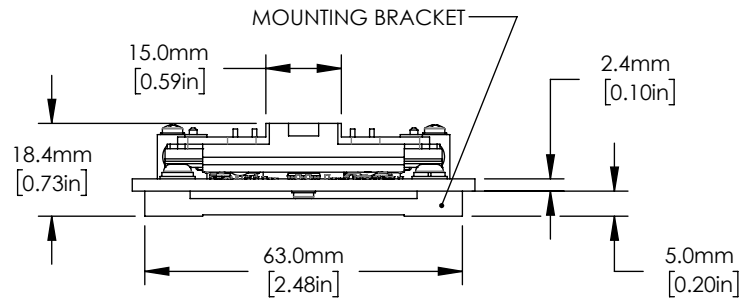

**LINEAR STAGE**

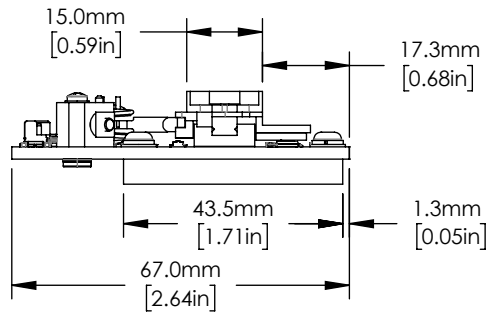
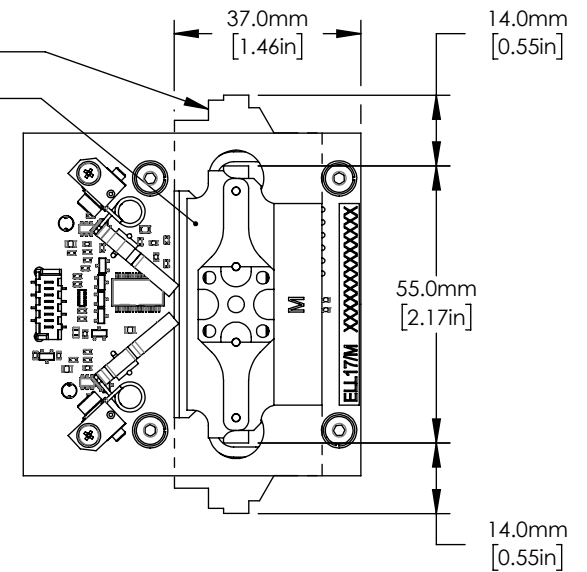
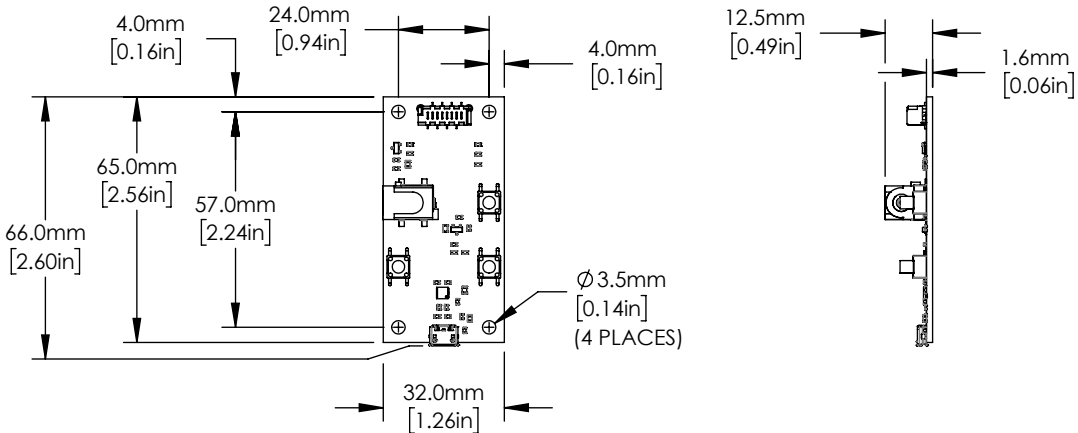
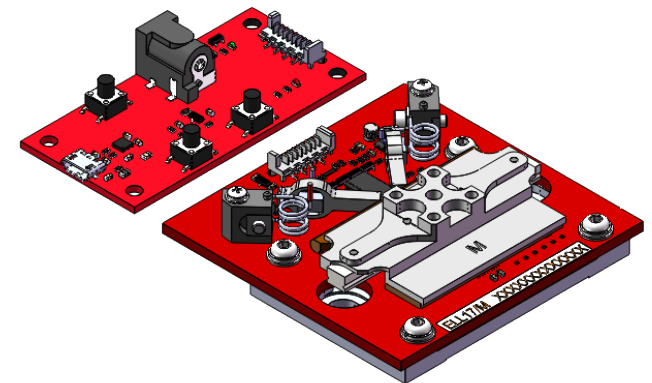

**DEMO BOARD**

FOR INFORMATION ONLY  
NOT FOR MANUFACTURING PURPOSES

DRAWING PROJECTION			<b>THORLABS</b> www.thorlabs.com	
NAME	DATE	28mm TRANSLATION STAGE KIT		
DRAWN	14/NOV/18	MATERIAL		REV
APPROVAL	14/NOV/18	N/A		A
COPYRIGHT © 2019 BY THORLABS			ITEM #	APPROX WEIGHT
VALUES IN PARENTHESIS ARE CALCULATED AND MAY CONTAIN ROUND OFF ERRORS			ELL17K/M	0.087 kg