



HILOBE®

The next generation of Roots pumps.

Intelligent, high-performance Roots pumps for low and medium vacuum applications.

The next generation of Roots pumps. Intelligent, high-performance Roots pumps for low and medium vacuum applications.

Perfectly adjustable

The Roots pumps in the innovative HiLobe series offer a broad range of pumping speeds and application possibilities. With their individually adjustable speeds, they can be perfectly matched to customer specifications. In general, Roots pumps need a backing pump adjusted to the gas flow which is suitable for the application in order to operate. Their flexible mounting position reduces installation costs.

High performance

The superior drive concept of the HiLobe pumps can shorten the pump-down times by about 20% compared to conventional Roots pumps, especially for rapid evacuations. The pumps are hermetically sealed to the atmosphere and provide a maximum integral leakage rate of $1 \cdot 10^{-6}$ Pa m³/s.

Low operating costs

The HiLobe series offers the lowest operating costs with the most uptime because only motors in efficiency class IE4 and optimized rotor geometries are used. Using purge gas is unnecessary in most cases due to the seal concept, which in turn lowers operating costs even more. The well-thought out air cooling concept also eliminates cost-intensive water cooling.

Intelligent

The intelligent interface technology of the HiLobe allows optimal adjustment and monitoring of processes. The intelligent condition monitoring also guarantees a long service life and top operating safety.

Applications



Electron beam welding



Leak detection



Metallurgy



Coating



Customer benefits



Freeze drying

- Pumping speed range, depending on version, from 520 – 2,100 m³/h because of variable rotation speed control
- Shortest pump-down times due to superior, next-generation drive concept
- Intelligent interface technology allows process adjustment and condition monitoring (Industry 4.0)
- Hermetically sealed pump with leak rate of $< 1 \cdot 10^{-6}$ Pa m³/s as dynamic seals to the outside are eliminated
- Low operating costs because of state-of-the-art air cooling up to +40 °C and motor technology (IE4 Standard)
- Long service life and top operating safety thanks to intelligent condition monitoring and innovative rotor/motor concept

The next generation of Roots pumps. Intelligent, high-performance Roots pumps for low and medium vacuum applications.

The innovative drive

The new, integrated and wear-free drive of the HiLobe series is hermetically sealed. The energy-efficiency-class IE4 motor also reduces operating costs.

Comparison of costs for maintenance and energy

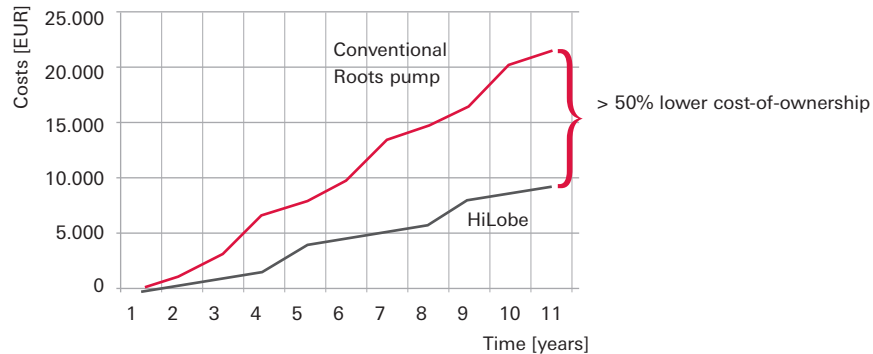

Flexible air cooling

The HiLobe's individual temperature control allows the air cooling to be flexibly controlled which guarantees optimal adjustment of the pump temperature for the processes.

Comparison of versions

	Integrated air cooling and frequency converter	Frequency converter and connection cable included in delivery	Low space requirements	Pumping speed
HiLobe 1001/1301/2101 (with housing)	■			up to 2100 m ³ /h
HiLobe 1002/1302 (without housing)		■	■	up to 1300 m ³ /h

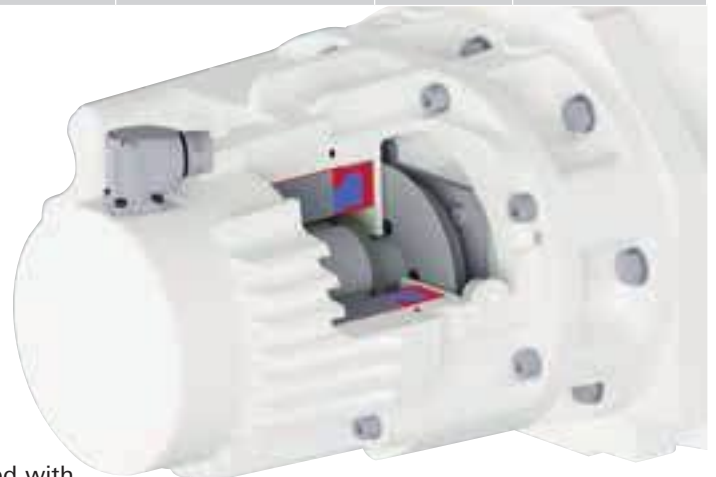

Hermetically sealed with integrated motor (IPM – internal permanent magnet)

Individual mounting options



HiLobe 1001H/1301H/2101H in horizontal mounting position, with integrated air cooling and frequency converter



HiLobe 1002/1302 without housing with convection cooling, separate frequency converter and connection cable

Dimensional drawing

HiLobe 1001/1301/2101:

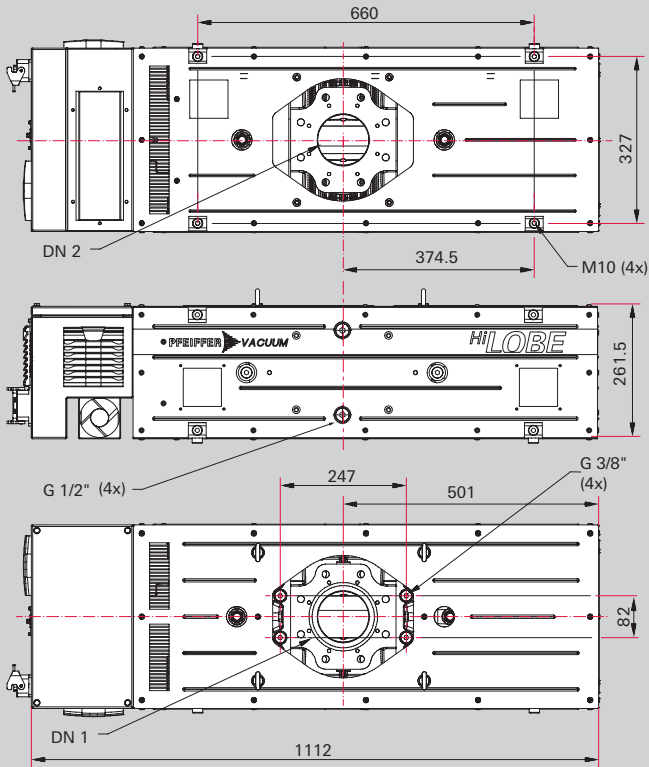

HiLobe 1002/1302:

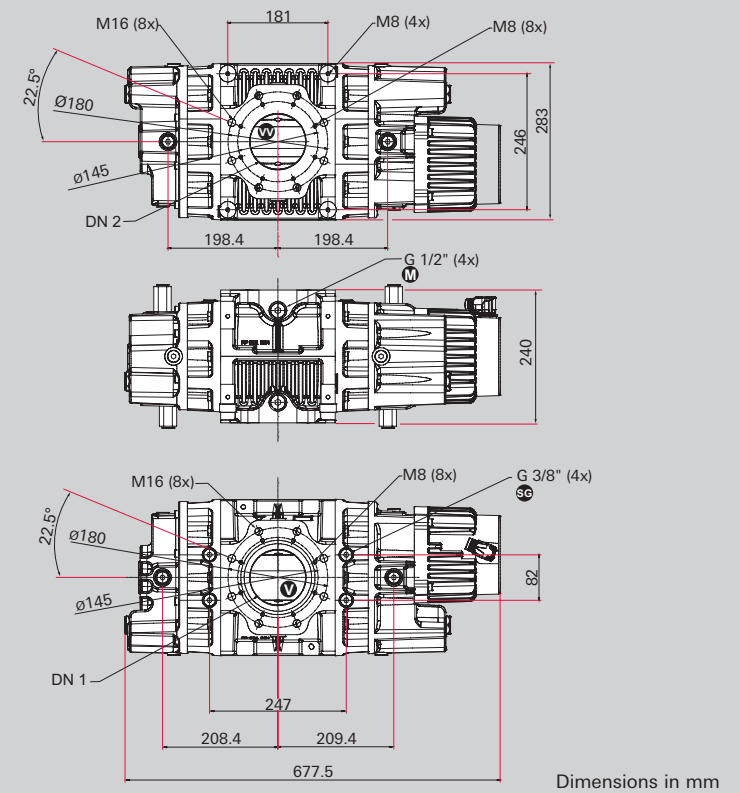

Pumping speed

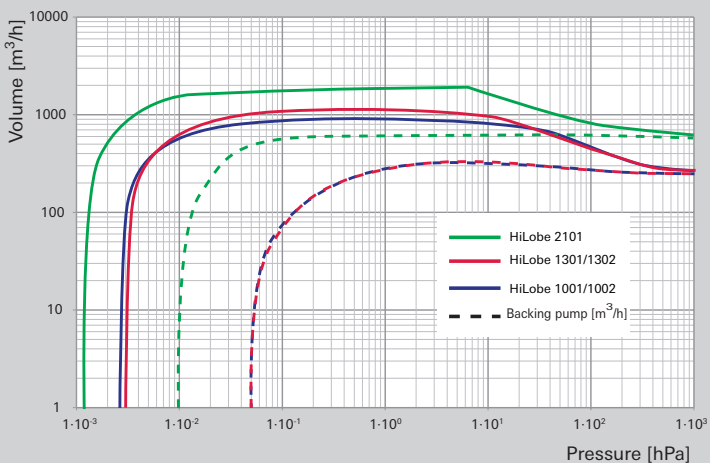

Pumping curves

for 400 l volumes, with Hepta 300 backing pump

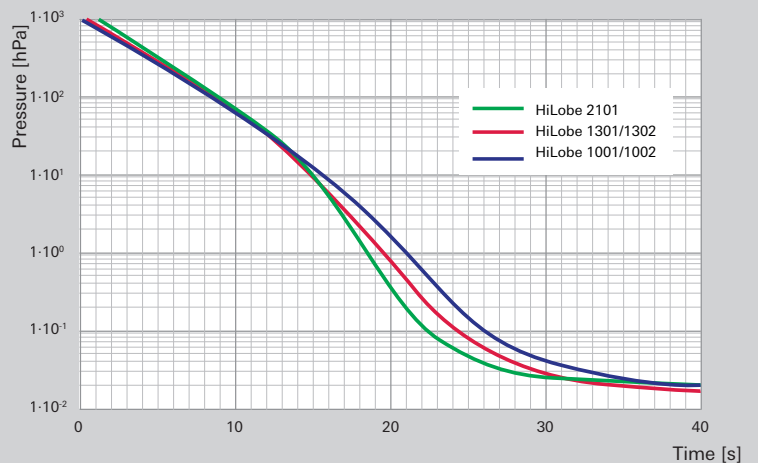

The next generation of Roots pumps.
Intelligent, high-performance Roots pumps for low and medium vacuum applications.

Technical data

	HiLobe 1001/H ¹⁾ HiLobe 1002/H ¹⁾	HiLobe 1301/H ¹⁾ HiLobe 1302/H ¹⁾	HiLobe 2101/H ¹⁾
Flange (in)	DN 100 ISO-F DN 100 PN 16		
Flange (out)	DN 100 ISO-F DN 100 PN 16		
Mounting orientation	0° (HV flange up) 90° (HV flange on the side)		
Cooling type, Standard	Active air cooling ²⁾		
Motor protection	PTC		
Max. differential pressure at maximum speed	62 hPa (21 hPa) ³⁾	57 hPa (13 hPa) ³⁾	20 hPa
Max. differential pressure at minimum speed	75 hPa (41 hPa) ³⁾		
I/O interfaces	RS-485, PV.can		
Rated pumping speed	520 – 1050 m ³ /h	520 – 1300 m ³ /h	520 – 2100 m ³ /h
Effective pumping speed	450 – 820 m ³ /h	450 – 990 m ³ /h	450 – 1450 m ³ /h
Rotational speed	3000 – 6000 rpm	3000 – 7500 rpm	3000 – 12000 rpm
Rotational speed in stand-by mode	1500 rpm		
Integral leak rate	1 · 10 ⁻⁶ Pa m ³ /s		
Emission sound pressure level (EN ISO 2151) at intake pressure 1 hPa and full rotational speed	65 dB(A)	70 dB(A)	75 dB(A)
Operating voltage	320–500 AC, 50/60 Hz		
Nominal power at maximum speed	2 kW	2.5 kW	3.5 kW
Operating fluids	P3, mineral oil		
Operating fluid quantity	0.65 l		
Dimensions (L x W x H)	1112 x 328 x 260 mm (678 x 282 x 240 mm) ³⁾		
Protection class	IP 54		
Ambient temperature	5 – 40 °C		
Weight	150 kg (105 kg) ³⁾		

¹⁾ Horizontal direction of flow

²⁾ Applicable for HiLobe 1001/1301/2101 only: Integrated air cooling in housing with built-in frequency converter

³⁾ Values in parenthesis = HiLobe 1002/1302: Convection cooling without housing with separate frequency converter and connecting cables

Direction of flow		a
Vertical		2
Horizontal		3

Size		b
HiLobe 100X		0
HiLobe 130X		1
HiLobe 2101		2

Cooling ¹⁾		c
Active air cooling		1
Convection cooling		2

¹⁾ HiLobe 1001/1301/2101: Integrated air cooling in housing with built-in frequency converter;
HiLobe 1002/1302: Convection cooling without housing with separate frequency converter and connecting cables

Accessories

Accessories	Order number
Controller/cable	
HPU 001, Handheld Programming Unit	PM 051 510 -T
RJ 45 Interface Cable on M12	PM 051 726 -T
Accessories Package for HPU	PM 061 005 -T
USB RS-485 Converter	PM 061 207 -T
DCU 002, Display Control Unit	PM 061 348 -T
TCS 11, Adapter for TC 110/120	PM 061 636 -U
Temperature sensor, PT100, stainless steel, FPM seal	PP 100 090 -T
Components/seals	
Splinter shield, DN 100 ISO-F and DN 100 ISO-K	PP 030 149 AX
Splinter shield, DN 100 PN16	PP 042 350 -X
Bolt set, steel, zinc plated, DN 100 ISO-F	PP 042 645 -T
Bolt set, stainless steel, DN 100 ISO-F	PP 042 655 -T
Bolt set, steel, zinc-plated, DN 100 PN16	PP 042 663 -T
Claw set, stainless steel, DN 100 ISO-K	PP 042 660 -T
Claw set, steel, zinc-plated, DN 100 ISO-K	PP 042 661 -T
Claw set, steel, zinc plated, DN 100 ISO-K, for flange with sealing groove	PP 042 662 -T
Blank flange set, stainless steel, DN 100 ISO-F	PP 042 664 -T
Blank flange set, stainless steel, DN 100 ISO-K	PP 042 665 -T
Blank flange set, stainless steel, DN 100 PN16	PP 042 666 -T
Collar flange, stainless steel, DN 100 ISO-F	320FLU100
Collar flange, steel, zinc plated, DN 100 ISO-F	350FLU100
Centering ring with outer ring, aluminum/FPM, DN 100 ISO-F and DN 100 ISO-K	PF 303 110 -T
Set of seals, FPM, DN 100 PN16	PP 042 667 -T
Operating fluids	
P3, mineral oil, 0.5 l	PK 001 136 -T
P3, mineral oil, 1 l	PK 001 106 -T
P3, mineral oil, 5 l	PK 001 107 -T
P3, mineral oil, 20 l	PK 001 108 -T

VACUUM SOLUTIONS FROM A SINGLE SOURCE

Pfeiffer Vacuum stands for innovative and custom vacuum solutions worldwide, technological perfection, competent advice and reliable service.

COMPLETE RANGE OF PRODUCTS

From a single component to complex systems:

We are the only supplier of vacuum technology that provides a complete product portfolio.

COMPETENCE IN THEORY AND PRACTICE

Benefit from our know-how and our portfolio of training opportunities!

We support you with your plant layout and provide first-class on-site service worldwide.

Are you looking for a
perfect vacuum solution?
Please contact us:

Pfeiffer Vacuum GmbH
Headquarters - Germany
T +49 6441 802-0

www.pfeiffer-vacuum.com