



Z8 Series Motorized DC Servo Actuators

User Guide



Original Instructions

Contents

Chapter 1 Overview	1
1.1 Description	1
Chapter 2 Safety	2
2.1 Safety Information	2
2.2 General Warnings	3
Chapter 3 Connection Details & Specifications	4
3.1 Pin Assignments	4
3.2 Description of connections	5
Chapter 4 Operation and Maintenance	6
4.1 Compatible Drivers and Software	6
4.2 Maintenance	6
Chapter 5 Specifications	7
5.1 Specifications	7
5.2 How to Calculate the Linear Displacement per Encoder Count	8
5.3 Notes on Max Velocity and Acceleration/Deceleration Profile	8
Chapter 6 Regulatory	9
6.1 Declarations Of Conformity	9
6.1.1 For Customers in Europe	9
6.1.2 For Customers In The USA	9
6.2 Waste Electrical and Electronic Equipment (WEEE) Directive	9
6.2.1 Compliance	9
6.2.2 Waste treatment on your own responsibility	10
6.2.3 Ecological background	10
6.3 CE Declaration	11
Chapter 7 Thorlabs Worldwide Contacts	15

Chapter 1 Overview

1.1 Description

Thorlabs has developed this series of high-resolution motorized actuators for use in high precision applications. From drop-in replacements to custom mounts, these motorized actuators will satisfy even the most demanding requirements. Three different travel lengths are offered; 6.0 mm, 12.0 mm and 25.0 mm.

The Z812B and Z825B actuators are shipped with a clamping bush fitted, ready for use with a 3/8" barrel mount. The Z806 and Z812 actuators thread into a 1/4" -80 mounting bush.

The Z800 series Motorized Actuators use a 6V DC servomotor that provides sufficient torque for high load capabilities. Utilizing a 67:1 gear reduction head and a 512 counts per rev precision encoder gives a minimum resolution of 29 nm. The actuators allow very small step sizes over the entire travel range, delivering greater flexibility with negligible backlash and fine resolution. The DC servomotor allows for continuously variable speeds while the optical encoder allows closed loop operation. The actuators use integrated hard stops that automatically cut the power when they have reached their mechanical limits.

The Z800 series Motorized Actuators are light, compact, and extremely durable. They are ideal for use in mirror mounts, translation stages, microscopes, OEM applications, and a wide variety of other components that require higher precision than most standard drive mechanisms allow.



Fig. 1.1 Z8 Series Actuators

Chapter 2 Safety

2.1 Safety Information

For the continuing safety of the operators of this equipment, and the protection of the equipment itself, the operator should take note of the **Warnings, Cautions** and **Notes** throughout this handbook and, where visible, on the product itself.

The following safety symbols may be used throughout the handbook and on the equipment itself.



Warning: Risk of Electrical Shock

Given when there is a risk of injury from electrical shock.



Warning

Given when there is a risk of injury to users.



Caution

Given when there is a risk of damage to the product.

Note

Clarification of an instruction or additional information.

2.2 General Warnings



Warning

To avoid injury never put anything in the gap between the Actuator and any rigid structure.



Caution

If the actuator encounters a hard stop while still in the middle of its range (i.e. a translation stage at the end of its travel range), the motor should be stopped as soon as possible to prevent damage to the gear head or motor and to keep the unit from overheating.

When the Z8 motors are fitted to certain optomech products e.g. the GNL series Goniometers, it is possible that the motor will reach the mechanical hardstops of the stage before the motor limit switches are activated. In this case, DO NOT continue to drive the motor into the hardstop as this will damage the motor. As a guide, the total current drawn should not exceed 80 mA.



Caution

The control PC used to operate the driver for the Z8 series actuators must be running APT Software version 2.8.0 or higher.

Earlier versions of software do not support this product.



Caution

When storing these units, be sure to fully retract the lead screw to protect the threads from damage. Improper connection of the motor will result in permanent damage. All power supplied to the motor should be turned off before altering any connections to the motor. Check all connections before supplying power to the motor.

Chapter 3 Connection Details & Specifications

3.1 Pin Assignments

Pin assignments for the D-Type connector on the motor flying lead are described below..

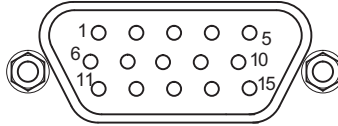

Fig. 3.1 Output Connector

Pin	Description	Pin	Description
1	Ground (Limit and Vcc)	9	Ident Resistor
2	Forward Limit	10	Vcc (+5 V DC)
3	Reverse Limit	11	Encoder Ch A
4	Reserved for Future Use	12	Reserved for Future Use
5	Motor (-)	13	Encoder Ch B
6	Reserved for Future Use	14	Reserved for Future Use
7	Motor (+)	15	Reserved for Future Use
8	Reserved for Future Use		



Caution

DO NOT connect a motor actuator while the K-Cube is powered up.

3.2 Description of connections

Motor (+): supplies a + VDC supply to the motor of the actuator. The maximum current is 240 mA.

Vcc: a connection should be made to a +5 VDC supply to power both channels A and B on the encoder.

Encoder Channels A and B: The Z800 series actuators use a Hall Effect encoder. Both channels A and B are supplied by the Vcc (5 V DC) connection.

GND: the ground connection for the encoder.

Motor (-): supplies a - VDC supply to the motor of the actuator. The maximum current is 240 mA.

Limit Ground: a common ground for both the forward and reverse limit switches.

Reverse Limit: the reverse limit prevents over driving of the actuator at its minimum extension.

Forward Limit: the forward limit prevents over driving of the actuator at its full extension.

Note. When a limit switch is activated, the switch makes contact, and the associated output line is connected to ground (pin 1).

When using a third party controller, the inputs must be connected via a 10 k pull up resistor as shown below. When either switch operates, the associated input is pulled to ground and the TTL buffers switch.

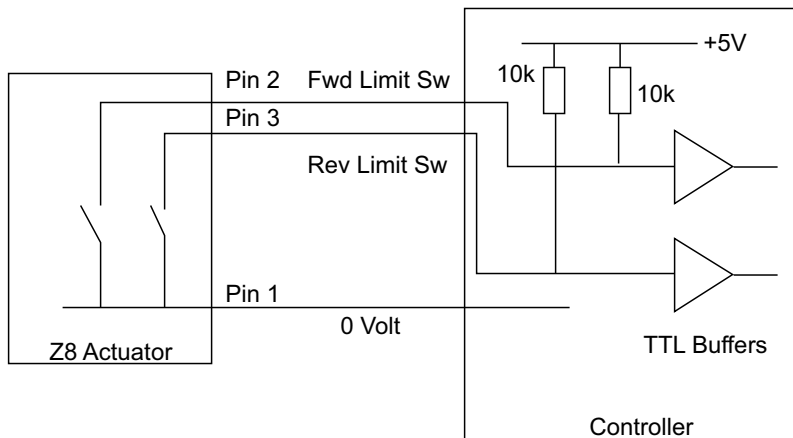

Fig. 3.2 Z8 Limit Switch Circuit

Chapter 4 Operation and Maintenance

4.1 Compatible Drivers and Software

The Thorlabs compatible controller for this product is the K-Cube Single Channel DC Servo Controller KDC101. The use of these controllers ensures optimal performance. All above performance specifications are guaranteed only with use of Thorlabs controllers and drivers.

4.2 Maintenance

Periodic greasing of the lead screw is advised, particularly in applications with a high duty cycle. Grease the lead screw thread as follows whenever the thread appears dry or the motor is noisy:

- 1) Drive the motor to extend the leadscrew to its full extent.
- 2) Apply a thin bead of high load, silicon free lubricant (e.g. Apiezon 100) as shown below.



Fig. 4.1 Greasing the Leadscrew

- 3) Drive the motor to retract the lead screw and distribute the grease.
- 4) Remove excess grease using a lint free cloth.

Chapter 5 Specifications

5.1 Specifications

Specification	Z806	Z812/Z812B	Z825B
Travel Range	6 mm	12 mm	25 mm
Gear Reduction	67:1		
Lead Screw Pitch	1.0 mm		
Feedback	Motor-mounted rotary encoder 512 counts/rev of the motor 34,304 counts/rev of leadscrew		
Limit Switches	Electromechanical		
Motor Type†	6 V DC Servo		
Backlash	<8 µm		
Axial Load Capacity	9.0 kg		
Speed Range*	50 µm/sec to 2.6 mm/sec		
Calculated Resolution‡	29 nm		
Phase to Phase Resistance	33.0 Ω		
Phase to Phase Inductance	0.6 mH		
Operating Temperature	41° to 104° F (5° to 40° C)		
Cable Length	1.6 ft (0.5 m)		
Connector	HDDB15		
Compatible Controller	KDC101 K-Cube DC Servo Controller		

† Although the motor drive voltage is nominally 6V, voltages up to 12V can be used with PWM controlled outputs.

* At 2.6 mm/sec, velocity ripple and distortion of the acceleration/deceleration profile may occur. For improved control, the max velocity should be limited to 2.3 mm/sec.

‡ Calculated Resolution. Actual resolution will depend on the applied load.

5.2 How to Calculate the Linear Displacement per Encoder Count

For the Z806, there are 512 encoder counts per revolution of the motor. The output shaft of the motor goes into a 67:1 planetary gear head. This requires the motor to rotate 67 times to rotate the 1.0 mm pitch lead screw one revolution. The end result is the lead screw advances by 1.0 mm.

To calculate the linear displacement of the actuator per encoder count:

$$512 \times 67 = 34,304 \text{ encoder counts per revolution of the lead screw}$$

Linear displacement of the lead screw per encoder count is:

$$1.0 \text{ mm} / 34,304 \text{ counts} = 2.9 \times 10^{-5} \text{ mm (29 nm)}$$

5.3 Notes on Max Velocity and Acceleration/Deceleration Profile

Although the max velocity is quoted at 2.6 mm/sec, it is possible to drive the Z8 motor at speeds in excess of this figure. However, at higher velocities the controlled acceleration and deceleration profiles may be affected. If these controlled profiles are required, then the speed should be reduced to around 2.3 mm/s maximum.

Furthermore, the velocity ripple due to the PID loop in the KDC101 driver is greater when the unit is running at the higher velocities.

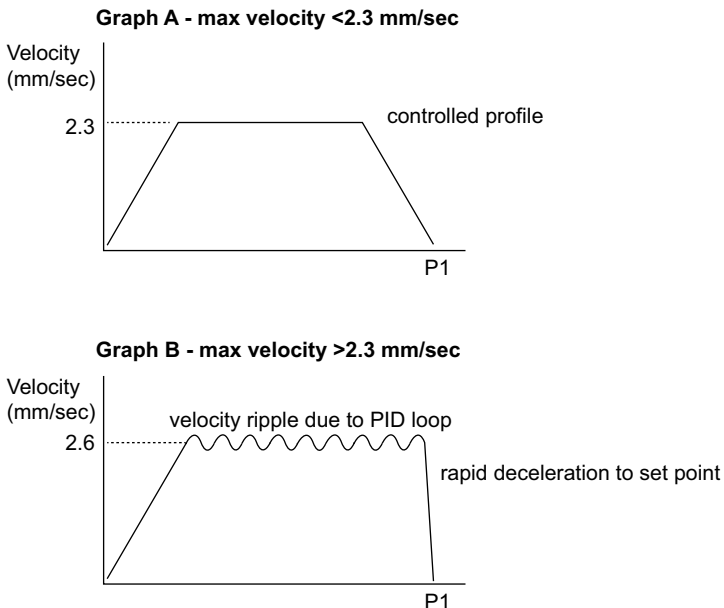

Fig. 5.1 Effects of Higher Velocity on Acceleration/Deceleration Profile

Chapter 6 Regulatory

6.1 Declarations Of Conformity

6.1.1 For Customers in Europe

See Section 6.3.

6.1.2 For Customers In The USA

This equipment has been tested and found to comply with the limits for a Class A digital device, pursuant to part 15 of the FCC rules. These limits are designed to provide reasonable protection against harmful interference when the equipment is operated in a commercial environment. This equipment generates, uses and can radiate radio frequency energy and, if not installed and used in accordance with the instruction manual, may cause harmful interference to radio communications. Operation of this equipment in a residential area is likely to cause harmful interference in which case the user will be required to correct the interference at his own expense.

Changes or modifications not expressly approved by the company could void the user's authority to operate the equipment.

6.2 Waste Electrical and Electronic Equipment (WEEE) Directive

6.2.1 Compliance

As required by the Waste Electrical and Electronic Equipment (WEEE) Directive of the European Community and the corresponding national laws, we offer all end users in the EC the possibility to return "end of life" units without incurring disposal charges.

This offer is valid for electrical and electronic equipment

- sold after August 13th 2005
- marked correspondingly with the crossed out "wheelie bin" logo (see Fig. 1)
- sold to a company or institute within the EC
- currently owned by a company or institute within the EC
- still complete, not disassembled and not contaminated



Fig. 6.1 Crossed out "wheelie bin" symbol

As the WEEE directive applies to self contained operational electrical and electronic products, this "end of life" take back service does not refer to other products, such as

- pure OEM products, that means assemblies to be built into a unit by the user (e. g. OEM laser driver cards)
- components
- mechanics and optics
- left over parts of units disassembled by the user (PCB's, housings etc.).

If you wish to return a unit for waste recovery, please contact Thorlabs or your nearest dealer for further information.

6.2.2 Waste treatment on your own responsibility



If you do not return an "end of life" unit to the company, you must hand it to a company specialized in waste recovery. Do not dispose of the unit in a litter bin or at a public waste disposal site.

6.2.3 Ecological background

It is well known that WEEE pollutes the environment by releasing toxic products during decomposition. The aim of the European RoHS directive is to reduce the content of toxic substances in electronic products in the future.

The intent of the WEEE directive is to enforce the recycling of WEEE. A controlled recycling of end of life products will thereby avoid negative impacts on the environment

6.3 CE Declaration

		<h1>THORLABS</h1>	
		www.thorlabs.com	
<h2>EU Declaration of Conformity</h2> <p><i>in accordance with EN ISO 17050-1:2010</i></p>			
We:	Thorlabs Ltd.		
Of:	1 St. Thomas Place, Ely, CB7 4EX, United Kingdom		
in accordance with the following Directive(s):			
2006/42/EC	Machinery Directive (MD)		
2004/108/EC	Electromagnetic Compatibility (EMC) Directive		
2011/65/EU	Restriction of Use of Certain Hazardous Substances (RoHS)		
hereby declare that:			
Model:	Z8 Series		
Equipment:	6, 12 & 25mm Motorized Actuator		
is in conformity with the applicable requirements of the following documents:			
EN ISO 12100	Safety of Machinery. General Principles for Design. Risk Assessment and Risk Reduction		2010
EN 61326-1	Electrical Equipment for Measurement, Control and Laboratory Use - EMC Requirements		2013
and which, issued under the sole responsibility of Thorlabs, is in conformity with Directive 2011/65/EU of the European Parliament and of the Council of 8th June 2011 on the restriction of the use of certain hazardous substances in electrical and electronic equipment, for the reason stated below:			
does not contain substances in excess of the maximum concentration values tolerated by weight in homogenous materials as listed in Annex II of the Directive			
I hereby declare that the equipment named has been designed to comply with the relevant sections of the above referenced specifications, and complies with all applicable Essential Requirements of the Directives.			
Signed:		On:	23 November 2015
Name:	Keith Dhese		
Position:	General Manager		EDC - Z8 Series -2015-11-23
			

Chapter 7 Thorlabs Worldwide Contacts

For technical support or sales inquiries, please visit us at www.thorlabs.com/contact for our most up-to-date contact information.



USA, Canada, and South America

Thorlabs, Inc.
sales@thorlabs.com
techsupport@thorlabs.com

UK and Ireland

Thorlabs Ltd.
sales.uk@thorlabs.com
techsupport.uk@thorlabs.com

Europe

Thorlabs GmbH
europe@thorlabs.com

Scandinavia

Thorlabs Sweden AB
scandinavia@thorlabs.com

France

Thorlabs SAS
sales.fr@thorlabs.com

Brazil

Thorlabs Vendas de Fotônicos Ltda.
brasil@thorlabs.com

Japan

Thorlabs Japan, Inc.
sales@thorlabs.jp

China

Thorlabs China
chinasales@thorlabs.com

Thorlabs verifies our compliance with the WEEE (Waste Electrical and Electronic Equipment) directive of the European Community and the corresponding national laws. Accordingly, all end users in the EC may return "end of life" Annex I category electrical and electronic equipment sold after August 13, 2005 to Thorlabs, without incurring disposal charges. Eligible units are marked with the crossed out "wheelie bin" logo (see right), were sold to and are currently owned by a company or institute within the EC, and are not disassembled or contaminated. Contact Thorlabs for more information. Waste treatment is your own responsibility. "End of life" units must be returned to Thorlabs or handed to a company specializing in waste recovery. Do not dispose of the unit in a litter bin or at a public waste disposal site.



UNLEASHED



THORLABS
www.thorlabs.com
