

## E-836.03 Piezo Amplifier, OEM Module, 1 Channel, -30 to 130 V

The E-836.03 piezo amplifier is designed and intended for driving capacitive loads (e.g. piezo actuators).

The E-836.03 must be installed in a suitable case before start-up. Only authorized and qualified personnel must install, operate, maintain and clean the E-836.03.

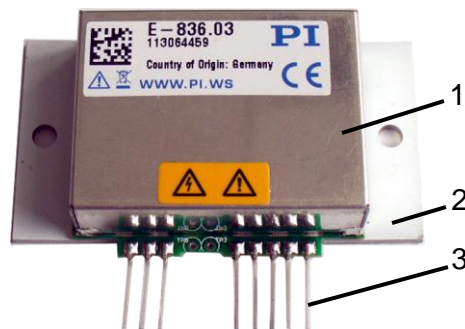

The E-836.03 piezo amplifier is a laboratory device as defined by DIN EN 61010-1.



### E-836.03 parts:

- 1 Cover
- 2 Bottom plate
- 3 Soldering pins

### Technical Data

	E-836.03
Function	Piezo amplifier module, 1 channel, OEM module
<b>Amplifier</b>	
Control input voltage	-2 to 12 V
Output voltage	-30 to 130 V
Peak current (<8 ms)	100 mA
Average current	50 mA
Current limitation	Short-circuit-proof
Voltage gain	10±0.1
Amplifier bandwidth, small signal (-3 dB, 5 V <sub>pp</sub> )	8 kHz (open)
Ripple, noise, 0 to 100 kHz	<0.8 mV <sub>rms</sub>
Capacitive base load (internal)	10 nF
Output impedance	5 Ω
Input impedance	0.5 MΩ
<b>Miscellaneous</b>	
Contacting	Soldering pins, Ø 0.7 mm, 9 mm ±0.5 mm
Overtemp protection	Deactivation at a case temperature of 85 °C
Dimensions	60 × 33 × 13 mm
Material	Metal shielded case
 Operating voltage	24 V --- ±10 %
 Dynamic power consumption	Max. 10 W

	<b>E-836.03</b>
<b>Ambient conditions and classifications</b>	
Area of application	For indoor use only
Maximum altitude	2000 m
Relative humidity	Highest relative humidity 80% for temperatures up to 31°C Decreasing linearly to 50% relative humidity at 40°C
Operating temperature range	5 to 50°C
Storage temperature range	0°C to 70°C
Transport temperature range	-25°C to +85°C
Overvoltage category	II
Protection class	I
Degree of pollution	2
Measurement category	I
Degree of protection according to IEC 60529	IP20

## Safety



### **Danger—Risk of Electric Shock**

If the E-836.03 is operated without a case, live parts will be accessible. Touching the live parts can result in serious injury or death. Electrical, magnetic and electromagnetic fields emitted by live parts can disturb the E-836.03 and/or the environment.

- Only operate the E-836.03 when it is installed in a shielded case that securely encloses all live parts and fulfills the requirements of electromagnetic compatibility.
- Since parts of the circuit will store charge, precautions must also be taken when the E-836.03 is not powered. After switching off the E-836.03, wait a minute before you touch parts of the E-836.03 to be sure that any residual voltage has dissipated.

If a protective earth conductor is not or not properly connected, dangerous touch voltages can occur on the E-836.03 in the case of malfunction or failure of the system. If touch voltages exist, touching the E-836.03 can result in serious injury or death from electric shock.

- Install the E-836.03 in a metal case that is connected to a protective earth conductor.
- Connect at least one of the GND pins of the E-836.03 to the case in which the E-836.03 is installed so that it is conductive (see p. 4).
- Make sure that the contact resistance is < 0.1 ohm at 25 A at all connection points relevant for the function of the protective earth conductor.
- Only operate the E-836.03 when a protective earth conductor is connected.
- If the protective earth conductor has to be temporarily removed (e.g. for modifications), reconnect the protective earth conductor before starting the E-836.03 up again.

### Notice—Risk of Damage to the E-836.03

The E-836.03 contains electrostatically sensitive equipment (ESD) and can be damaged if handled improperly.

- Avoid touching pins and PCB traces.
- Before you touch the E-836.03, discharge yourself of any electric charges:
  - Wear an antistatic wrist strap or
  - Before touching an electronic component, briefly touch a conducting, grounded object.
- Only handle and store the E-836.03 in environments that dissipate existing static charges to earth in a controlled way and prevent electrostatic charges (ESD workplace or electrostatically protected area, in short EPA).

Supply voltages that are too high or incorrectly connected can cause damage to the E-836.03. No limiting components are included.

- Do **not** exceed the supply voltage range for which the E-836.03 is specified (see “Operating voltage” in the Technical Data table on p. 1).
- Only operate the E-836.03 when the supply voltage is properly connected (for pin assignment, see p. 4).

### Dimensions

Dimensions in millimeters, decimal places separated by commas in drawings

#### Top view:

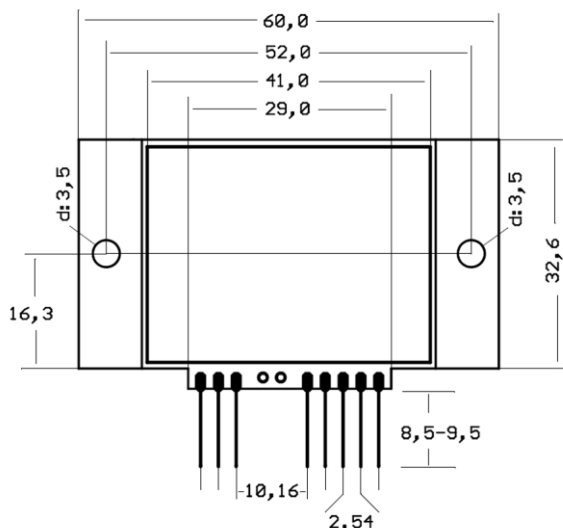

#### Side view:

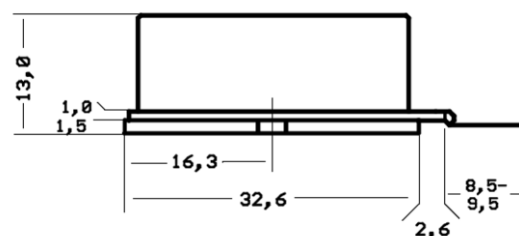

## Pin Assignment and Wiring

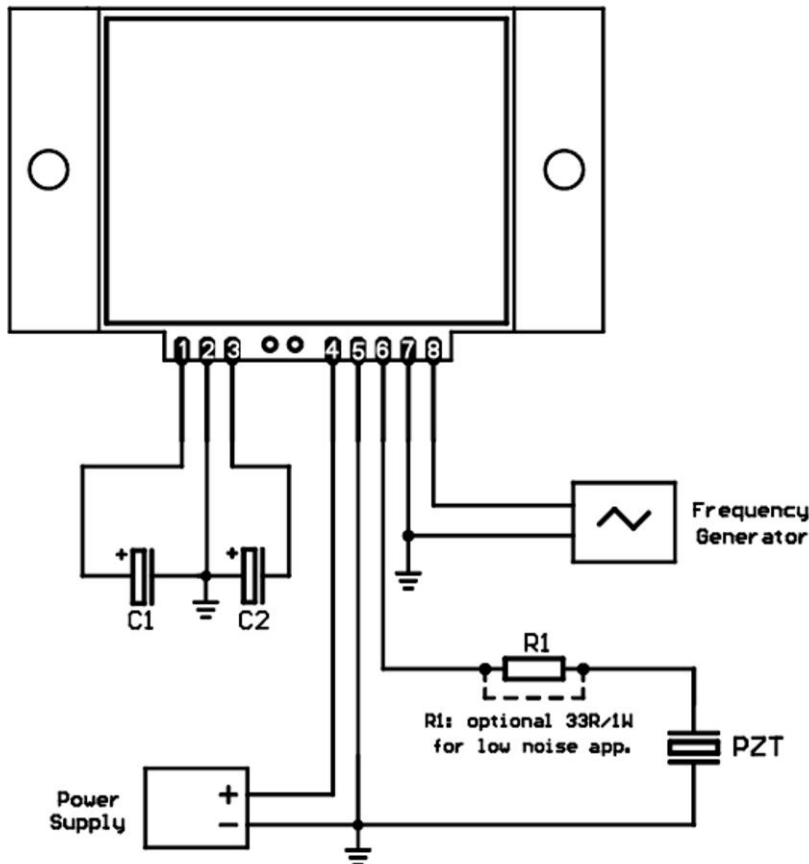

### Pin Description

- |   |  |
|---|--|
| 1 | +142 V output of internal DC/DC converter, see „Additional Capacitors“ below |
| 2 | GND, see „Additional Capacitors“ below                                       |
| 3 | -37 V output of internal DC/DC converter, see „Additional Capacitors“ below  |
| 4 | Supply voltage input: +24 V DC   |
| 5 | PGND   |
| 6 | High voltage output for piezo actuator („PZT“), -30 V to +130 V              |
| 7 | GND  |
| 8 | Control input (-2 to +12 V)*   |

\*The input voltage should always be in the range of -2 to +12 V. The range can be expanded to -3 to +13 V which results in an output voltage of -30 to +130 V. However, this can shorten the lifetime of the piezo actuator

### Protective Earth Conductor

Ensure the connection to a protective earth conductor:

1. Install the E-836.03 in a metal case that is connected to a protective earth conductor.
2. Connect at least one of the GND pins (2, 5 and 7) of the E-836.03 to the case in which the E-836.03 is installed so that it is conductive.

Note that the bottom plate of the E-836.03 is electrically insulated from the GND pins and the cover of the E-836.03.

### Additional Capacitors

For driving piezo loads  $\geq 1 \mu\text{F}$  with high dynamics, suitable capacitors C1 and C2 must be connected to pins 1, 2 and 3 of E-836.03 to avoid loss of performance. Dimension the capacitors as follows:

$$C1 = 10 \times C_{\text{piezo}}; \text{Elko } 160 \text{ V}$$

$$C2 = 10 \times C_{\text{piezo}}; \text{Elko } 50 \text{ V}$$

where

C1 and C2 are the capacitance values of the capacitors to be added

$C_{\text{piezo}}$  is the capacitance value of the piezo actuator.

Examples for typical piezo loads:

With a piezo load of  $1 \mu\text{F}$ , a capacitance value of  $10 \mu\text{F}$  is required for C1 and C2 each.

With a piezo load of  $4.7 \mu\text{F}$ , a capacitance value of  $47 \mu\text{F}$  is required for C1 and C2 each.

See the figure above for how to connect the capacitors.

## Cooling

E-836.03 can be used in static as well as dynamic applications. In the case temperature exceeds 85 °C (can be reached after a few minutes with maximum current and high output frequency), an internal sensor will shut down the output stage until the temperature is below 75 °C.

To avoid a shutdown of the output stage caused by overtemperature, you can affix a sufficiently dimensioned heat sink to the E-836.03. For an example see the figure below.

**E-836.03 with heat sink, side view:**

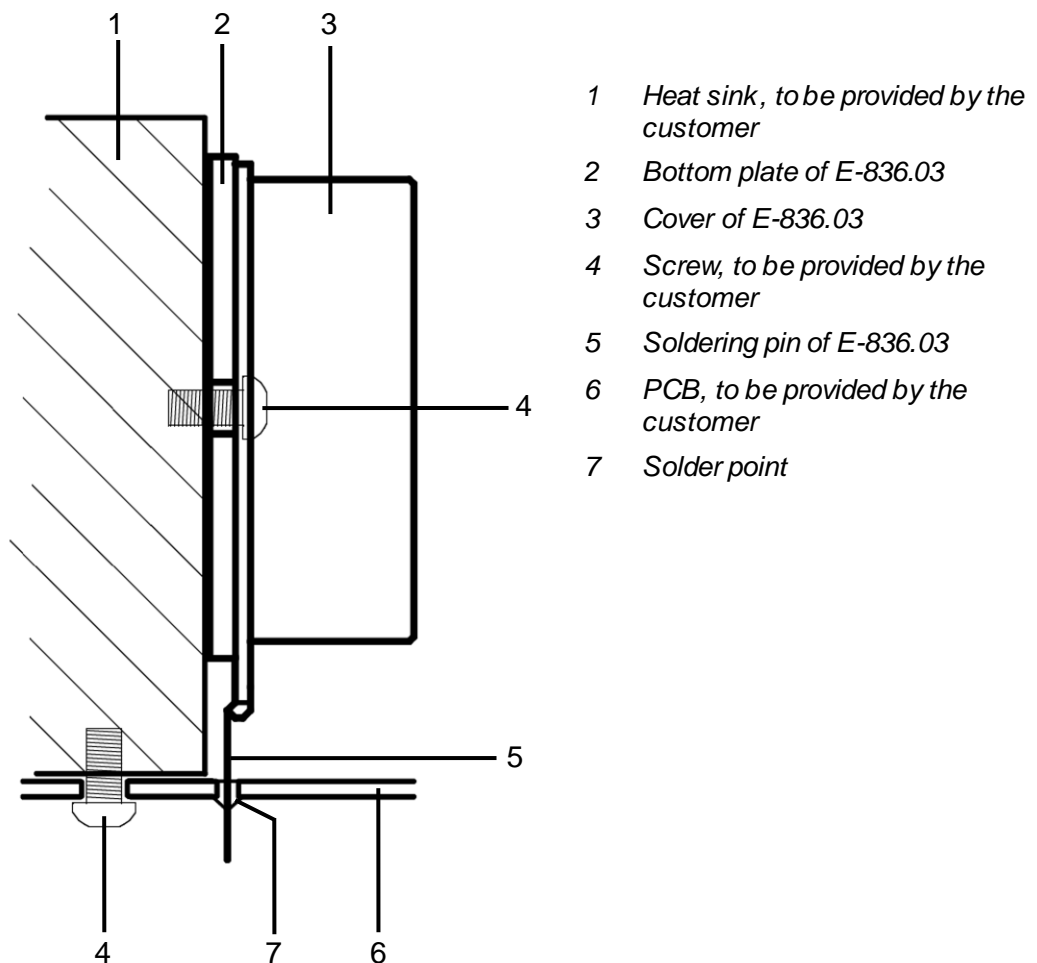

If you affix a heat sink, make sure that heat sink and bottom plate of the E-836.03 are connected to a protective earth conductor:

1. Connect the heat sink electrically conductive to the bottom plate of the E-836.03.
2. Connect the heat sink to a protective earth conductor (e.g. by connecting it to the case in which the E-836.03 is installed and which is connected to a protective earth conductor).

## Block Diagram

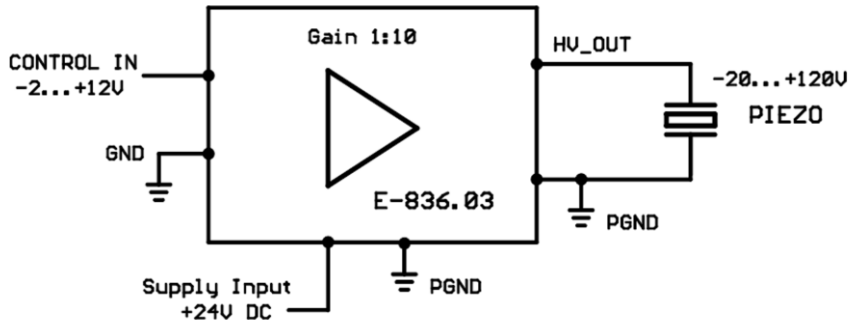

## Operation Notes

### Resolution of the Piezo Actuator

Naturally the switching frequency of the internal DC/DC converter of the E-836.03 will appear in the amplifier output, but at switching frequencies of 600 kHz, the piezo actuator is not able to follow, so that the resulting motion has much less noise than the driving voltage. This has to be considered if resolution is to be specified by measuring the piezo voltage. Especially with digital oscilloscopes, the measurement shows unrealistically high noise levels. For that reason, always measure the resulting motion with optical methods or other high-resolution, high bandwidth sensors.

### Limits of Operation

The following diagram shows the operating limits of the E-836.03 for various piezo loads. The curve values are capacitance values in  $\mu\text{F}$ .

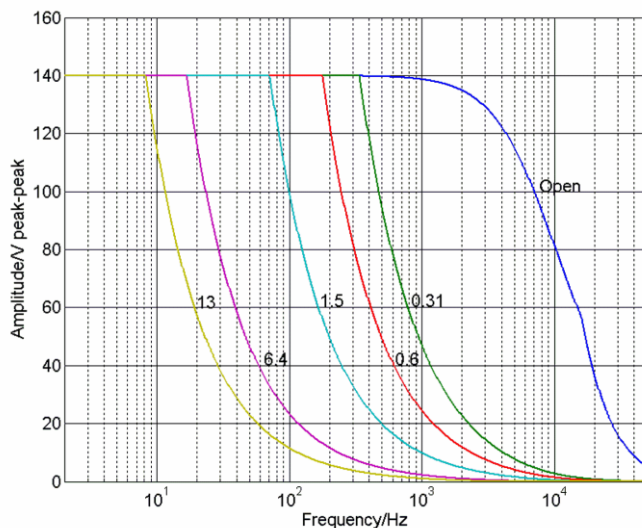

### Turn Off Behavior

During power-down, the E-836.03 generates a voltage pulse on the high-voltage output for the piezo actuator. A piezo actuator connected to the E-836.03 performs an appropriate motion which can cause a clicking sound. This behavior is harmless and does **not** affect the piezo actuator.