



**P7600 Series
TriMode™ Probes
Technical Reference**



077-0680-03



**P7600 Series
TriMode™ Probes
Technical Reference**

Copyright © Tektronix. All rights reserved. Licensed software products are owned by Tektronix or its subsidiaries or suppliers, and are protected by national copyright laws and international treaty provisions.

Tektronix products are covered by U.S. and foreign patents, issued and pending. Information in this publication supersedes that in all previously published material. Specifications and price change privileges reserved.

TEKTRONIX and TEK are registered trademarks of Tektronix, Inc.

TriMode is a trademark of Tektronix, Inc.

Velcro is a registered trademark of Velcro Industries B.V.

G3PO is a trademark of Corning Gilbert Inc.

Contacting Tektronix

Tektronix, Inc.
14150 SW Karl Braun Drive
P.O. Box 500
Beaverton, OR 97077
USA

For product information, sales, service, and technical support:

- In North America, call 1-800-833-9200.
- Worldwide, visit www.tek.com to find contacts in your area.

Warranty

Tektronix warrants that this product will be free from defects in materials and workmanship for a period of one (1) year from the date of shipment. If any such product proves defective during this warranty period, Tektronix, at its option, either will repair the defective product without charge for parts and labor, or will provide a replacement in exchange for the defective product. Parts, modules and replacement products used by Tektronix for warranty work may be new or reconditioned to like new performance. All replaced parts, modules and products become the property of Tektronix.

In order to obtain service under this warranty, Customer must notify Tektronix of the defect before the expiration of the warranty period and make suitable arrangements for the performance of service. Customer shall be responsible for packaging and shipping the defective product to the service center designated by Tektronix, with shipping charges prepaid. Tektronix shall pay for the return of the product to Customer if the shipment is to a location within the country in which the Tektronix service center is located. Customer shall be responsible for paying all shipping charges, duties, taxes, and any other charges for products returned to any other locations.

This warranty shall not apply to any defect, failure or damage caused by improper use or improper or inadequate maintenance and care. Tektronix shall not be obligated to furnish service under this warranty a) to repair damage resulting from attempts by personnel other than Tektronix representatives to install, repair or service the product; b) to repair damage resulting from improper use or connection to incompatible equipment; c) to repair any damage or malfunction caused by the use of non-Tektronix supplies; or d) to service a product that has been modified or integrated with other products when the effect of such modification or integration increases the time or difficulty of servicing the product.

THIS WARRANTY IS GIVEN BY TEKTRONIX WITH RESPECT TO THE PRODUCT IN LIEU OF ANY OTHER WARRANTIES, EXPRESS OR IMPLIED. TEKTRONIX AND ITS VENDORS DISCLAIM ANY IMPLIED WARRANTIES OF MERCHANTABILITY OR FITNESS FOR A PARTICULAR PURPOSE. TEKTRONIX' RESPONSIBILITY TO REPAIR OR REPLACE DEFECTIVE PRODUCTS IS THE SOLE AND EXCLUSIVE REMEDY PROVIDED TO THE CUSTOMER FOR BREACH OF THIS WARRANTY. TEKTRONIX AND ITS VENDORS WILL NOT BE LIABLE FOR ANY INDIRECT, SPECIAL, INCIDENTAL, OR CONSEQUENTIAL DAMAGES IRRESPECTIVE OF WHETHER TEKTRONIX OR THE VENDOR HAS ADVANCE NOTICE OF THE POSSIBILITY OF SUCH DAMAGES.

[W2 – 15AUG04]

Table of Contents

General safety summary	iv
Preface	vii
Theory of Operation.....	1
Introduction.....	1
TriMode Operation	6
Operating Voltages.....	8
Input Impedance and Probe Loading	14
Scale Factor	16
Probing Techniques to Maximize Measurement Fidelity	17
Reference	23
Single-Ended Measurements Using A and B Modes	23
Differential Measurements.....	24
Specifications	27
Warranted Characteristics.....	27
Typical Characteristics	29
Nominal Characteristics.....	34
User Service	35
Error Condition	35
Replaceable Parts	35
Preparation for Shipment	41
Index	

List of Figures

Figure 1: Adapters for the P7600 Series probes	3
Figure 2: Probe Tip Selection screen	4
Figure 3: TriMode input structure	7
Figure 4: Typical TriMode Probe Setup screen	7
Figure 5: Probe inputs	8
Figure 6: Operating voltage window	9
Figure 7: Dynamic range versus linearity	10
Figure 8: Termination voltage operating range	11
Figure 9: Probe Setup screen.....	12
Figure 10: TriMode probe coaxial input model.....	14
Figure 11: P76TA adapter simplified schematic	15
Figure 12: P76TA adapter and P75PST tip equivalent schematic.....	15
Figure 13: Preventing twist to the coaxial input cables	17
Figure 14: P75PST and P75TLRST TriMode Solder Tips.....	18
Figure 15: Solder ramp installed.....	18
Figure 16: Typical wire length from probe tip to circuit	20
Figure 17: P75TLRST solder tip with 0.010 in. of tip wire	21
Figure 18: P75TLRST solder tip with 0.050 in. of tip wire	21
Figure 19: P75TLRST solder tip with 0.100 in. of tip wire	22
Figure 20: P75TLRST solder tip with 0.200 in. of tip wire	22
Figure 21: Simplified model of a differential amplifier	24
Figure 22: Typical CMRR	25
Figure 23: Typical channel isolation	26
Figure 24: Typical rise time	31
Figure 25: Typical frequency response.....	31
Figure 26: Probe body and control box dimensions	32
Figure 27: P7600 Series Probe adapter dimensions	33
Figure 28: P75PST and P75TLRST solder tip dimensions	33
Figure 29: Removing the bullets.....	37
Figure 30: Installing the bullets.....	38

List of Tables

Table 1: Offset ranges.....	23
Table 2: Warranted electrical characteristics	27
Table 3: Warranted environmental characteristics	29
Table 4: Typical electrical characteristics.....	29
Table 5: Typical mechanical characteristics	30
Table 6: Nominal electrical characteristics	34
Table 7: Nominal adapter electrical characteristics.....	34
Table 8: TriMode probes replaceable parts	35
Table 9: Required equipment.....	35

General safety summary

Review the following safety precautions to avoid injury and prevent damage to this product or any products connected to it.

To avoid potential hazards, use this product only as specified.

Only qualified personnel should perform service procedures.

While using this product, you may need to access other parts of a larger system. Read the safety sections of the other component manuals for warnings and cautions related to operating the system.

To avoid fire or personal injury

Connect and disconnect properly. Connect the probe output to the measurement instrument before connecting the probe to the circuit under test. Connect the probe reference lead to the circuit under test before connecting the probe input. Disconnect the probe input and the probe reference lead from the circuit under test before disconnecting the probe from the measurement instrument.

Observe all terminal ratings. To avoid fire or shock hazard, observe all ratings and markings on the product. Consult the product manual for further ratings information before making connections to the product.

Do not apply a potential to any terminal, including the common terminal, that exceeds the maximum rating of that terminal.

Do not operate without covers. Do not operate this product with covers or panels removed.

Do not operate with suspected failures. If you suspect that there is damage to this product, have it inspected by qualified service personnel.

Avoid exposed circuitry. Do not touch exposed connections and components when power is present.

Do not operate in wet/damp conditions.

Do not operate in an explosive atmosphere.

Keep product surfaces clean and dry.

Terms in this manual These terms may appear in this manual:



WARNING. *Warning statements identify conditions or practices that could result in injury or loss of life.*



CAUTION. *Caution statements identify conditions or practices that could result in damage to this product or other property.*

Symbols and terms on the product

These terms may appear on the product:

- DANGER indicates an injury hazard immediately accessible as you read the marking.
- WARNING indicates an injury hazard not immediately accessible as you read the marking.
- CAUTION indicates a hazard to property including the product.

The following symbol(s) may appear on the product:



CAUTION
Refer to Manual

Preface

This manual discusses topics that are not covered in depth in the *P7600 Series TriMode Probes Quick Start User Manual*.

The main sections are:

- Theory of Operation — Contains probe details not covered in the user manual.
- Reference — Contains information about differential measurements and how to increase measurement accuracy.
- Specifications — Contains warranted, typical, and nominal characteristics for the probe, probe adapters and probe tip accessories.
- User Service — Describes troubleshooting and probe maintenance.

Theory of Operation

This section discusses operating considerations and probing techniques. For more detailed information about differential measurements and TriMode operation, refer to *Reference*. (See page 23.)

Introduction

The P7600 Series TriMode Probes are designed for use with DPO70000SX, MSO/DPO70000DX, and DPO/DSA70000D series oscilloscopes. These oscilloscope models feature an extended-bandwidth version of the TekConnect probe interface designed to support bandwidths up to 33 GHz. The P7600 Series probes contain probe-specific S-parameter data that, when transferred to the host oscilloscope after the initial connection is made, create unique system DSP filters.

The P7600 Series probes are optimized for high bandwidth; they are not general-purpose probes. The P7500 Series probe solder tips that can be used with the probes are miniaturized for electrical characteristics and access to dense circuitry, and must be handled carefully.

Probe Components

The probes are comprised of a control box, an active probe head, and an interconnect cable that transfers measured signals, power, and control signals between the control box and probe head. An optional adapter is required on the probe head to make the final connection to the DUT (device under test).

Control box. The probe control box assembly mates to the host instrument through an extended-bandwidth, 33 GHz TekConnect probe interface. The control box includes a membrane toggle switch to select the TriMode input mode:

- Differential (A–B)
- A input (single-ended to ground)
- B input (single-ended to ground)
- Common-mode (A+B/2 to ground)

The probe input mode can also be selected using the host oscilloscope Probe Control menu.

LEDs on the control box front and top panels indicate the selected input mode. Another LED on each panel indicates when an overload condition exists. Overloads are caused when parameters such as input voltages or termination voltage driver currents exceed the safe limits of the probe.

A mechanical latch and retention thumbscrew hold the probe securely to the instrument during use. The thumbscrew is only intended to be finger-tightened, and is machined to prevent tools from being used to over-torque it. To remove the probe, loosen the thumbscrew counterclockwise, depress the latch button to release the probe, and then pull out the probe.



CAUTION. *To prevent damage to the probe, use care when handling the probe. Rough or careless use can damage the probe.*

Interconnect cable. This cable consists of a low-loss coaxial signal cable that carries the acquired signal from the probe head to the control box. The cable also includes a 20-conductor bundle of wires that supply probe head power and control signals from the control box. Some of the wires carry bidirectional data, such as queries and responses about the type of probe adapter that is attached to the probe head, and other probe-specific information.

Probe head. The probe head is an active component that houses an amplifier and other support circuitry that precondition the acquired signals. It connects to the optional coaxial and solder tip adapters through a connector that, like the interconnect cable, carry signal, control and power signals.

The probe head is intended to be placed close to the DUT test point, within the final few inches (6 inches or less, for best performance), made with the optional coaxial and solder tip adapters.

Adapters. The P7600 Series probes require an optional TriMode adapter to complete the connection between the probe and your circuit. (See Figure 1 on page 3.) The adapters connect the probe to your circuit through 2.92 mm or SMP coaxial cables. For soldered, in-circuit connections, the connection is made through P7500 Series solder tips, such as the P75PST Performance Solder Tip.

There are several different coaxial tips available for the probes, which differ only in the tip connector type or the tip cabling. All of the coaxial tips provide a 50 ohm transmission line signal path from its input connector to the termination resistor at the probe amplifier input.

The adapter inputs are polarized, with the A input marked in red and the B input marked in black. All of the adapters are secured to the probe head with a 2 mm hex screw. Although the adapters can be “hot-plugged” (with the probe connected to the oscilloscope and powered on), the adapters should first be connected to the probe before the probe is connected to the instrument. This ensures a good power-on sequence for both the probe and attached adapter. After the probe is powered on with an attached adapter, data is transferred from the adapter, identifying it to the probe and oscilloscope.

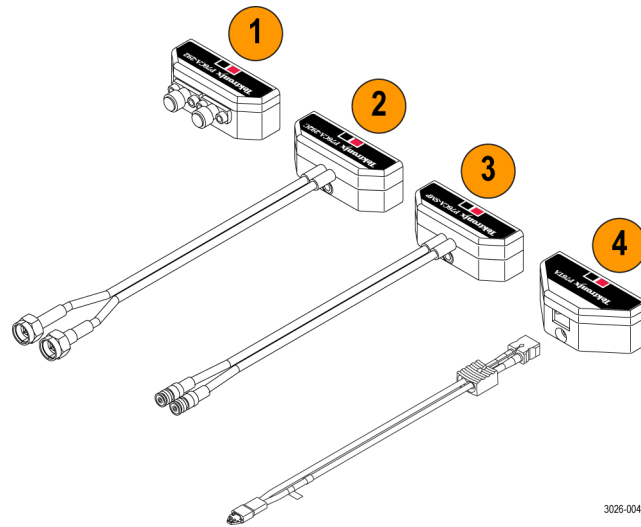

Figure 1: Adapters for the P7600 Series probes

1. P76CA-292: 2.92 mm Coax Adapter
2. P76CA-292C: 2.92 mm Coax Adapter with cables
3. P76CA-SMP: SMP Coax Adapter with cables
4. P76TA: P7500 TriMode Solder Tip Adapter (shown with P75PST Performance Solder Tip)

Use the P76CA-292 adapter with high bandwidth, low skew (<2 ps) cable pairs that have short (<6 in) lengths and high-quality male 2.92 mm connectors at the probe end. The other end of the cables can be customized with connectors that mate to your circuit.

P7500 Series solder tips. These tips are used with the P76TA adapter to make soldered connections to the DUT. You must manually choose the solder tip that you are using in the Probe Tip Selection screen. (See Figure 2.) This enables the correct DSP filtering to be used for your measurements. Maximum probe solder tip performance is only provided by the P75PST Performance Solder Tip.

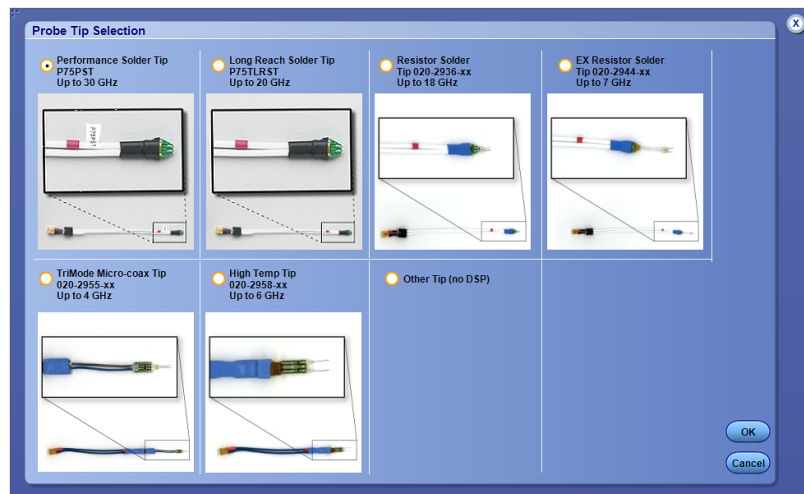

Figure 2: Probe Tip Selection screen

Probe Input Architecture

The input structure of the probe adapters differ between the coaxial and solder tip versions, and are discussed below.

Coaxial Adapters. When a P76CA-xxx coaxial adapter is attached to a P7600 Series probe, it provides a low VSWR, 50 ohm terminated input for taking TriMode differential signaling measurements. In order to provide low noise measurement performance, the coaxial adapters connect the input signal to the probe without attenuation, which results in a relatively low dynamic range limit. The P7600 Series probes have a quite large Offset Voltage and Termination Voltage adjustment range, however, which enables optimum placement of the probe dynamic range within the larger operating voltage window.

Low noise performance is also enhanced in the probe by the design of the probe amplifier, which features five step gain settings (0.25X/0.5X/1.0X/2.0X/4.0X). This step gain control enables lower noise performance by boosting the signal output amplitude at the more sensitive vertical channel scale factors. The optimum step gain setting is automatically selected by the host oscilloscope, based on the selected vertical channel scale factor.

Solder Tip Adapter. When a P76TA solder tip adapter and P75PST solder tip are attached to the probe, it provides a passive attenuation of the input signal to the probe. This passive attenuation network forms a Z0 probe input structure, which is enhanced by the adjustable termination voltage capability of the probe. For the common use case of probing a doubly-terminated 50 ohm transmission line, this results in a 5X broadband attenuation and a 225 ohm loading. (See Figure 12 on page 15.) The signal loss due to this broadband loading is automatically compensated by boosting the measured signal gain, assuming a 25 ohm signal source impedance.

This input attenuation of 5X also expands the single ended dynamic range at the solder tip by the same 5X factor to ± 3.0 V. (See Figure 6 on page 9.) The probe noise is also increased by the same 5X factor due to the solder tip attenuation.



CAUTION. *To avoid damaging the P75PST and P75TLRST solder tip resistors, do not allow the termination voltage to differ from either the A or B input voltage by more than 5 volts. The small size of the solder tip resistors expose them to thermal damage within the operating conditions of the probe.*

TriMode Operation

The TriMode feature of the P7600 Series probes is designed for improved convenience and enhanced capability in measuring differential signal quality. Since a differential signal is composed of two complementary single-ended signals, full characterization of differential signal quality requires more than a simple differential measurement. A TriMode probe features three Input Modes that allow a differential signal to be fully characterized with four measurements: differential, positive polarity and negative polarity single-ended, and common mode.

A TriMode probe provides improved efficiency and convenience by enabling full differential signal characterization from a pair of coaxial cable connections or a single soldered connection, depending on the type adapter used.

The P76CA-292C and P76CA-SMP coaxial adapters provide a pair of integral 6-inch coaxial leads with male 2.92 mm or female SMP connectors at the cable ends. The P76CA-292 adapter has two female 2.92 mm coaxial connectors to allow for an off-the-shelf or custom cable connection to the DUT. Coaxial adapters provide a TriMode signal ground connection through the integral DUT connector shield connections.

Using a P76TA adapter and one of the P7500 series solder tips available for the TriMode probes, (for example, the P75PST probe tip), probe connections are soldered to the two complementary signals (the A signal and the B signal) and a ground reference. From this single DUT (device under test) connection, the internal electronic switching control of the TriMode probe allows any one of the three probe Input Modes (four measurements) to be selected at a time. The TriMode probe inputs are routed on the probe ASIC (application-specific integrated circuit) to a set of four independent input amplifiers that perform the following signal calculations:

- $A - B$ (for differential signal measurement)
- $A - \text{GND}$ (for positive polarity single-ended measurement)
- $B - \text{GND}$ (for negative polarity single-ended measurement)
- $[A+B]/2 - \text{GND}$ (for common mode measurement)

NOTE. *In the B – GND Mode, the negative polarity B input is not inverted.*

The four input amplifiers are multiplexed together and only the selected Input Mode function is output to the connected oscilloscope. (See Figure 3 on page 7.) The figure shows a conceptual view of the TriMode probe input structure, where the C input provides the probe ground reference and is connected to the probe tip ground interconnect using the probe tip cable coaxial shields.

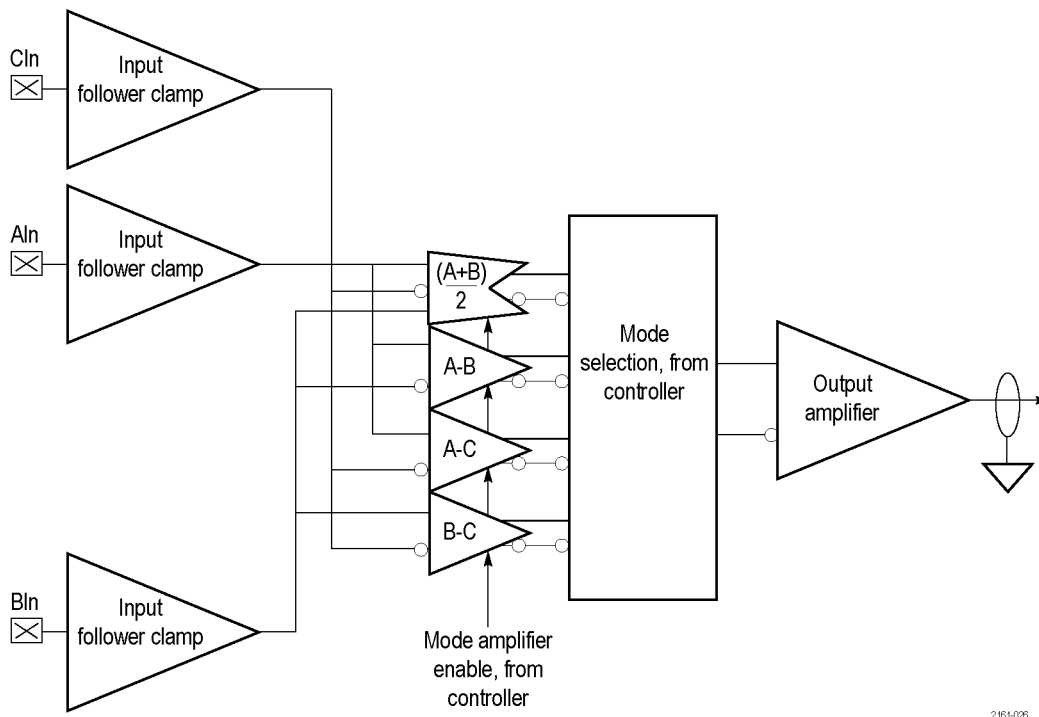

2161-035

Figure 3: TriMode input structure

On oscilloscopes that provide full TriMode support, the oscilloscope-controlled probe GUI (graphical-user interface) can perform a Probe Compensation operation on all Input Modes and Attenuation Settings at once using the Probe DC Calibration fixture that is supplied with the P7600 Series probe. (See the *P7600 Series Probes User Manual* for instructions on running the Probe Cal routine.) Full TriMode support will also allow storage and automatic recall of relevant settings like Offset Voltage and Termination Voltage. (See Figure 4.)

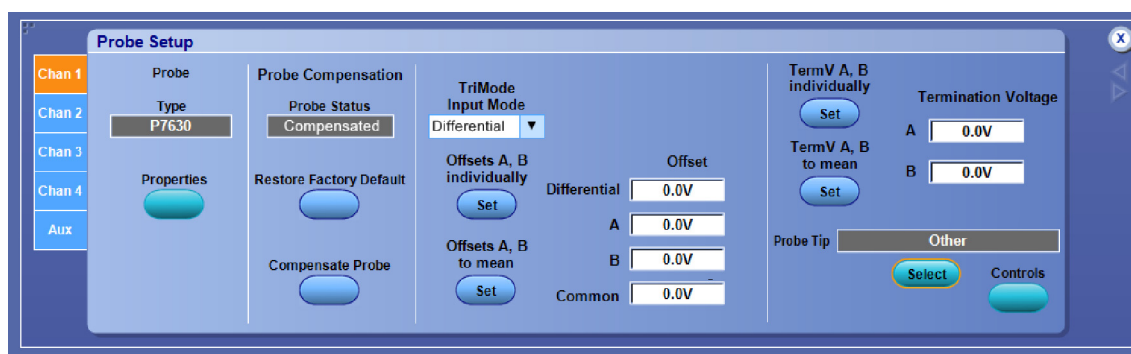

3026-036

Figure 4: Typical TriMode Probe Setup screen

Operating Voltages

The P7600 Series probes are designed to probe low-voltage circuits. Before probing a circuit, take into account the limits for the operating voltages discussed in this section.

- Input voltage
- Operating voltage window
- Input signal dynamic range
- Offset voltage
- Termination voltage

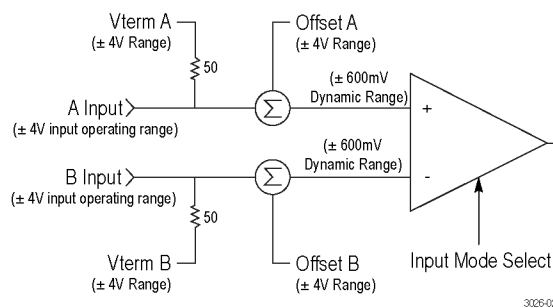

Figure 5: Probe inputs

Input Voltage

The maximum input voltage is the maximum voltage to ground that the inputs can withstand without damaging the probe input circuitry. The maximum input voltage differs between the type of adapter used; the limit for the coaxial adapters is ± 5 V (DC + peak AC). The P76TA solder tip adapter can withstand up to ± 8 V (DC + peak AC). To avoid damaging the resistors on the P75PST and P75TLRST solder tips, do not allow the A or B input voltage to differ from the termination voltage by more than 5 volts. The small size of the solder tip resistors expose them to thermal damage within the operating conditions of the probe.



CAUTION. To avoid damaging the inputs of the probe, when using the coaxial adapters, do not apply more than ± 5 V (DC + peak AC) between either probe input and ground.

When using the P76TA solder tip adapter, do not apply more than ± 8 V (DC + peak AC) between either probe input and ground.



CAUTION. To avoid ESD damage to the probe, always use an antistatic wrist strap (provided with your probe), and work at a static-approved workstation when you handle the probe.

Operating Voltage Window

The operating voltage window defines the maximum voltage that you can apply to each input, with respect to earth ground, without saturating the probe input circuitry. (See Figure 6.) A common-mode voltage that exceeds the operating voltage window may produce an erroneous output waveform even when the dynamic range specification is met. The single-ended voltage range (shown as squares in the figure below) represent the maximum signal swing at the dynamic range limits. The squares will shrink in size as the vertical scale factor is made more sensitive on the host oscilloscope.

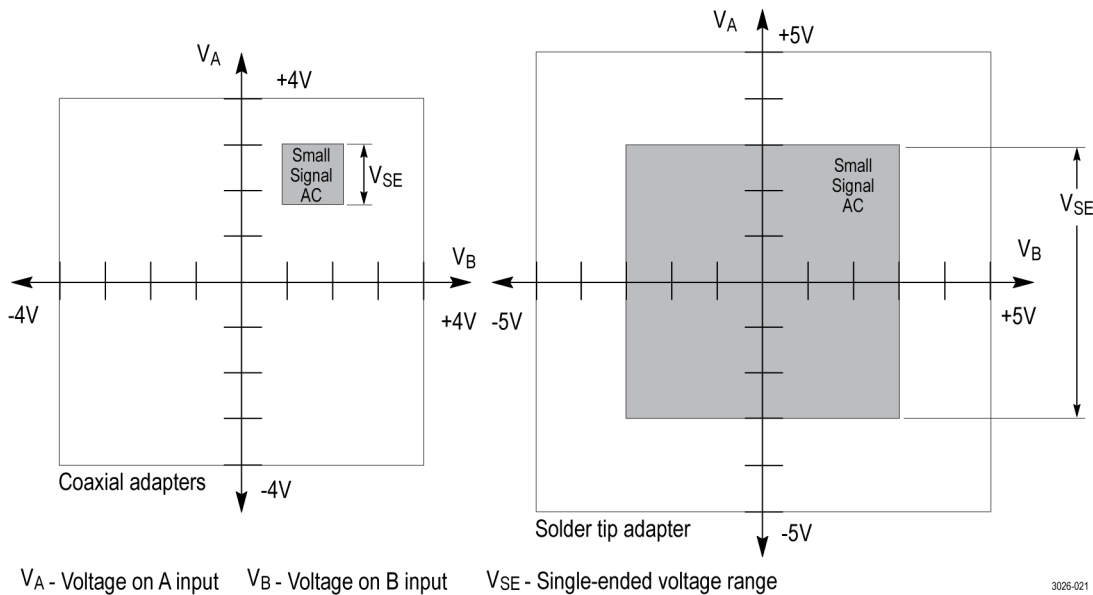

Figure 6: Operating voltage window

Input Signal Dynamic Range

The input signal dynamic range is the maximum voltage difference between the A and B inputs that the probe can accept without distorting the signal. The distortion from a voltage that exceeds this maximum can result in a clipped or otherwise inaccurate measurement. The graph on the following page illustrates the linearity error over the dynamic voltage range of the probe. (See Figure 7.)

The differential input mode dynamic range is specified to be almost twice as large as the single-ended signal dynamic range, but this is true only for complementary A and B input signals. The single-ended A and B dynamic range limits still apply, even for the case of a maximum differential mode input signal.

Offset Voltage

The probe A and B signal inputs are sensed, monitored, and averaged by probe internal circuitry and the sensed values are used by the automatic Offset Voltage Set control buttons. Two Set control buttons are available; set Individually and set to Mean.

The Offset Voltage Control, accessible from both the attached oscilloscope front-panel control and on-screen user interface, allows the probe dynamic range to be effectively moved up and down within the limits of the offset voltage range and the operating voltage window. When the offset voltage is set to zero volts and the input signal is zero volts (inputs shorted to ground, not open), the displayed signal should be zero volts. If a noticeable zero volt offset is present under the above conditions, a Probe Compensation operation should be performed. (See the *P7600 Series Probes User Manual*).

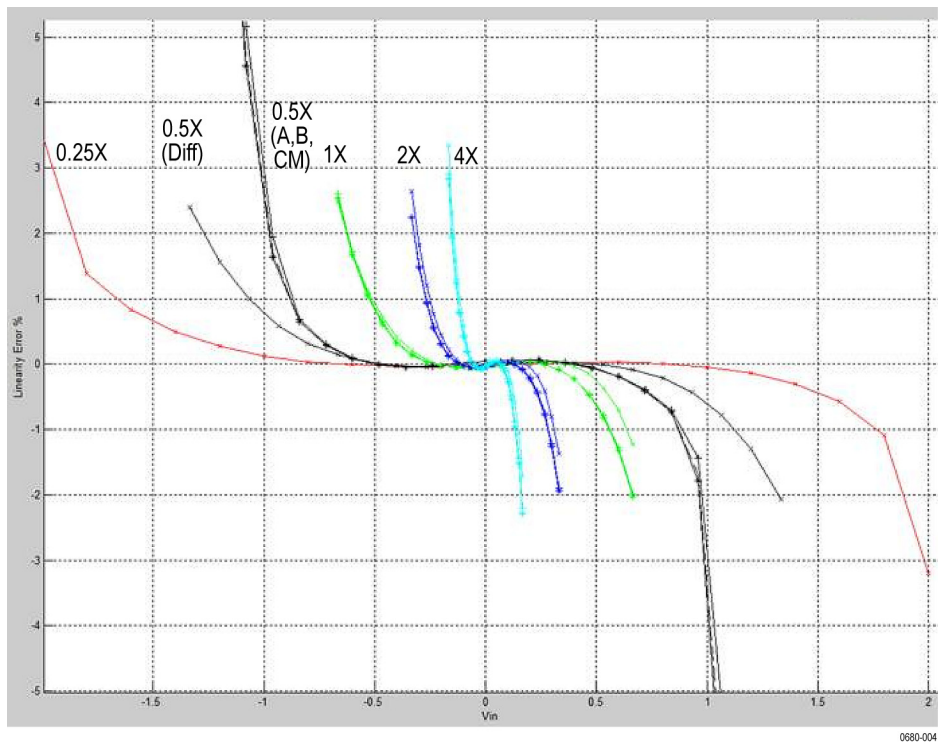

Figure 7: Dynamic range versus linearity

Termination Voltage

When the probe is used with a coaxial tip, it operates like an SMA-input probe similar to the Tektronix P7313SMA differential probe. Like an SMA-input probe, the P7600 Series probe and a coaxial adapter features a user-adjustable termination voltage, V_{TERM} , which can be controlled independently for both the A and B probe inputs. Adjustable termination voltage allows greater flexibility than is possible with the more conventional grounded termination, enabling the user to minimize DC probe loading from a DUT DC common-mode bias voltage.

The user interface on the oscilloscope allows you to select a preset termination voltage level (mean of both inputs or independent), based on the voltages sensed on the A and B inputs. You can also manually enter a value between -4.0 and $+4.0$ volts in the on-screen Termination Voltage field.

The diagonal overload limits shown in the figure below are the result of current limiting the termination voltage drivers to 50 mA. The flat upper and lower input overload limits are the result of specified voltage limits for the probe amplifier.

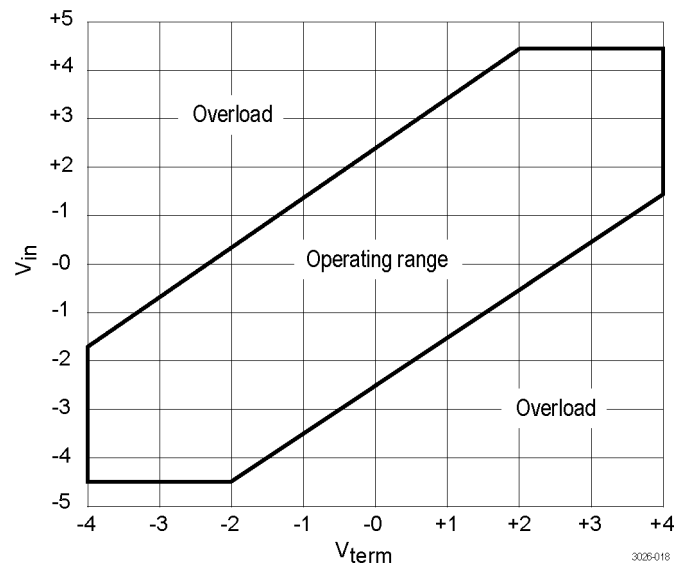

Figure 8: Termination voltage operating range

An important limitation of the termination voltage exists when you are using the P76TA adapter with the P75PST and P75TLRST solder tips. It is possible to damage the solder tips by applying too much voltage to the tips, through a combination of input and termination voltages.



CAUTION. To prevent exceeding the 62.5 mW power rating of the input resistors on the solder tips, do not allow the termination voltage to differ from the input voltage by more than 5 volts.

Autoset of Offset and Termination Voltage

You can set both the offset and termination voltages to levels that are unique for each input mode. For reference, the TriMode Input Mode field displays the active input mode in the Offset area of the Probe Setup screen.

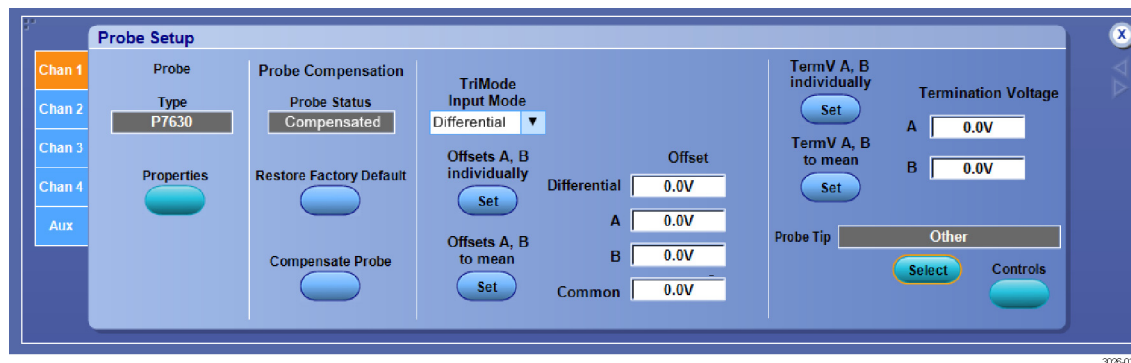

Figure 9: Probe Setup screen

Offset Voltage. The offset voltage control sums an adjustable DC voltage with the probe signal input. It is commonly used to null out an input DC bias voltage to center the input signal swing within the linear dynamic range of the probe input. The A and B probe inputs both have an independent offset voltage control. Each of the four TriMode input modes also have an independently-stored pair of offset voltage settings.

Offset voltages may be automatically generated by the probe and can be selected using the two Set buttons in the Offset section of the Probe Setup screen. You can also enter specific offset values directly in the Offset fields.

There are four manual Offset Voltage value entry fields which also display the current Offset Voltage settings. Although all four Offset Voltage value entry fields are active, only two of the control pairs are independent. The manual controls interact with each other as follows:

Adjusting the A or B settings affects the Differential and Common settings:

- $\text{Differential} = (A - B)$
- $\text{Common} = (A + B)/2$

Adjusting the Differential or Common settings affects the A and B settings:

- $A = \text{Common} + (\text{Differential}/2)$
- $B = \text{Common} - (\text{Differential}/2)$

Termination Voltage. The termination voltage control sets an adjustable DC voltage which drives the far end of the input termination resistor with a current limited DC termination voltage. It is generally used to minimize the DC loading of the probe on the input signal. The A and B inputs both have an independent termination voltage control.

Each of the four TriMode input modes also have an independently-stored pair of termination voltage settings. Termination voltages may be automatically generated by the probe and can be selected using the two Set buttons in the Termination Voltage section of the Probe Setup screen. You can also enter specific values for the A and B inputs directly in the Termination Voltage fields.

In general, the termination voltage autosest feature assumes that the input signal is being driven from a relatively low impedance signal source. If the termination voltage autosest button is activated when either the A or B probe input is open, the current termination voltage effectively drives the input sense signal used by the autosest feature. If the termination voltage autosest button is repeatedly actuated with an open probe input, the termination voltage setting will begin to ramp in the direction of the accumulated error voltage in the input sense signal path.

Input Impedance and Probe Loading

When you connect the probe inputs to a circuit, you are introducing a new resistance, capacitance, and inductance into the circuit.

Coaxial Adapters

Each input of the P76CA-xxx adapters provides a 50 Ω transmission line signal path from its input connector to the termination resistor at the probe amplifier input. (See Figure 10.) A P7600 Series probe coaxial tip simplified input schematic is shown in the figure below.

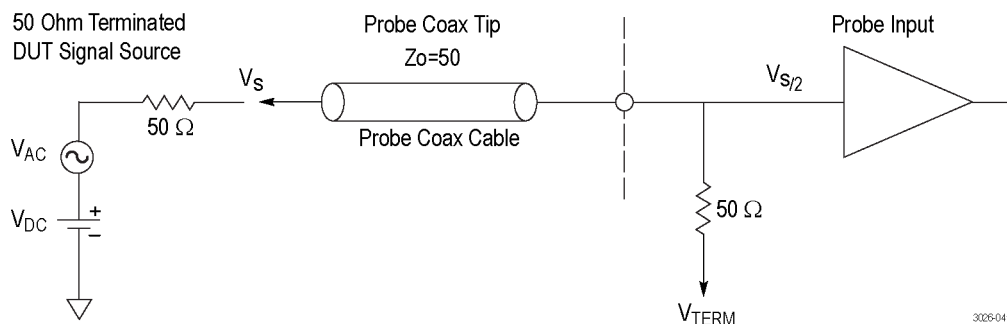

Figure 10: TriMode probe coaxial input model

The high frequency signals that the probe is designed to measure typically have a 50 ohm source impedance, as shown in the above schematic. The DUT signal, V_s , is transmitted to the probe coaxial tip through a 50 ohm transmission line. The probe input termination resistor is intended to provide a low discontinuity termination for the DUT signal.

The DUT signal source, V_s , is represented in the above schematic as appearing at the input to the probe coaxial adapter. The P7600 Series probe coaxial adapters are calibrated to the adapter connectors for either AC or DC signals and are compensated for the small DC signal loss in the coaxial adapter signal path.

The signal gain through the probe amplifier, when used with a coaxial adapter, is represented as a unity gain factor multiplied times the selected step gain. The probe amplifier step gain is selected by the host oscilloscope control interface, based on the user-selected vertical scale factor for the vertical channel to which the probe is attached.

Solder Tip Adapter

The P76TA adapter provides a probe tip connection interface that enables P7500 Series TriMode probe tips to be attached to a P7600 Series probe. P7500 Series probe tips have a nominal 5X attenuation structure when used with a 50 Ω input termination device like the P7600 Series probes.

The use of a passive attenuation input pick-off resistor at the P7500 Series probe tip means that the P7600 Series probes act like a Z0 probe when used with a P76TA adapter and P7500 Series probe tip. This 5X Z0 probe structure reduces probe loading enough that it is possible to use the P7600 Series probes and P76TA adapter for making probing measurements anywhere along the signal transmission line path, as shown in the simplified schematic below. (See Figure 11.)

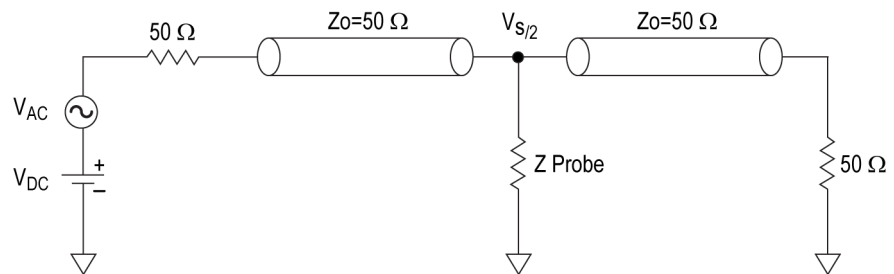

3026-044

Figure 11: P76TA adapter simplified schematic

The probe diagram above shows a probe measurement being made on a doubly-terminated signal path. This doubly-terminated signal path is a common structure for many high frequency signaling standards, since, if implemented correctly, it provides a very low-discontinuity signal path.

The 50 Ω back termination at the signal transmitter absorbs reflected signals from reverse-path discontinuities on the signal transmission line, including those due to probe loading. The additional 50 Ω termination resistor at the end of the transmission line path also serves to absorb the transmitted signal power and any forward-path signal reflections from discontinuities on the signal transmission line. This doubly-terminated signal structure results in an effective 25 ohm signal source impedance. (See Figure 12.)

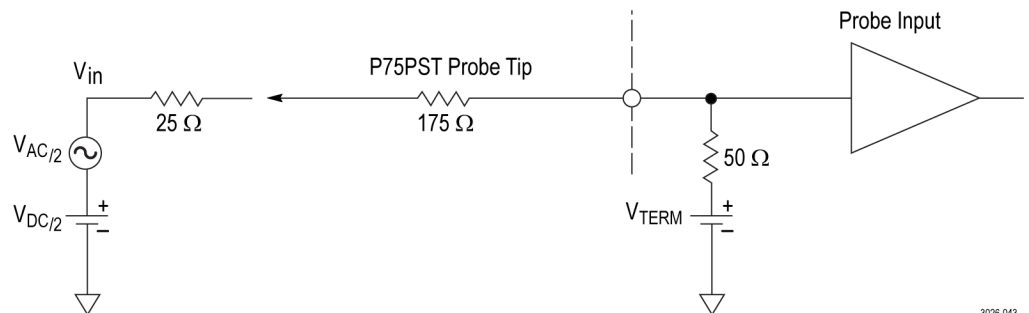

3026-043

Figure 12: P76TA adapter and P75PST tip equivalent schematic

Scale Factor

In many of the high-frequency signaling standards that the P7600 Series probes are designed for, a 50 Ω termination at the transmitter is in parallel with another 50 Ω termination at the end of the transmission line path, effectively making a 25 Ω signal source impedance. (See Figure 12.)

When the P76TA adapter and P75PST or P75TLRST tips are used to probe the DUT within the transmission line path, this 25 Ω source impedance must be considered a part of the probe input attenuator structure, and therefore be included when calculating the probe gain.

Using the formula:

$$\text{Ext Atten} = (\text{Rsource} + 225 \Omega) / 225 \Omega$$

where the 225 Ω represents the input resistance of one half of the solder tip differential input, substituting 25 Ω for the Rsource impedance yields an external attenuation factor of 1.1116.

The probe/oscilloscope signal gain is factory-calibrated at the P76TA probe tips using this external attenuation factor of 1.1116, and is accurately scaled by the vertical volts/div control on the host oscilloscope.

For systems with source impedances not equal to 25 Ω , it may be necessary to adjust the oscilloscope EXT ATTEN scale factor and the offset voltage to optimize the measurement accuracy. You may also need to adjust the probe termination voltage control to null out the DC loading effect of the probe.

Probing Techniques to Maximize Measurement Fidelity

Measurement fidelity is an indication of how accurately a probe represents the signal being measured. The measurement fidelity of the probe is best when the probe is connected to the circuit with the P76CA-xxx probe adapters. The P76CA-292C and P76CA-SMP adapters both include a pair of 6 inch, low-loss, skew-matched cables. When using the P76CA-292 adapter, only use matched, ideally matched high-quality cables to complete the connection to your circuit.

When you use the P76TA adapter with P7500 series probe tips, proper wire lead length is critical for achieving good measurement results. Recommendations for connecting the P7500 probe tips are given in the following section.

The P7600 Series probes contain S-parameter characterization data for the probes, which are downloaded to the attached oscilloscope when the probe is first connected. This probe-specific data is used along with nominal probe adapter data to generate DSP correction filters that are used for improved high frequency measurement accuracy. After the probe adapter is attached to the probe, the adapter transfers identification data which is used as part of the generated filter process.

P76CA-xxx Adapters

To prevent damage and prolong connector and cable life, the cable and center conductors must not twist when making connections. Always use a wrench to minimize the cable twist when you connect and disconnect the 2.92 adapters and cables. Use a torque wrench to tighten the connectors to 8 in-lbs. Failure to do so will shorten the service life of the adapters.

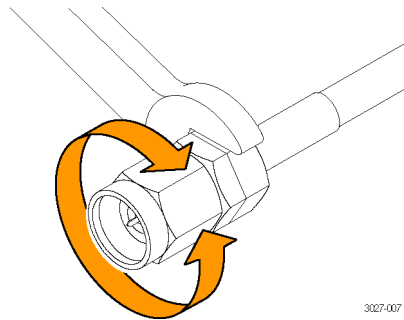

3027-007

Figure 13: Preventing twist to the coaxial input cables

P76TA Adapter with P7500 TriMode Solder Tips

There are several solder tips available for connecting the P7500 Series probes to your circuit. The P75PST and P75TLRST probe tips solder directly to your circuit through small wires. (See Figure 14 on page 18.) Two resistor solder tips are also available; these tips include input resistors that solder to your circuit and can be replaced if damaged.

P75PST and P75TLRST TriMode Solder Tips. The P75PST and P75TLRST probe tips are each composed of a small form factor interconnect circuit board with

SMD0402 damping resistors and a set of vias for wire attachment to the DUT (Device Under Test). The circuit board vias are designed for both 4 mil and 8 mil wire, and a special high tensile strength wire is supplied as part of the wire accessory kit. The expanded view of the probe tips shows the location of the A and B signal inputs as well as the two ground reference connections.

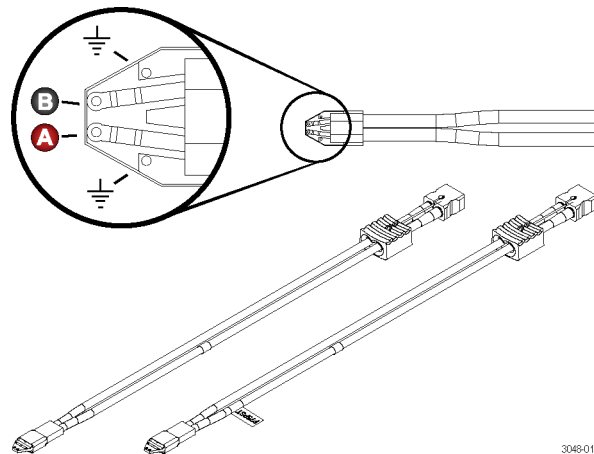

Figure 14: P75PST and P75TLRST TriMode Solder Tips

The recommended wire attachment method is to first solder the wires to the DUT, being careful to minimize the wire length of the signal and ground connections. Next, attach a solder ramp to the bottom of the solder tip with hot glue. A kit of solder ramps are included with the P76TA adapter. A notch on the ramp aligns with the bottom of the tip.

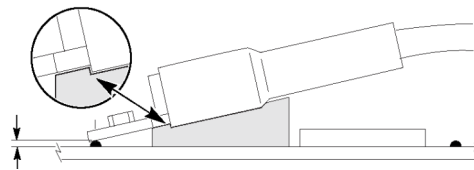

Figure 15: Solder ramp installed

The solder ramps are designed to point the front of the solder tip downward to minimize the distance between the solder points on the solder tip and the circuit test points. For signal frequencies that exceed 25 MHz, this distance must be less than 0.032 in. (0.8 mm) to achieve good results.

Once the solder ramp is secured to the tip, thread the wires through the probe tip board vias, being careful to achieve as symmetrical a wire pattern as possible between the two signal inputs and a very short ground connection. Secure the tip/ramp assembly to the DUT with tape or hot glue, and finally, solder the wires on top of the probe tip circuit board. Any excess wire lead length extending through the probe tip board should be removed to minimize possible signal reflection problems.

Because of the limited mechanical strength of the wire interconnect and probe tip circuit board, the solder-down probe tip should be taped down at the DUT for strain relief. Although the accessory kit includes adhesive strips that can be used for the strain relief of the probe tip, the use of mylar tape will generally provide stronger attachment if room is available at the DUT.

Probe Tip Cables and Connectors. Attached to the probe tip circuit board is a pair of very low skew (<1ps) coaxial cables and a polarized G3PO dual connector block. The 3GPO connectors use a miniature, high frequency design that enables quick and easy installation of the P7500 Series solder tips. The G3PO connector block of the probe tip is inserted into the input of the P76TA adapter. The adapter contains a mating, polarized G3PO connector block with attached G3PO connector bullets.

The connector bullets are a part of the G3PO connector design, providing a self-aligning interconnect mechanism between G3PO connectors. The G3PO connector in the adapter is designed to have higher detent force than the probe tip connectors, which is intended to ensure that the G3PO bullets remain in the P76TA adapter connector when disconnected. The adapter, with its integral spring mechanism, helps to provide a self-aligning mechanism for hand insertion of the probe tip. The adapter springs also give a secure capture of the probe tip connector after insertion. Release of the probe tip is assisted by using the wire-connected cable release holder on the probe tip connector. This probe tip release holder should always be used rather than pulling on the probe tip cables, which may cause tip cable damage.

DUT Connections. The lead length of the resistor leads and connection wires between the probe tip board and the DUT must be kept as short as possible to preserve the integrity of the measured signal. Typical wire lengths range from 0.010 in. to 0.100 in. (See Figure 16.)



3048-012

Figure 16: Typical wire length from probe tip to circuit

The following four figures illustrate the signal integrity effect on the P75TLRST solder tip when used with different lengths of tip wire. Signal fidelity is best when the wire length is kept as short as possible. The step generator that was used as a signal source for these screenshots has a 30 ps 10-90% rise time. The table in each figure contains data for two rise time measurements (10-90% and 20-80%).

These screenshots can be used as a rough guide to gauge the effects of wire length, but actual results may vary depending on the other factors like characteristics of the device under test (for example, rise time and impedance), precision of the solder connection, and the model of oscilloscope.

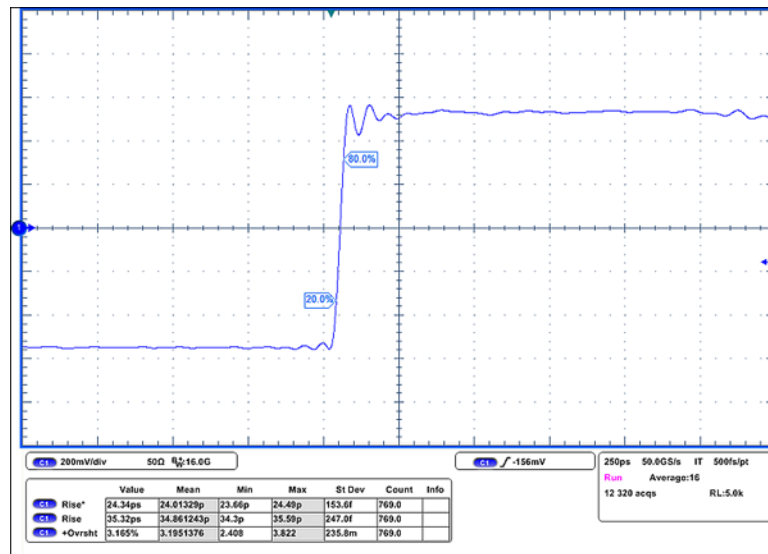

Figure 17: P75TLRST solder tip with 0.010 in. of tip wire

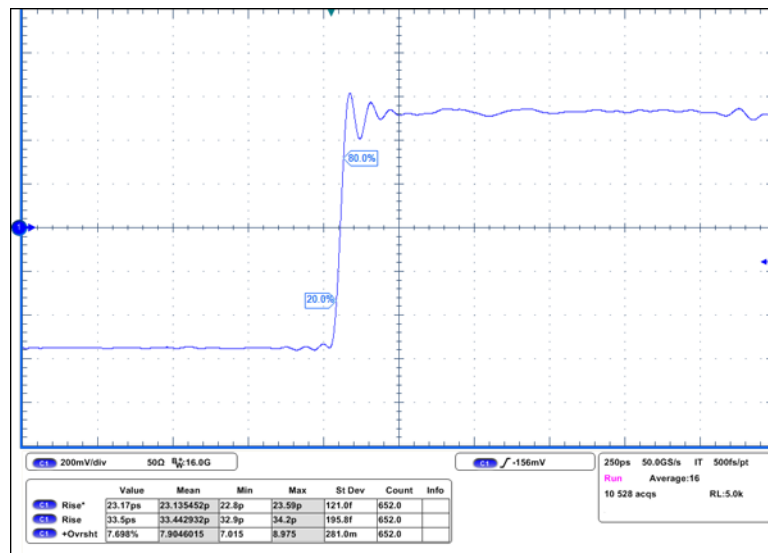

Figure 18: P75TLRST solder tip with 0.050 in. of tip wire

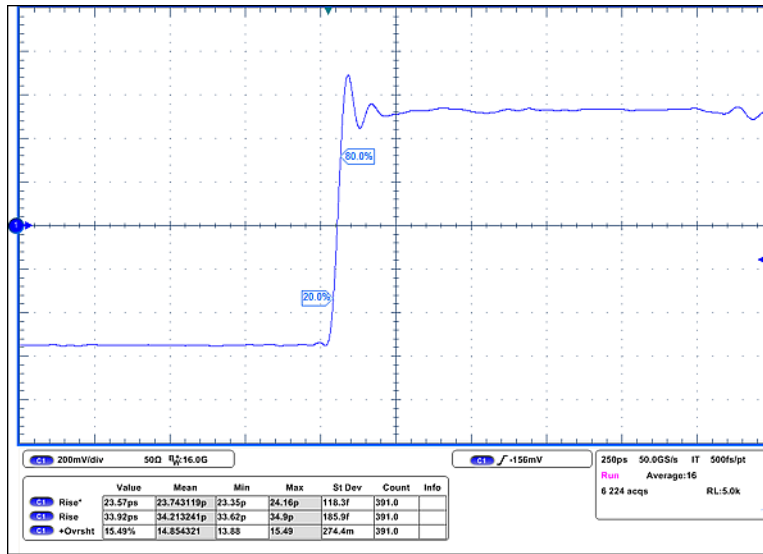

Figure 19: P75TLRST solder tip with 0.100 in. of tip wire

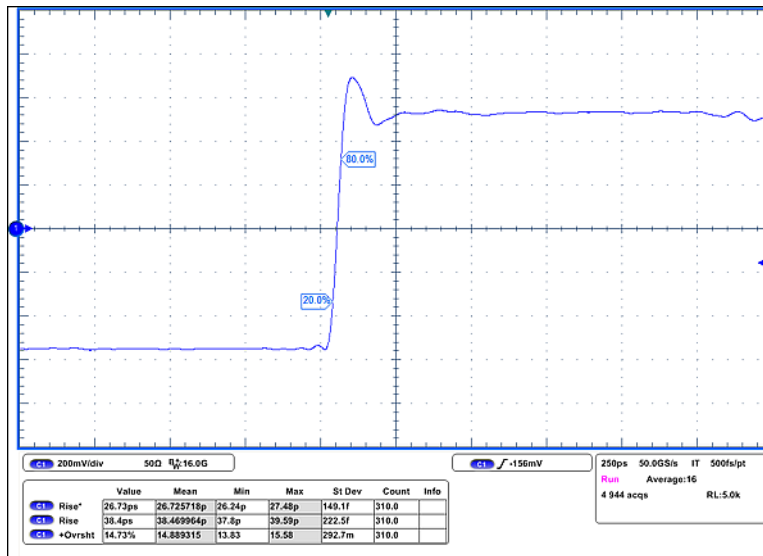

Figure 20: P75TLRST solder tip with 0.200 in. of tip wire

Reference

This section contains information about taking measurements with the probe and increasing measurement accuracy.

Single-Ended Measurements Using A and B Modes

A differential probe, such as a P7600 Series probe, can be used for single-ended measurements within the limits of its dynamic and offset voltage ranges. Single-ended probes such as the P7240 typically have a wider offset range than differential probes, but with much lower bandwidth performance. (See Table 1.)

Table 1: Offset ranges

Probe	Attenuation	DC offset	Dynamic range
P7240	5X	+/- 5 V	4 V _{PP}
P7513 & P7516 (differential mode)	5X	+2.5 V, -1.5 V	1.5 V _{PP}
P7513 & P7516 (single-ended and common-mode)	5X	+3.4 V, -1.8 V	1.5 V _{PP}
P7520 (differential mode)	5X	+2.5 V, -1.5 V	1.25 V _{PP}
P7520 (single-ended and common-mode)	5X	+3.4 V, -1.8 V	1.25 V _{PP}
P76xx ¹	Coaxial adapters	1X	+/- 4 V
		1X	2.0 V _{PP} (differential)
	Solder tip adapter	5X	+/- 4 V
		5X	10.0 V _{PP} (differential)

¹ The P7600 Series probes have independent A and B input offset controls. To take a single-ended measurement, use the B input for reference and set the B offset to ground or the reference level of the measured signal. Set the A signal offset to the DC common-mode voltage of the measured signal.

Differential probes are ideal for a class of single-ended measurements where the reference voltage is not ground:

- SSTL_{1,2}: $V_{TT}, V_{REF} = V_{DD}/2$
- PECL: $V_{REF} = V_{CC}-1.3$

To measure single-ended signals in this class, connect the B input of the probe to V_{REF} .

A differential probe in these applications displays the true signal despite any AC or DC variation in V_{REF} from its nominal value. A single-ended probe displays the signal plus the variation in V_{REF} . Differential probes can also be used to make ground referenced single-ended measurements on either single-ended signals or differential signals like PCI Express or Serial ATA.

Single-ended measurements on differential signals are used to measure common mode voltage and check for differential signal symmetry. By using a TriMode probe, you can easily take these measurements with one adapter connection (two coax cables or a grounded solder tip). Cycle the Input Mode switch to display the signal that you want to view.

Differential Measurements

A differential probe is optimized to measure high speed differential signals. Differential signals are formed from two complementary signals with a common reference voltage. (See Figure 21.)

Devices designed for differential measurements avoid problems presented by single-ended systems. These devices include a variety of differential probes, differential amplifiers, and isolators.

A differential probe is basically a differential amplifier, which is used to make differential measurements that reject any voltage that is common to the inputs and amplifies any difference between the inputs. Voltage that is common to both inputs is often referred to as the Common-Mode Voltage (V_{CM}) and voltage that is different as the Differential-Mode Voltage (V_{DM}).

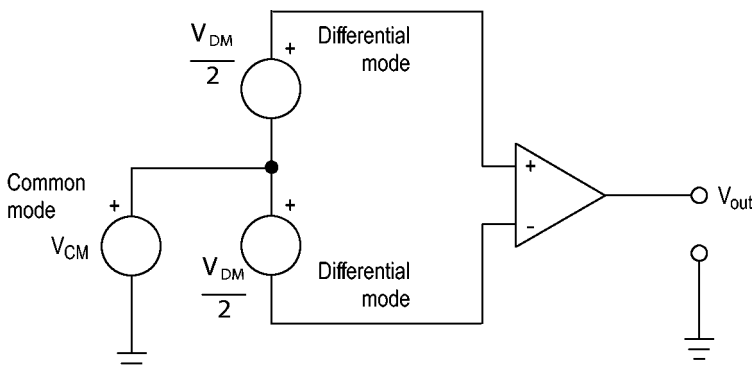

Figure 21: Simplified model of a differential amplifier

Common-Mode Rejection Ratio

Differential amplifiers cannot reject all of the common-mode signal. The ability of a differential amplifier to reject the common-mode signal is expressed as the Common-Mode Rejection Ratio (CMRR).

The DC CMRR is the differential-mode gain (A_{DM}) divided by the common-mode gain (A_{CM}). It is expressed either as a ratio or in dB:

$$DC\ CMRR = \frac{A_{DM}}{A_{CM}} \quad DC\ CMRR\ (dB) = 20 \log \left| \frac{A_{DM}}{A_{CM}} \right|$$

AC CMRR for the probe is defined using 3-port, mixed-mode S-parameters as:

$$20 \log \left| \frac{S_{SD21}}{S_{SC21}} \right| - 6\ dB$$

for the measured differential mode response, where A input = S1, B input = S2 and Output = S3. The 6 dB term in the AC CMRR equation gives the voltage-referenced response. CMRR generally is highest (best) at DC and degrades with increasing frequency. A typical CMRR plot for the P7600 Series probes is shown. (See Figure 22 on page 25.)

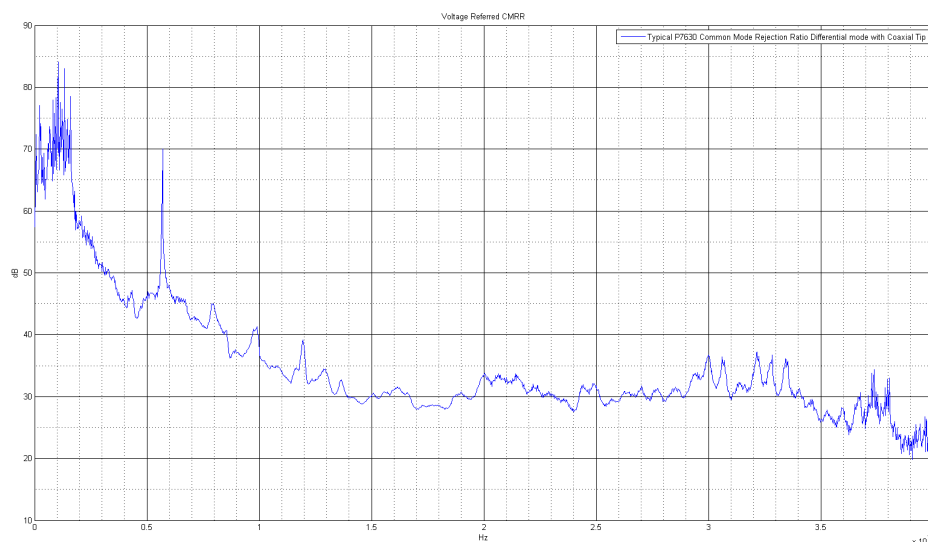

Figure 22: Typical CMRR

Assessing CMRR Error

The CMRR of the P7600 Series probes is shown in graphs assuming a sinusoidal common-mode signal. A quick way to assess the magnitude of CMRR error when the common-mode signal is not sinusoidal is to connect both leads to the same point in the circuit. The oscilloscope displays only the common-mode component that is not fully rejected by the probe. While this technique may not yield accurate measurements, it does allow you to determine if the magnitude of the common-mode error signal is significant. When using the solder-down tips, keep the tip leads the same length to maximize the probe CMRR.

Input Impedance Effects on CMRR

The lower the input impedance of the probe relative to the source impedance, the lower the CMRR for a given source impedance imbalance. Differences in the source impedance driving the two inputs lowers the CMRR. Note that single-ended measurements generally result in asymmetric source impedances which tend to reduce the differential mode CMRR.

Differential-Mode Rejection

When making common-mode signal measurements ($A+B/2 - GND$) with the TriMode probe, it is desirable to reject the differential-mode signal present between the two inputs. This rejection is expressed as the Differential-Mode Rejection Ratio (DMRR).

AC DMRR for the probe is defined using 3-port, mixed-mode S-parameters as:

$$20 \log \left| \frac{S_{SC21}}{S_{SD21}} \right| + 6 \text{ dB}$$

for the measured common mode response. The 6 dB term in the AC DMRR equation gives the voltage-referenced response.

Channel Isolation

Under ideal conditions when taking single-ended measurements with a differential probe, no part of a signal applied to one input of the probe would appear on the other input. In reality some portion of the signal on one input does “bleed” over to the other input, and this effect increases with frequency. Channel isolation is a measure of how much crosstalk occurs between the two probe inputs. The channel isolation is defined with S-parameter measurements below, where:

A input = S1, B input = S2, Output = S3

A ISOLATION = $20 \log (S_{31} / S_{32})$ | A Mode

B ISOLATION = $20 \log (S_{32} / S_{31})$ | B Mode

A typical isolation plot for the P7600 Series probes using a coaxial adapter is shown below. When the probe is used with the P76TA adapter and solder tips, note that channel isolation performance is highly dependent on probe tip attachment lead length. Good channel isolation requires keeping the interconnect lead length for both signal and ground connections very short. (See Figure 23.)

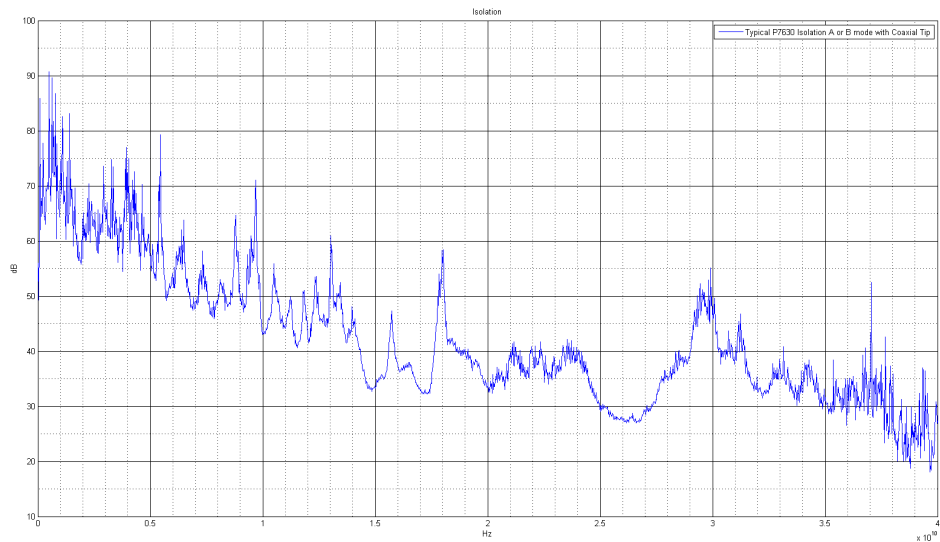

Figure 23: Typical channel isolation

Specifications

These specifications apply to the P7600 Series probes when installed on a DPO70000SX, DPO/DSA73304D, or MSO/DPO73304DX oscilloscope. The probe and oscilloscope must have a warm-up period of at least 20 minutes and be in an environment that does not exceed the allowed limits. (See Table 3.)

Specifications for the P7600 Series TriMode Probes fall into three categories: warranted, typical, and nominal characteristics.

Warranted Characteristics

Warranted characteristics describe guaranteed performance within tolerance limits or certain type-tested requirements.

Table 2: Warranted electrical characteristics

Characteristic	P76CA-292	Coaxial adapters		Solder tip adapter
		P76CA-292C	P76CA-SMP	P76TA
DC gain accuracy	±2%	±2%	±2%	±2%
DC output zero common mode imbalance ¹	±4 mV	±4 mV	±4 mV	±4 mV
Operating voltage window	-4.0 V to +4.0 V	-4.0 V to +4.0 V	-4.0 V to +4.0 V	-5.0 V to +5.0 V
Input signal range				
Single-ended	1.2 Vp-p	1.2 Vp-p	1.2 Vp-p	6.0 Vp-p
Differential	2.0 Vp-p	2.0 Vp-p	2.0 Vp-p	10.0 Vp-p
Linearity	±1%	±1%	±1%	±1%
Offset voltage range	-4.0 V to +4.0 V	-4.0 V to +4.0 V	-4.0 V to +4.0 V	-4.0 V to +4.0 V
Offset voltage accuracy (referred to input)	±(2% of FS range + 6 mV)	±(2% of FS range + 6 mV)	±(2% of FS range + 6 mV)	±(2% of FS range + 30 mV) (25 Ω source Z)
DC offset drift (referred to input)	<±0.2 mV/ °C	<±0.2 mV/ °C	<±0.2 mV/ °C	<±0.2 mV/ °C
Termination voltage range	-4.0 V to +4.0 V	-4.0 V to +4.0 V	-4.0 V to +4.0 V	-4.0 V to +4.0 V
Termination voltage accuracy	<±10 mV	<±10 mV	<±10 mV	<±10 mV
Maximum nondestructive input voltage ²	±5 V _(DC + peak AC)	±5 V _(DC + peak AC)	±5 V _(DC + peak AC)	±8 V _(DC + peak AC)

Specifications

Characteristic	P76CA-292	Coaxial adapters		Solder tip adapter
		P76CA-292C	P76CA-SMP	P76TA
Input impedance				
Differential				450 Ω @1 GHz 200 Ω @10 GHz 150 Ω @25 GHz
Single-ended				225 Ω @1 GHz 150 Ω @10 GHz 100 Ω @25 GHz
Input return loss				
Freq to 5 GHz	>20 dB	>20 dB	>20 dB	
Freq to 20 GHz	>12 dB	>12 dB	>12 dB	
Freq to 30 GHz	>10 dB	>10 dB	>10 dB	
Freq to 33 GHz	>8 dB	>8 dB	>8 dB	
Noise, system, DSP corrected (most sensitive range)				
P7633	<1.1 mVrms	<1.1 mVrms	<1.1 mVrms	<5.0 mVrms
P7625	<0.9 mVrms	<0.9 mVrms	<0.9 mVrms	<5.0 mVrms
Overload indicator range (P76CA-xxx adapters only)	Vterm	Overload off	Overload on	
	-4 V	-4.25 <Vin< -1.75	Vin< -4.75 or Vin> -1.00	
	-3 V	-4.25 <Vin< -0.75	Vin< -4.75 or Vin> -0.15	
	-2 V	-4.25 <Vin< +0.25	Vin< -4.75 or Vin> +0.75	
	-1 V	-3.25 <Vin< +1.25	Vin< -3.75 or Vin> +1.75	
	0 V	-2.25 <Vin< +2.25	Vin< -2.75 or Vin> +2.75	
	+1 V	-1.25 <Vin< +3.25	Vin< -1.75 or Vin> +3.75	
	+2 V	+0.25 <Vin< +4.25	Vin< -0.75 or Vin> +4.75	
	+3 V	+0.75 <Vin< +4.25	Vin< +0.25 or Vin> +4.75	
	+4 V	+1.75 <Vin< +4.25	Vin< +1.25 or Vin> +4.75	

¹ Measured at the output of the probe, relative to the DC output zero common mode voltage reported as the calibrated value in the TekConnect message for each step gain and input mode combination.

² Measured between each input or between either probe input and ground.

Table 3: Warranted environmental characteristics

Characteristic	Specification
Temperature	
Operating	0 to 40 °C (+32 to +104 °F)
Nonoperating	-20 to +60 °C (-4 to +140 °F)
Humidity	
Operating	20–80% RH, at up to +40 °C (+104 °F)
Nonoperating	5–90% RH
Altitude	
Operating	3000 meters (10,000 feet)
Nonoperating	12,000 meters (40,000 feet)

Typical Characteristics

Typical characteristics describe typical but not guaranteed performance.

Table 4: Typical electrical characteristics

Characteristic	Coaxial adapters			Solder tip adapter
	P76CA-292	P76CA-292C	P76CA-SMP	P76TA
Rise time, system, DSP corrected				
P7633				
10% – 90%	<14 ps	<14 ps	<14 ps	<16 ps
20% – 80%	<11 ps	<11 ps	<11 ps	<12 ps
P7625				
10% – 90%	<18 ps	<18 ps	<18 ps	<18 ps
20% – 80%	<14 ps	<14 ps	<14 ps	<14 ps
Bandwidth ¹				
P7633				
Probe only	>33 GHz (all input modes)			
System, DSP corrected	>33 GHz (all input modes)	>33 GHz (all input modes)	>33 GHz (all input modes)	>30 GHz (A, B, D modes) >25 GHz (common mode)
P7625				
Probe only	>25 GHz (all input modes)			
System, DSP corrected	>25 GHz (all input modes)	>25 GHz (all input modes)	>25 GHz (all input modes)	>25 GHz (all input modes)

Table 4: Typical electrical characteristics (cont.)

Characteristic	Coaxial adapters			Solder tip adapter
	P76CA-292	P76CA-292C	P76CA-SMP	P76TA
Rise time, probe only				
P7633				
10% –90%	<14 ps	<14 ps	<14 ps	
20% –80%	<11 ps	<11 ps	<11 ps	
P7625				
10% –90%	<18 ps	<18 ps	<18 ps	
20% –80%	<14 ps	<14 ps	<14 ps	
Input sense voltage accuracy ²	Input sense voltage = $V_{in} \pm 24$ mV	Input sense voltage = $V_{in} \pm 24$ mV	Input sense voltage = $V_{in} \pm 24$ mV	Input sense voltage = $V_{in} \pm 100$ mV
Common-mode rejection ratio, differential-mode	>40 dB @ DC >14 dB to 15 GHz >6 dB to 30 GHz >4 dB to 33 GHz	>40 dB @ DC >14 dB to 15 GHz >6 dB to 30 GHz >4 dB to 33 GHz	>40 dB @ DC >14 dB to 15 GHz >6 dB to 30 GHz >4 dB to 33 GHz	
Differential-mode rejection ratio, common-mode	>26 dB to 20 GHz >18 dB to 30 GHz >15 dB to 33 GHz	>26 dB to 20 GHz >18 dB to 30 GHz >15 dB to 33 GHz	>26 dB to 20 GHz >18 dB to 30 GHz >15 dB to 33 GHz	
Channel isolation, single-ended mode	>20 dB to 20 GHz >12 dB to 30 GHz >10 dB to 33 GHz	>20 dB to 20 GHz >12 dB to 30 GHz >10 dB to 33 GHz	>20 dB to 20 GHz >12 dB to 30 GHz >10 dB to 33 GHz	

¹ Measurements taken @18 to 28 °C (+64 to +82 °F)

² The voltages on the probe inputs are sensed by the probe circuitry, and are used to generate voltages associated with the Set buttons on the oscilloscope GUI. The Set buttons are used to automatically enter these generated Offset and Termination voltages in the on-screen fields; either Individually or Mean values can be selected.

Table 5: Typical mechanical characteristics

Characteristic	Description
Dimensions, control box	125.4 mm × 41 mm × 35 mm (4.9 in × 1.6 in × 1.4 in)
Dimensions, probe body	101.6 mm × 8.89 mm × 19 mm (4.0 in × 0.350 in × 0.750 in)
Dimensions, probe main cable length	1.2 m (47.2 in) (from the front of the probe body to the rear of the control box; does not include adapter)
Unit weight	1.860 kg (4.1 lbs) (probe, accessories and packaging)

The following figures show the typical rise time and frequency response of the probes.



Figure 24: Typical rise time

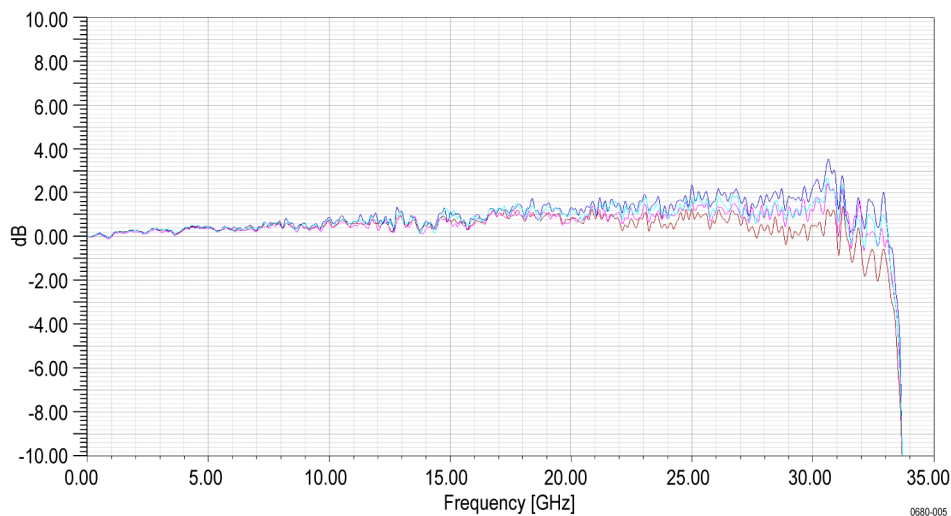

Figure 25: Typical frequency response

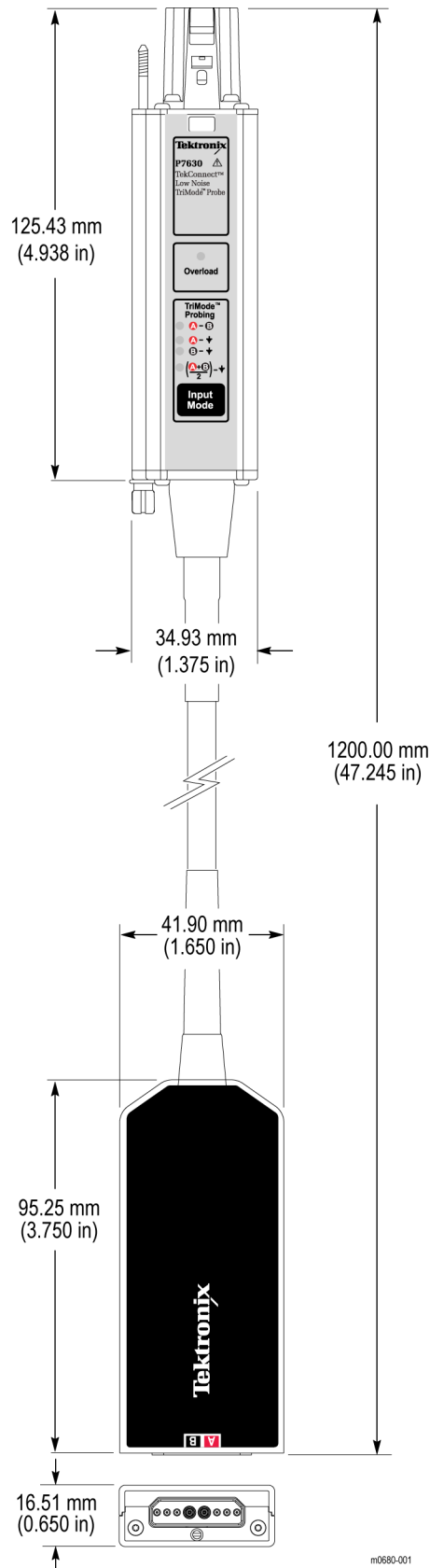
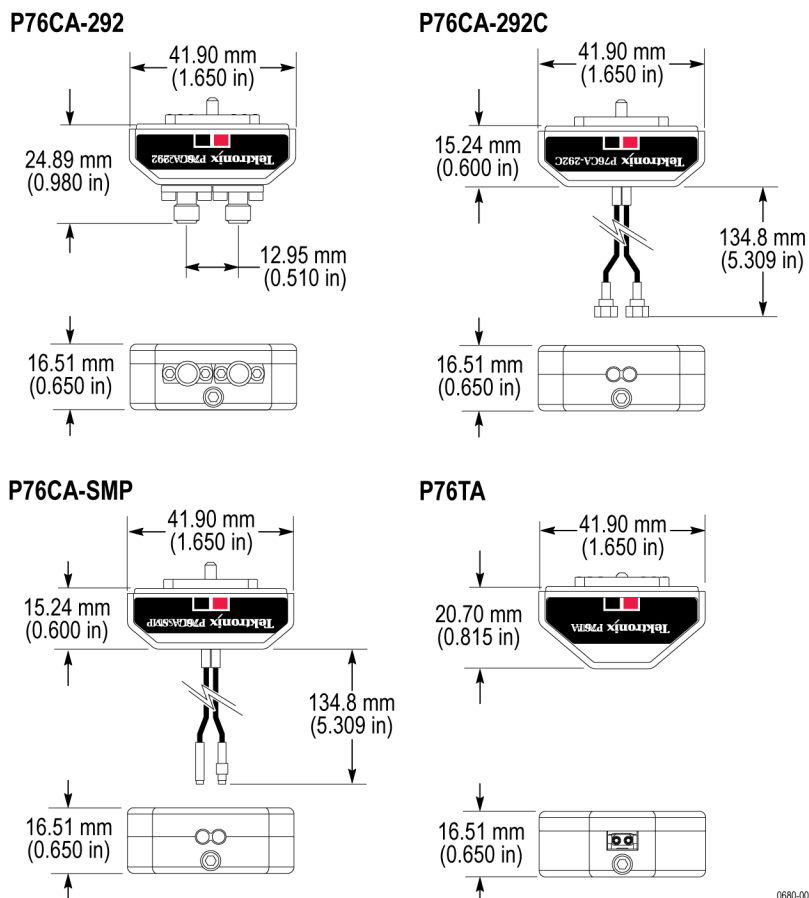
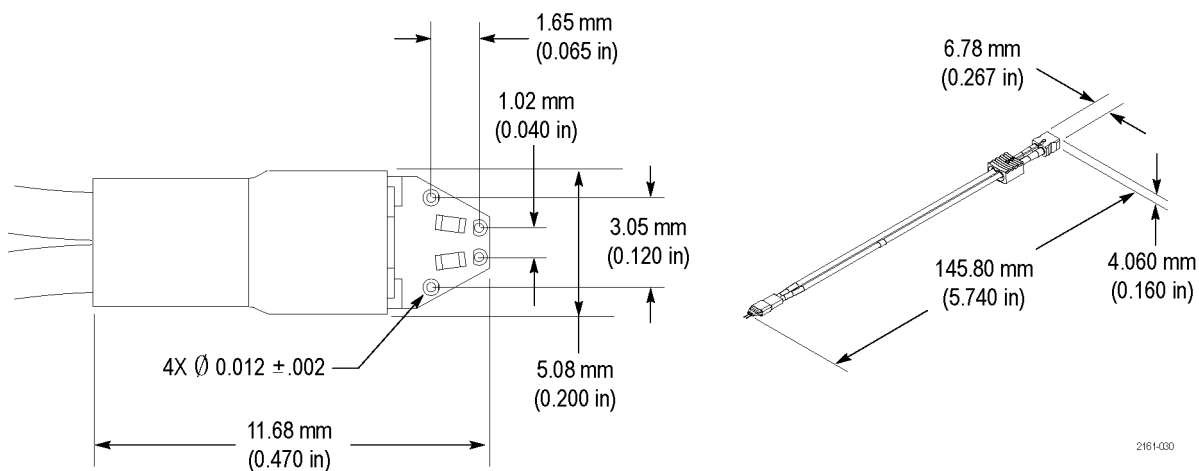

Figure 26: Probe body and control box dimensions



0680-003

Figure 27: P7600 Series Probe adapter dimensions



2161-030

Figure 28: P75PST and P75TLRST solder tip dimensions

Nominal Characteristics

Nominal characteristics describe guaranteed traits, but the traits do not have tolerance limits.

Table 6: Nominal electrical characteristics

Characteristic	Coaxial adapters			Solder tip adapter
	P76CA-292	P76CA-292C	P76CA-SMP	P76TA
Maximum power dissipation				
Termination resistor	125 mW	125 mW	125 mW	N.A.
Probe tip	N.A.	N.A.	N.A.	62.5 mW ¹
Input resistance	50 $\Omega \pm 2 \Omega$	50 $\Omega \pm 2 \Omega$	50 $\Omega \pm 2 \Omega$	225 Ω
Input capacitance	N.A.	N.A.	N.A.	0.1 pF

¹ P75PST and P75TLRST solder tips

Table 7: Nominal adapter electrical characteristics

Characteristic	Connector type	Description
Input configuration		
P76CA-292 Adapter	2.92 mm coaxial female ¹	Differential (two coaxial signal inputs, A and B; outer cable shields are grounds)
P76CA-292C Adapter	2.92 mm coaxial male (cables)	
P76CA-SMP Adapter	SMP coaxial female (cables)	
P76TA Adapter with:		
P75PST solder tip	0.012 in-diameter solder vias	Differential (two signal inputs, A and B; shared with single-ended)
P75TLRST solder tip	0.012 in-diameter solder vias	Single-ended (one each A and B signal input and two ground inputs)

¹ User-supplied cables

User Service

This section covers troubleshooting and probe maintenance. If your probe does not meet the specifications listed in the *Specifications*, you can send the probe to Tektronix for calibration and repair. (See page 41, *Preparation for Shipment*.)

Error Condition

The LEDs on the probe alert you to error or status conditions affecting the probe. When the probe is functioning correctly, there is a quick flash of the LEDs on the probe just after connecting to the oscilloscope. If the probe LEDs flash or otherwise appear to be malfunctioning, an error condition may exist. Disconnect the probe and reconnect it to another channel to isolate the problem. If the symptoms persist with the probe, call your Tektronix representative for service.

Replaceable Parts

The following parts may need to be replaced due to normal wear and damage. When you replace these components, secure the probe in a small vise or positioner to simplify the procedure.

Table 8: TriMode probes replaceable parts

Description	Replacement part number
P7600 Series probe body bullet contacts	020-3105-xx, kit of 4
P76TA adapter bullet contacts	013-0359-xx, kit of 4
P75PST & P75TLRST solder tip wires	020-2754-xx, Wire Replacement Kit, includes one bobbin each: 4 mil wire, 8 mil wire, and SAC305 solder

See the user manual for a list of the accessories that are available for your probe.

Table 9: Required equipment

Description	Minimum requirement	Recommended example ¹
P7600 Series probe body bullet removal tool		003-1934-xx
P76TA adapter bullet removal tool		003-1896-xx
Probe positioner or bench vise	Able to hold probe	PPM203B or PPM100
Magnifying glass or microscope	Free standing to allow hands-free use	
Tweezers	General purpose	

¹ Nine-digit part numbers (xxx-xxxx-xx) are Tektronix part numbers.

Replacing the Bullet Contacts

The bullet contacts in the head of the P7600 Series TriMode Probes and the P76TA adapter should be replaced every 200 insertion cycles. The bullet contacts and removal tool differ in size between the two and cannot be interchanged. The P76TA components are larger, but the procedures are similar for both the probe and adapter.

To replace the bullets, use the bullets and bullet removal tool listed in the tables above, and follow the steps below.

Remove.

1. Squeeze the tool plunger to extend the holder tangs.
2. Insert the tool into the probe body or adapter so that the holder tangs surround one of the bullets.
3. Release the plunger to secure the holder tangs on the bullet.
4. Gently pull the tool outward to remove the bullet.
5. Repeat for the other bullet.



CAUTION. *If you cannot extract the bullets with the bullet removal tool, use fine needle-nosed pliers and a magnifying glass or microscope. Be careful not to damage the probe adapter with the pliers.*

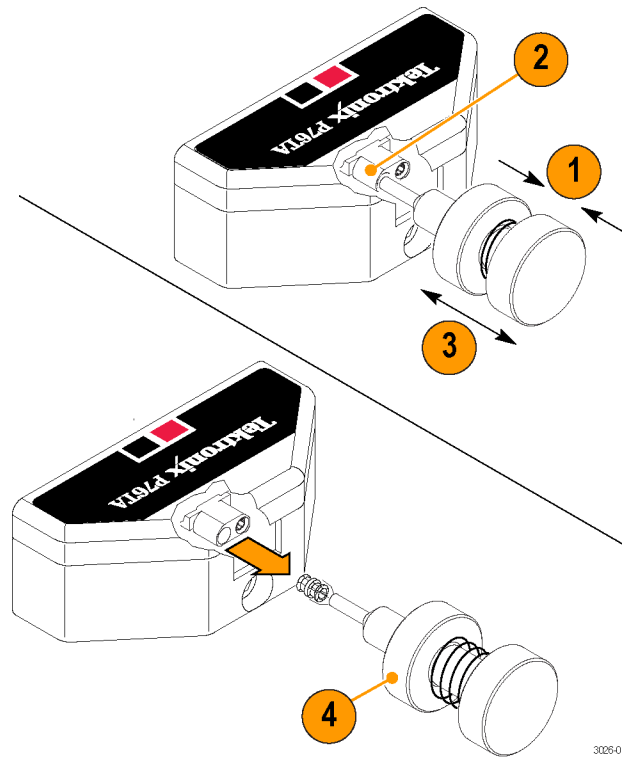

3026-012

Figure 29: Removing the bullets

Install. When both bullets have been removed, install new bullets by doing the following:

1. Squeeze the tool plunger to extend the holder tangs.
2. Insert a new bullet into the tool so that the holder tangs surround the bullet.
3. Release the plunger to secure the holder tangs on the bullet.
4. Insert the tool into the probe body or adapter and seat the bullet in the recess.
5. Squeeze the tool plunger to release the bullet.
6. Gently pull the tool out of the probe or adapter.
7. Repeat for the other bullet.
8. Test that the bullets are installed correctly by connecting and then removing the P76TA adapter from the probe, or an accessory solder tip to and from the probe adapter. Inspect the probe or adapter and verify that the bullets remain seated in the probe or adapter (where you installed them).

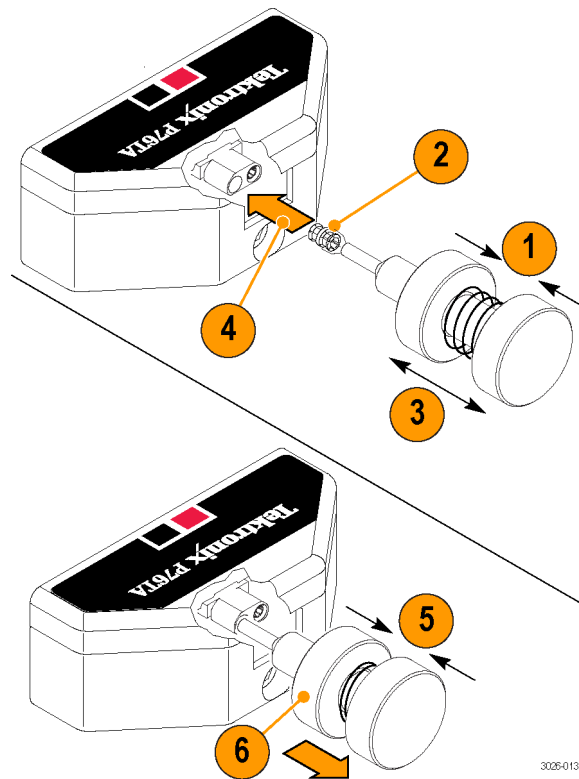

Figure 30: Installing the bullets

P75PST & P75TLRST Solder Tip Wires

The solder vias on the circuit board at the end of the P75PST and P75TLRST solder tips are small (0.012 in.), and require small wires to attach to your circuit. (Use the 4-mil and 8-mil wires included with the Wire Replacement kit to make the connections.) Because of the small dimensions, the solder tips have a limited number of solder cycles that the vias can withstand before the Solder Tips become unusable. If you expect to make frequent soldering changes, consider using the optional TriMode Resistor solder tips. The resistors that extend off of these tips can accept a higher number of solder cycles and can be replaced when necessary.

NOTE. *Axial-leaded tip resistors (included in the TriMode resistor replacement kit, Tektronix part number 020-2937-xx), should not be used in place of wires with the P75PST and P75TLRST probe tips unless the surface-mount, SMD0402 resistors are also changed. The total probe tip resistance for the P7500 Series solder tips is designed to be 175 Ω .*



CAUTION. *To prevent damage to the circuit board or circuit board connections due to accidental movement of the probe and soldered leads, we recommend that you secure the tip to the circuit board using the adhesive tip tape provided in your accessory kit. You can also use other materials such as Kapton tape or hot glue.*

To avoid damage to the tip or the circuit under test, avoid applying excessive heat from the soldering iron. Use a low wattage, temperature-controlled soldering iron and appropriately sized soldering iron tip.

To prolong the life of your solder tips, consider the following points before you use the solder tips.

Consider the types of measurements that you plan to take. If you are going to take a few measurements at one location and then move to another, you may be able to use longer wires. Longer wires may degrade your measurement slightly (which may not matter), but the wires can then be cut or de-soldered at your circuit and reused, rather than subjecting the solder tip to a desolder/solder cycle.

At critical test points such as circuit outputs, you might need to keep the wires as short as possible. If possible, use the solder tip dimensions shown in the *Specifications* section to lay out a matching footprint on your circuit board.

Use the following precautions when you solder the tips:

- For best soldering results, use a microscope to examine the quality of the solder joints.
- Use a low-wattage, temperature-controlled soldering iron and a small mass soldering iron tip. The soldering iron temperature should be set as low as possible, while still providing a reliable solder joint.
- Use SAC305 solder (included with the wire replacement kit) to attach the tip wires to the circuit under test.
- When replacing tip wires or axial-lead resistors, solder wick can be used to remove the excess solder from the probe tip circuit board via holes. Be careful not to overheat the via and damage the board.
- The attachment wires should be bent symmetrically to vary the interconnect spacing. Use care when you solder a tip to a circuit under test to avoid inadvertently de-soldering either the attachment wires or the damping resistor.
- For optimum performance and signal integrity, keep the lead length between the DUT (Device Under Test) and the tip as short as possible, and the lead lengths the same length.

Preparation for Shipment

If the original packaging is unfit for use or not available, use the following packaging guidelines:

1. Use a corrugated cardboard shipping carton having inside dimensions at least one inch greater than the probe dimensions. The box should have a carton test strength of at least 200 pounds.
2. Put the probe into an antistatic bag or wrap to protect it from dampness.
3. Place the probe into the box and stabilize it with lightweight packing material.
4. Seal the carton with shipping tape.
5. Refer to *Contacting Tektronix* on the copyright page of this manual for the shipping address.

Index

A

Autoset, 12

C

Channel isolation, 26

Characteristics

 Mechanical, 31

 nominal, 34

CMRR, 24

 assessing CMRR error, 25

Coaxial adapters, 14

D

Differential measurements, 24

Differential-Mode Rejection

 Ratio, 25

DUT connections, 20

E

Error condition, 35

F

Frequency response, 31

I

Input impedance, 14

Input signal dynamic range, 9

Input voltage, 8

O

Offset voltage, 10, 12

Operating voltage window, 9

P

P75PST & P75TLRST

 solder tip wires, 39

P75PST and P75TLRST

 TriMode solder tips, 17

P76TA, 15

 replacing the bullet

 contacts, 36

Preparation for Shipment, 41

Probe components, 1

Probe input architecture, 5

Probing techniques, 17

R

Replaceable parts, 35

Rise time, 31

S

Safety Summary, iv

Scale factor, 16

Single-ended measurements, 23

Specifications

 typical, 29

 warranted, 27

T

Termination voltage, 11, 13

TriMode operation, 6

U

User service, 35