

Keysight Technologies  
Switching Solutions for  
Multi-Lane BERT Testing

Application Note



Unlocking Measurement Insights

## Introduction

Many high-speed digital interfaces use multiple lanes to achieve the throughput requirements for their systems. With this brings challenges for validation and characterization because of connection requirements, including single-ended as well as differential testing and more lines than BERT (bit error rate tester) channels available. A Keysight Technologies, Inc. switching solution can resolve these challenges with high reliability at an affordable cost. This application note addresses the use of switching solutions, degradations that might be encountered, and the methods to overcome them.

The focus of this application note will be on the testing of optical transceivers. To test a 4-lane optical transceiver with a BERT, you must connect and test each lane one after the other, due to limited test ports. Figure 1 shows a typical setup for optical transceiver testing using a BERT. To test 4 lanes simultaneously, an investment in multiple sources and detectors would be required but this is not cost effective solution.

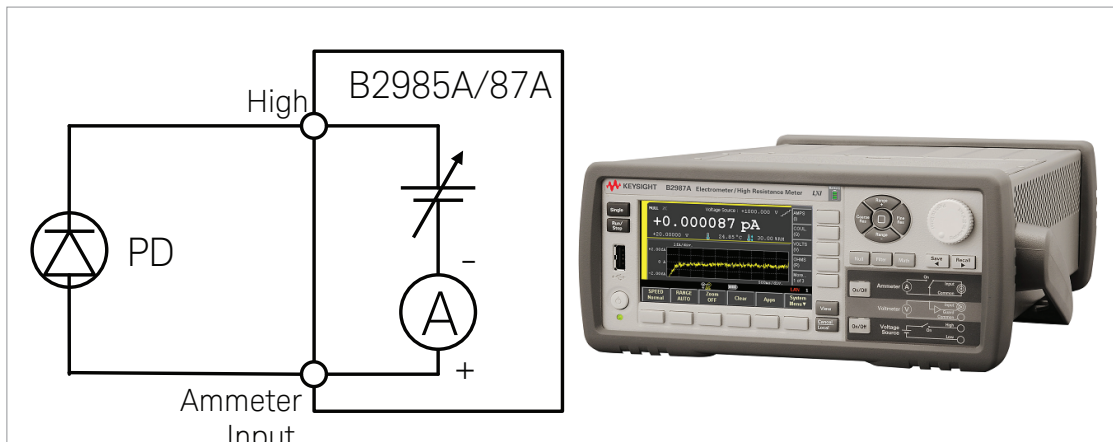

Figure 1. Optical transceiver testing using a BERT

By adding switches, you can create a switching network to eliminate the need for reconnection. The setup in Figure 2 shows how you can seamlessly switch between data lanes without physically reconnecting the cables and connectors, thus reducing the reconnection time and cost of test.

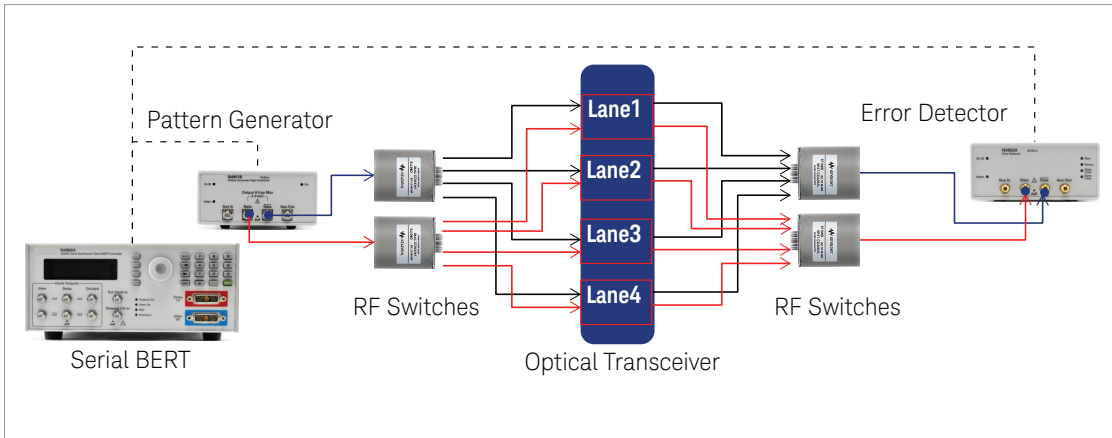

Figure 2. Switching network eliminates the need for reconnection

The setup in Figure 2 shows that the switches are connected to a path one at a time. In reality, all 4 lanes may have signals flowing concurrently. Therefore, crosstalk between lanes will need to be taken into consideration during testing. In order to simulate real-world multi-lane networks, power splitters were used to replace the switches at the input end of the optical transceiver, see Figure 3.

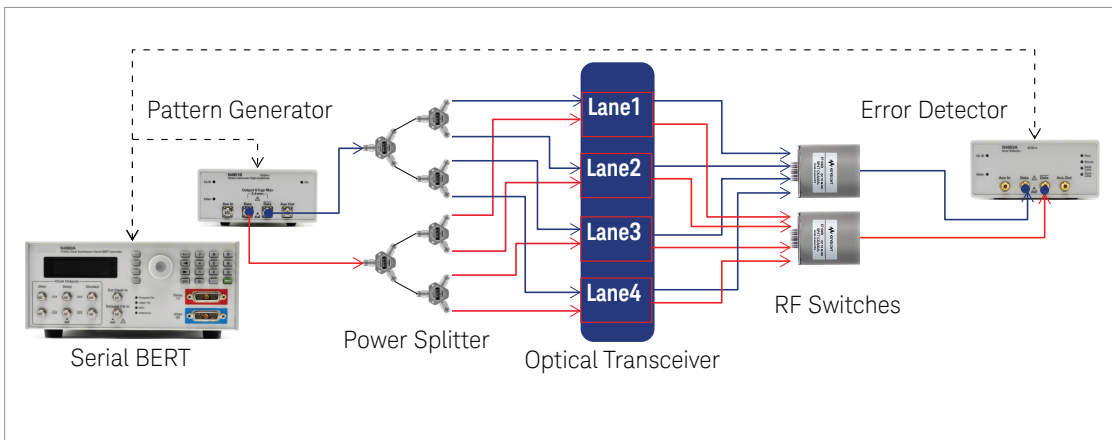

Figure 3. Power splitters replace the switches to simulate real-world multi-lane networks

## Test Validation

Setup in figure 3 had been practically tested and validated the use of splitters and switches to create a multi-lane BERT testing network. Below are the instruments and accessories used in this setup.

1. Keysight N4960A serial BERT
2. Keysight N4951B-D32 pattern generator
3. Keysight N4952A-E17 error detector
4. Keysight 11667C power splitter
5. Keysight 87104D RF & microwave switch

Test case 1: Directly feed the signal from the pattern generator to the optical transceiver and measure the output of the optical transceiver with an error detector.

Test case 2: Split the signal from pattern generator with a 2-tier power splitter setup before feeding the signal into an optical transceiver, then route the output signal of the optical transceiver via the switches before measuring with the error detector.

## Results

Test case 2 (eye diagram of -10% mask margin) is worse compared to case 1 (eye diagram of 21% mask margin).

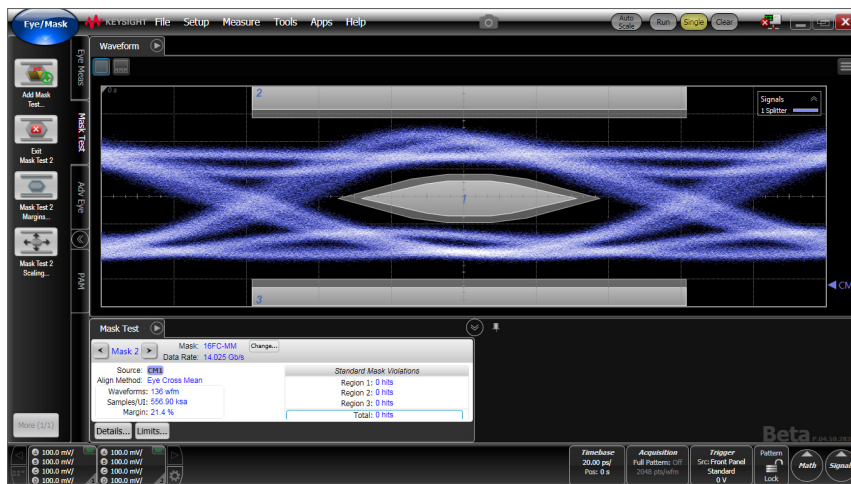

Figure 3. Test Case 1: Direct measurement without switching network (21% mask margin)

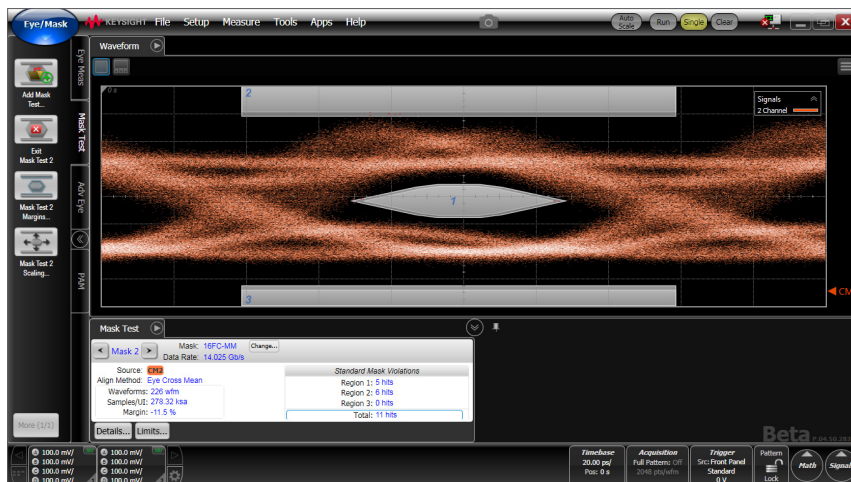

Figure 4. Test Case 2: Measurement via a 2-tier power splitters and RF switches (-10% mask margin)

## Design Improvements

Two opportunities were identified to improve the measurement:

1. Increase the signal voltage of the pattern generator

The default voltage value for the Keysight N4951B-D32 pattern generator is 0.5 V. The insertion loss of the 2-tier power splitter is around 13 dB. After passing through the 2-tier power splitter, the signal voltage will drop to around 110 mV. Low signal voltage level will degrade the eye diagram measurement. Even with the maximum setting of 1.5 V after the 2-tier power splitters, the voltage will drop to 300 mV, which is still too low to generate a good eye diagram measurement. Therefore, by replacing the Keysight N4961B-D32 with the Keysight N4951B-H15 high voltage output pattern generator with a 3 V signal, the voltage measured by the error detector is still more than 600 mV, even after the loss via the 2-tier power splitters.

2. Improve the impedance mismatch at the input of device-under-test (DUT), in this case the optical transceiver (including the test fixture, module compliance board).

If the termination/impedance of the DUT is not 50 Ohm (for single ended) or 100 Ohm (for differential), reflection will occur. Power splitters are bi-directional; reflections at one port will also affect the signal at the other end. Knowing this, the quality of the signal that reaches the DUT will decrease significantly. In order to improve the signal integrity, the 8493C 6 dB fixed attenuator is used to attenuate the reflected signals caused by the impedance mismatch.

## Improved Results

By incorporating the two improvements above, a mask margin of 16% is very close to the direct measurement (without power splitters and RF switches) of 21%.

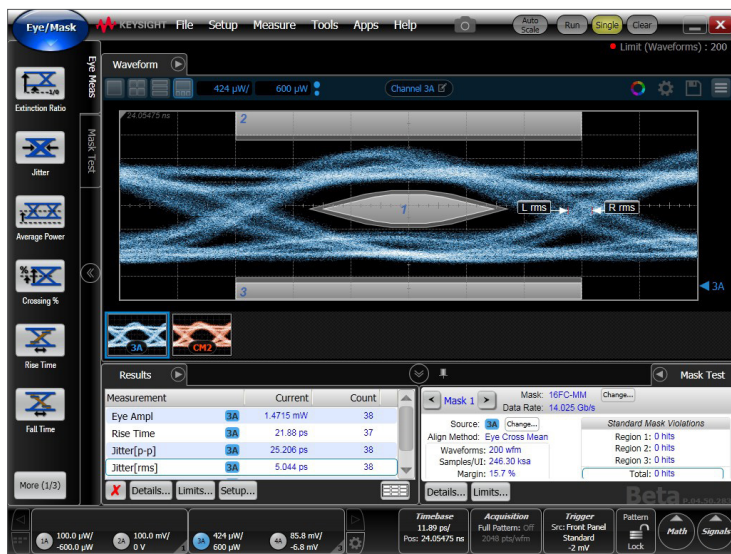

Figure 5. Result: Mask margin improved to 16% after incorporating the 2 improvements above

## Conclusion

A switching network consisting of power splitters and RF switches will improve BERT testing throughput. Pattern generator signal voltage output is crucial to ensure that the signal level reaching the DUT is sufficiently high enough for the error detector to output an accurate eye diagram. Attenuators should be used to improve the mismatch at the input of the DUT to reduce reflections.

## Evolving Since 1939

Our unique combination of hardware, software, services, and people can help you reach your next breakthrough. We are unlocking the future of technology.

From Hewlett-Packard to Agilent to Keysight.



For more information on Keysight Technologies' products, applications or services, please contact your local Keysight office. The complete list is available at: [www.keysight.com/find/contactus](http://www.keysight.com/find/contactus)

### Americas

Canada	(877) 894 4414
Brazil	55 11 3351 7010
Mexico	001 800 254 2440
United States	(800) 829 4444

### Asia Pacific

Australia	1 800 629 485
China	800 810 0189
Hong Kong	800 938 693
India	1 800 11 2626
Japan	0120 (421) 345
Korea	080 769 0800
Malaysia	1 800 888 848
Singapore	1 800 375 8100
Taiwan	0800 047 866
Other AP Countries	(65) 6375 8100

### Europe & Middle East

Austria	0800 001122
Belgium	0800 58580
Finland	0800 523252
France	0805 980333
Germany	0800 6270999
Ireland	1800 832700
Israel	1 809 343051
Italy	800 599100
Luxembourg	+32 800 58580
Netherlands	0800 0233200
Russia	8800 5009286
Spain	800 000154
Sweden	0200 882255
Switzerland	0800 805353
	Opt. 1 (DE)
	Opt. 2 (FR)
	Opt. 3 (IT)
United Kingdom	0800 0260637

For other unlisted countries: [www.keysight.com/find/contactus](http://www.keysight.com/find/contactus) (BP-9-7-17)



[www.keysight.com/go/quality](http://www.keysight.com/go/quality)  
Keysight Technologies, Inc.  
DEKRA Certified ISO 9001:2015  
Quality Management System

### myKeysight

#### myKeysight

[www.keysight.com/find/mykeysight](http://www.keysight.com/find/mykeysight)

A personalized view into the information most relevant to you.

[http://www.keysight.com/find/emt\\_product\\_registration](http://www.keysight.com/find/emt_product_registration)

Register your products to get up-to-date product information and find warranty information.



#### Keysight Services

[www.keysight.com/find/service](http://www.keysight.com/find/service)

Keysight Services can help from acquisition to renewal across your instrument's lifecycle. Our comprehensive service offerings—one-stop calibration, repair, asset management, technology refresh, consulting, training and more—helps you improve product quality and lower costs.



#### Keysight Assurance Plans

[www.keysight.com/find/AssurancePlans](http://www.keysight.com/find/AssurancePlans)

Up to ten years of protection and no budgetary surprises to ensure your instruments are operating to specification, so you can rely on accurate measurements.

#### Keysight Channel Partners

[www.keysight.com/find/channelpartners](http://www.keysight.com/find/channelpartners)

Get the best of both worlds: Keysight's measurement expertise and product breadth, combined with channel partner convenience.

[www.keysight.com/find/mta](http://www.keysight.com/find/mta)



Unlocking Measurement Insights

This information is subject to change without notice.  
© Keysight Technologies, 2017  
Published in USA, December 1, 2017  
5992-1107EN  
[www.keysight.com](http://www.keysight.com)