

Keysight 8710x Low PIM Coaxial Multiport Switches

Operating and
Service Manual

Notices

Copyright Notice

© Keysight Technologies 2014 - 2019

No part of this manual may be reproduced in any form or by any means (including electronic storage and retrieval or translation into a foreign language) without prior agreement and written consent from Keysight Technologies as governed by United States and international copyright laws.

Manual Part Number

87104-80017

Edition

Edition 3, March 14, 2019

Printed in:

Printed in Malaysia

Published by:

Keysight Technologies
Bayan Lepas Free Industrial Zone,
11900 Penang, Malaysia

Technology Licenses

The hardware and/or software described in this document are furnished under a license and may be used or copied only in accordance with the terms of such license.

Declaration of Conformity

Declarations of Conformity for this product and for other Keysight products may be downloaded from the Web. Go to <http://www.keysight.com/go/conformity>. You can then search by product number to find the latest Declaration of Conformity.

U.S. Government Rights

The Software is "commercial computer software," as defined by Federal Acquisition Regulation ("FAR") 2.101. Pursuant to FAR 12.212 and 27.405-3 and Department of Defense FAR Supplement ("DFARS") 227.7202, the U.S. government acquires commercial computer software under the same terms by which the software is customarily provided to the public. Accordingly, Keysight provides the Software to U.S. government customers under its standard commercial license, which is embodied in its End User License Agreement (EULA), a copy of which can be found at <http://www.keysight.com/find/sweula>. The license set forth in the EULA represents the exclusive authority by which the U.S. government may use, modify, distribute, or disclose the Software. The EULA and the license set forth therein, does not require or permit, among other things, that Keysight: (1) Furnish technical information related to commercial computer software or commercial computer software documentation that is not customarily provided to the public; or (2) Relinquish to, or otherwise provide, the government rights in excess of these rights customarily provided to the public to use, modify, reproduce, release, perform, display, or disclose commercial computer software or commercial computer software documentation. No additional government requirements beyond those set forth in the EULA shall apply, except to the extent that those terms, rights, or licenses are explicitly required from all providers of commercial computer software pursuant to the FAR and the DFARS and are set forth specifically in writing elsewhere in the EULA. Keysight shall be under no obligation to update, revise or otherwise modify the Software. With respect to any technical data as defined by FAR 2.101, pursuant to FAR 12.211 and 27.404.2 and DFARS 227.7102, the U.S. government acquires no greater than Limited Rights as defined in FAR 27.401 or DFAR 227.7103-5 (c), as applicable in any technical data.

Warranty

THE MATERIAL CONTAINED IN THIS DOCUMENT IS PROVIDED "AS IS," AND IS SUBJECT TO BEING CHANGED, WITHOUT NOTICE, IN FUTURE EDITIONS. FURTHER, TO THE MAXIMUM EXTENT PERMITTED BY APPLICABLE LAW, KEYSIGHT DISCLAIMS ALL WARRANTIES, EITHER EXPRESS OR IMPLIED, WITH REGARD TO THIS MANUAL AND ANY INFORMATION CONTAINED HEREIN, INCLUDING BUT NOT LIMITED TO THE IMPLIED WARRANTIES OF MERCHANTABILITY AND FITNESS FOR A PARTICULAR PURPOSE. KEYSIGHT SHALL NOT BE LIABLE FOR ERRORS OR FOR INCIDENTAL OR CONSEQUENTIAL DAMAGES IN CONNECTION WITH THE FURNISHING, USE, OR PERFORMANCE OF THIS DOCUMENT OR OF ANY INFORMATION CONTAINED HEREIN. SHOULD KEYSIGHT AND THE USER HAVE A SEPARATE WRITTEN AGREEMENT WITH WARRANTY TERMS COVERING THE MATERIAL IN THIS DOCUMENT THAT CONFLICT WITH THESE TERMS, THE WARRANTY TERMS IN THE SEPARATE AGREEMENT SHALL CONTROL.

Safety Information

CAUTION

A CAUTION notice denotes a hazard. It calls attention to an operating procedure, practice, or the like that, if not correctly performed or adhered to, could result in damage to the product or loss of important data. Do not proceed beyond a CAUTION notice until the indicated conditions are fully understood and met.

WARNING

A WARNING notice denotes a hazard. It calls attention to an operating procedure, practice, or the like that, if not correctly performed or adhered to, could result in personal injury or death. Do not proceed beyond a WARNING notice until the indicated conditions are fully understood and met.

Waste Electrical and Electronic Equipment (WEEE) Directive

This instrument complies with the WEEE Directive marking requirement. This affixed product label indicates that you must not discard this electrical or electronic product in domestic household waste.

Product category:

With reference to the equipment types in the WEEE directive Annex 1, this instrument is classified as a “Monitoring and Control Instrument” product.

The affixed product label is as shown below.



Do not dispose in domestic household waste.

To return this unwanted instrument, contact your nearest Keysight Service Center, or visit <http://about.keysight.com/en/companyinfo/environment/takeback.shtml> for more information.

Sales and Technical Support

To contact Keysight for sales and technical support, refer to the support links on the following Keysight websites:

- www.keysight.com/find/switches
(product-specific information and support, software and documentation updates)
- www.keysight.com/find/assist
(worldwide contact information for repair and service)

THIS PAGE HAS BEEN INTENTIONALLY LEFT BLANK.

Table of Contents

Waste Electrical and Electronic Equipment (WEEE) Directive	3
Product category:	3
Sales and Technical Support	3
List of Figures	7
List of Tables	9
1 Introduction	
General Information	12
Key Features	13
2 Switch Configuration	
Driving the Switch	16
Standard Drive	17
TTL Drive (Option T24)	18
Electronic Position Indicators	19
3 Specifications	
General Specifications	22
Supplemental specifications (cold switching)	22
RF Specifications	24
Indicator Specifications	25
Switch Drive Specifications	26
TTL drive (option T24)	26
Environmental Specifications	27
Physical Specifications	28
4 Installation and Verification	
Installation	30
Initial inspection	30
Operating and Service Instructions	31
Operator's check	31
Performance test	32
Service instructions	32

THIS PAGE HAS BEEN INTENTIONALLY LEFT BLANK.

List of Figures

- Figure 1-1 Keysight 8710x low PIM coaxial multiport switches 12
- Figure 2-1 Drive connection diagrams for Option 161 and Option 100 16
- Figure 2-2 Pin configuration for indicator function 19
- Figure 3-1 Maximum incident power (cold switching) vs. frequency 22
- Figure 3-2 Power derating factor vs. VSWR 23
- Figure 3-3 TTL control voltage states (Option T24) 26
- Figure 3-4 Dimensions of Keysight 8710x low PIM coaxial multiport switches .. 28
- Figure 4-1 Connection to perform quick check 31

THIS PAGE HAS BEEN INTENTIONALLY LEFT BLANK.

List of Tables

- Table 1-1 List of Keysight 8710x low PIM coaxial multiport switches 12
- Table 3-1 General specifications 22
- Table 3-2 RF specifications for 87104P/Q and 87106P/Q 24
- Table 3-3 RF specifications for 87104R and 87106R 24
- Table 3-4 Indicator specifications 25
- Table 3-5 Switch drive specifications 26
- Table 3-6 Switch drive specifications for TTL drive (option 24) 26
- Table 3-7 Environmental specifications 27
- Table 3-8 Physical specifications 28
- Table 4-1 Replacement units 33

THIS PAGE HAS BEEN INTENTIONALLY LEFT BLANK.

1 Introduction

General Information 12

Key Features 13

This chapter provides you the overview of Keysight 8710x low PIM coaxial multiport switches.

General Information

Keysight 87104P/Q/R SP4T and 87106P/Q/R SP6T terminated switches provide the life and reliability required for automated test and measurement and signal monitoring and routing applications. These switches can be used in various applications as they are available in multiple frequency ranges, up to 26.5 GHz.



Figure 1-1 Keysight 8710x low PIM coaxial multiport switches

Innovative design and careful process control create switches that meet the requirements for highly repeatable switching elements in test instruments and switching interfaces. The exceptional 0.03 dB insertion loss repeatability is warranted for 3 million cycles at 25 °C. This reduces sources of random errors in the measurement path and improves measurement uncertainty. Switch life is a critical consideration in production test systems, satellite and antenna monitoring systems, and test instrumentation. The longevity of these switches increases system uptime and lowers the cost of ownership by reducing calibration cycles and switch maintenance.

Table 1-1 List of Keysight 8710x low PIM coaxial multiport switches

Model number	Frequency range	Configuration
87104P	DC to 4 GHz	SP4T
87104Q	DC to 20 GHz	SP4T
87104R	DC to 26.5 GHz	SP4T
87106P	DC to 4 GHz	SP4T
87106Q	DC to 20 GHz	SP4T
87106R	DC to 26.5 GHz	SP4T

Key Features

- SP4T and SP6T configurations
- Magnetic latching
- Guaranteed repeatability of 0.03 dB up to 3 million cycles, ensuring accurate system measurements and reducing calibration intervals
- Excellent isolation, typically > 90 dB at 26.5 GHz
- PIM level (typical) of -165 dBc
- Opto-electronic indicators and interrupts
- Terminated ports

THIS PAGE HAS BEEN INTENTIONALLY LEFT BLANK.

2 Switch Configuration

Driving the Switch	16
Standard Drive	17
TTL Drive (Option T24)	18
Electronic Position Indicators	19

This chapter provides you information on how to drive the switches using standard drive and TTL drive. Also included is the configuration to utilize the function of the position indicator.

Driving the Switch

Each RF path can be closed by applying ground (TTL “High” for Option T24) to the corresponding “drive” pin. In general, all other RF paths are simultaneously opened by internal logic. See [Figure 2-1](#) for drive connection diagrams.

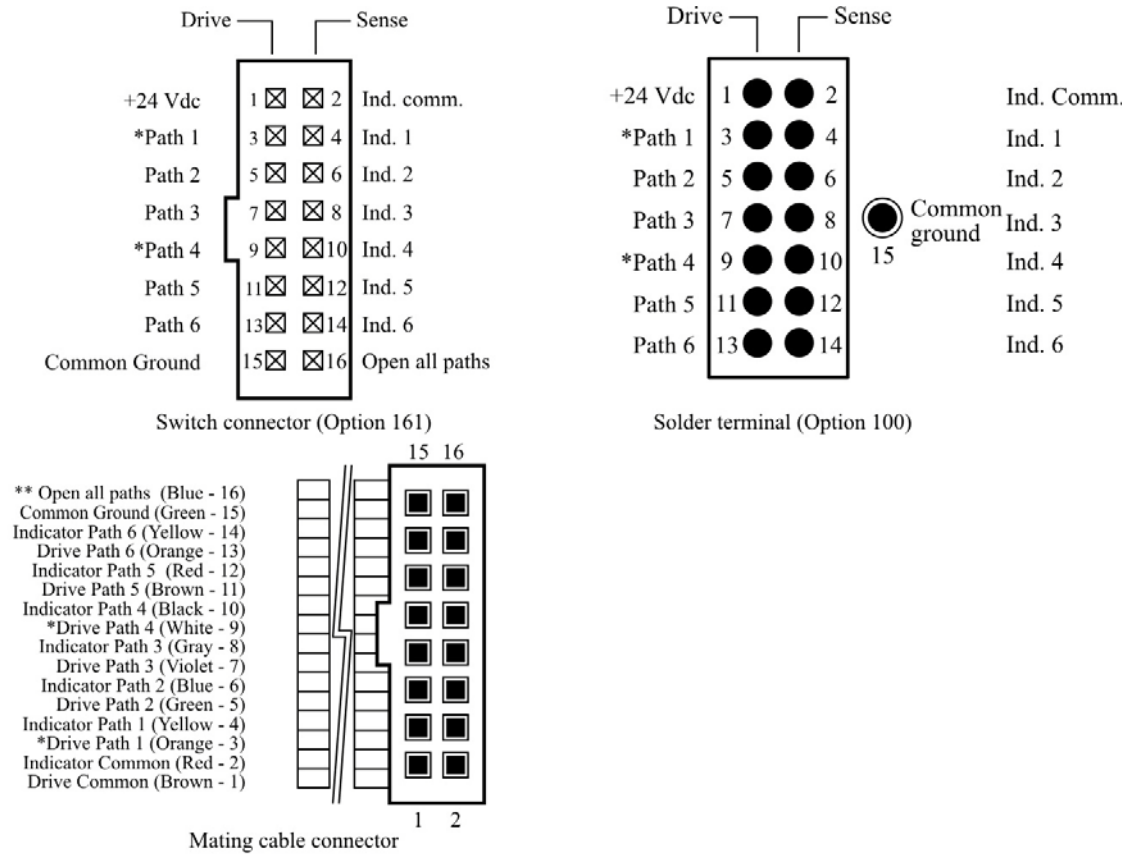

* Path1 and path 4 are not connected for 87104A/B/0C/D
 ** *Open all paths pin is not available for option 100

Figure 2-1 Drive connection diagrams for Option 161 and Option 100

The default operation of the switches is break-before-make. Make-before-break switching can be accomplished by simultaneously selecting the “drive” pins for old RF path and new RF path. Once the new RF path is closed (15 ms), de-select the old RF path “drive” pin while leaving the new RF path “drive” pin selected. The switch circuitry will automatically open the old RF path while leaving the new RF path engaged.

Standard Drive

- 1 Connect pin 1 to supply voltage (+20 Vdc to +32 Vdc) and pin 15 to ground.

NOTE

Pin 15 must always be connected to ground to enable the electronic position-indicating circuitry and drive logic circuitry.

CAUTION

If pin 15 is not connected to power supply ground, catastrophic failure will occur.

- 2 Select (close) desired RF path by applying ground to the corresponding “drive” pin; for example ground pin 3 to close RF path 1.

NOTE

After the RF path is switched and latched, the drive current is interrupted by the electronic position-sensing circuitry. Pulsed control is not necessary, but if implemented, the pulse width must be 15 ms minimum to ensure the switch is fully latched.

- 3 To select another RF path, ensure that all unwanted RF path “drive” pins are disconnected from ground (to prevent multiple RF path engagement). Ground the “drive” pin which corresponds to the desired RF path.
- 4 To open all RF paths, ensure that all RF path “drive” pins are disconnected from ground. Then, connect pin 16 to ground. This feature is not available in option 100.

TTL Drive (Option T24)

- 1 Connect pin 1 to supply voltage (+20 Vdc to +32 Vdc) and pin 15 to ground.

NOTE

Pin 15 must always be connected to ground to enable the electronic position-indicating circuitry and drive logic circuitry.

In addition to the quiescent current supplying the electronic position-sensing circuitry, the drive current flows out of pin 15 (during switching) on TTL drive switches (option T24).

CAUTION

If pin 15 is not connected to power supply ground, catastrophic failure will occur.

- 2 Select (close) desired RF path by applying ground to the corresponding “drive” pin; for example apply TTL “High” to pin 3 to close RF path 1.

NOTE

After the RF path is switched and latched, the drive current is interrupted by the electronic position-sensing circuitry. Pulsed control is not necessary, but if implemented, the pulse width must be 15 ms minimum to ensure the switch is fully latched.

- 3 To select another RF path, ensure that all unwanted RF path “drive” pins are at TTL “Low” (to prevent multiple RF path engagement). Apply TTL “High” to the “drive” pin which corresponds to the desired RF path.
- 4 To open all RF paths, ensure that all RF path “drive” pins are at TTL “Low”. Then, apply TTL “High” to pin. This feature is not available in option 100.

Electronic Position Indicators

The electronic position indicators consist of optically isolated, solid state relays which are driven by photo-electric sensors coupled to the mechanical position of the RF path's moving elements (see Figure 2-2). The circuitry consists of a common which can be connected to an output corresponding to each RF path. If multiple RF paths are engaged, the position indicator corresponding to each closed RF path will be connected to common. The solid state relays are configured for AC and/or DC operation. See "Indicator Specifications" on page 25. The electronic position indicators require that the supply (20 to 32 VDC) be connected to pin 1 and ground connected to pin 15.

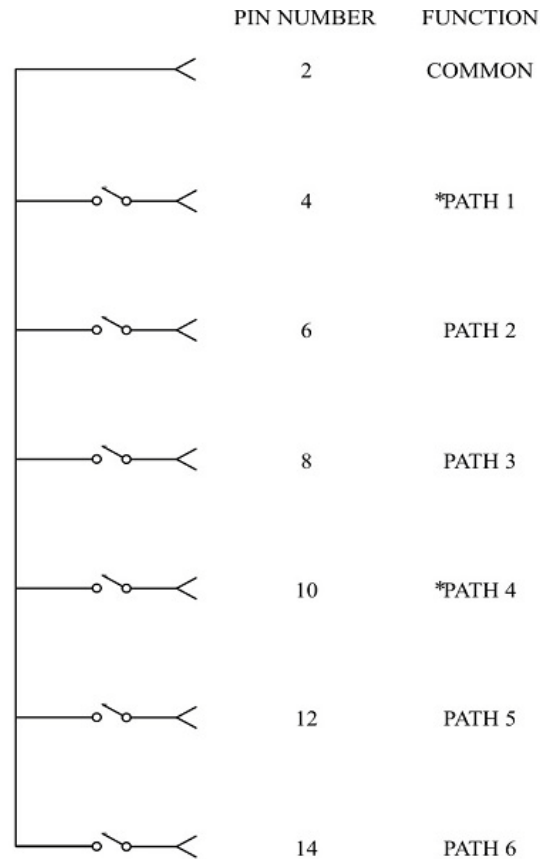

*Paths 1 and 4 are not connected for 87104P/Q/R

Figure 2-2 Pin configuration for indicator function

THIS PAGE HAS BEEN INTENTIONALLY LEFT BLANK.

3 Specifications

General Specifications	22
RF Specifications	24
Indicator Specifications	25
Switch Drive Specifications	26
Environmental Specifications	27
Physical Specifications	28

This chapter provides the specifications of the switches.

Specifications refer to the performance standards or limits against which the coaxial multipoint switches are tested.

Typical characteristics are included for additional information only and they are not specifications. These are denoted as “typical”, “nominal”, or “approximate” and are printed in italics.

General Specifications

Table 3-1 General specifications

Keysight model number	87104P/Q/R and 87106P/Q/R
Maximum power rating	1 watt average into 50 Ω internal loads
Hot switching	1 watt CW 50 W peak, 10 μ s max pulse width, not to exceed 1 W average.
Cold switching	See Supplemental specifications (cold switching)
Life	3,000,000 cycles minimum
Switching speed	15 ms maximum

Supplemental specifications (cold switching)

[Figure 3-1](#) illustrates the maximum incident CW power (cold switching) from 100 MHz to 26.5 GHz. The reference conditions are as below:

- Cold switching only (NO hot switching)
- Ambient temperature of 75 °C or less
- Sea level (0.88 derating at 15,000 feet)
- Low VSWR < 1.2 (See [Figure 3-2](#) for derating above 1.2 VSWR)

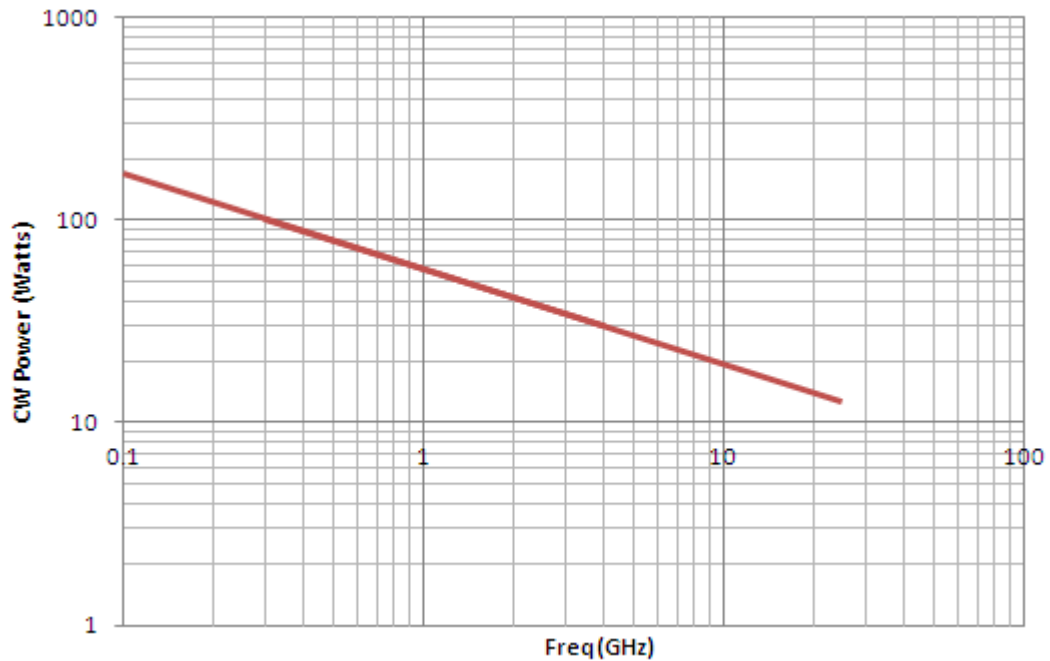

Figure 3-1 Maximum incident power (cold switching) vs. frequency

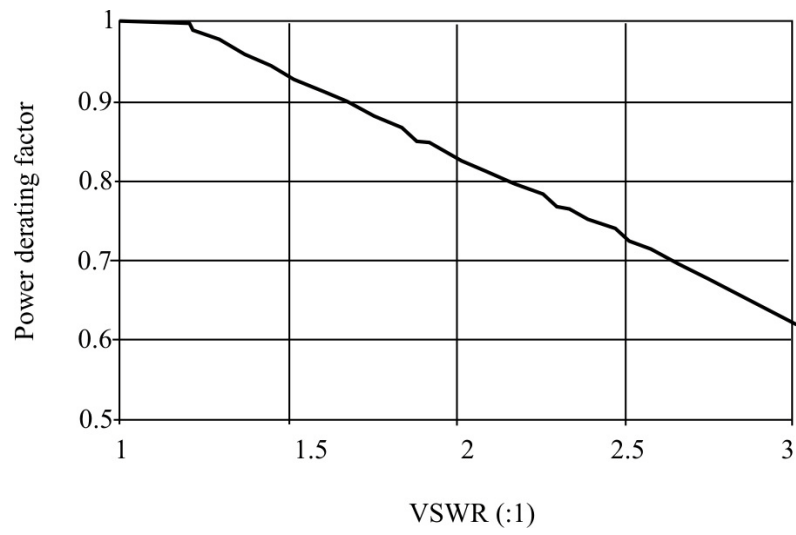

Figure 3-2 Power derating factor vs. VSWR

RF Specifications

Table 3-2 RF specifications for 87104P/Q and 87106P/Q

Keysight model number	87104P and 87106P	87104Q and 87106Q
Frequency range	DC to 4 GHz	DC to 20 GHz
Insertion loss (dB)	$0.015f^{[a]} + 0.3$	$0.015f^{[a]} + 0.3$
Isolation (dB)	> 100	> 100 (DC to 12 GHz) > 80 (12 to 15 GHz) > 70 (15 to 20 GHz)
SWR	< 1.20	< 1.20 (DC to 4 GHz) < 1.35 (4 to 12.4 GHz) < 1.45 (12.4 to 20 GHz)
Repeatability ^[b] (dB)	< 0.03	< 0.03
Characteristics	50 Ω , terminated	50 Ω , terminated
Connectors	SMA (f)	SMA (f)

[a] f = frequency in GHz

[b] Up to 3 million cycles, measured at 25 °C

Table 3-3 RF specifications for 87104R and 87106R

Keysight model number	87104R and 87106R
Frequency range	DC to 26.5 GHz
Insertion loss (dB)	$0.015f^{[a]} + 0.3$
Isolation (dB)	> 100 (DC to 12 GHz) > 80 (12 to 15 GHz) > 70 (15 to 20 GHz) > 65 (20 to 26.5 GHz)
SWR	< 1.20 (DC to 4 GHz) < 1.35 (4 to 12.4 GHz) < 1.45 (12.4 to 20 GHz) < 1.70 (20 to 26.5 GHz)
Repeatability ^[b] (dB)	< 0.03
Characteristics	50 Ω , terminated
Connectors	SMA (f)

[a] f = frequency in GHz

[b] Up to 3 million cycles, measured at 25 °C

Indicator Specifications

Table 3-4 Indicator specifications

Keysight model number	87104P/Q/R and 87106P/Q/R
Maximum withstand voltage	60 V
Maximum current capacity	150 mA
Maximum "ON" resistance	2.5 Ω
Maximum "OFF" resistance	10 G Ω

Switch Drive Specifications

Table 3-5 Switch drive specifications

Parameter	Min	Nom	Max	Unit
Supply voltage, Vcc	20	24	32	V
Supply current, Icc ^[a]		200 ^[b]		mA
Supply current (quiescent)	25		50	mA

[a] Switching condition: pulse width ≥ 15 ms (Vcc = 24 VDC).

[b] Closing one RF path requires 200 mA. Add 200 mA for each additional RF path closed or opened. Using all RF paths open (selecting pin 16) requires 200 mA per RF path reset with Vcc = 24 VDC.

TTL drive (option T24)

Table 3-6 Switch drive specifications for TTL drive (option 24)

Parameter	Min	Nom	Max	Unit
High level input	3		7	V
Low level input			0.8	V
Max high input current ^[a]		1	1.4	mA

[a] Vcc = Max. Vinut = 3.85 VDC.

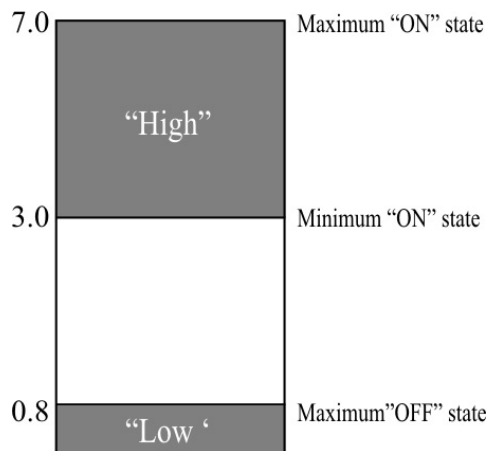

Figure 3-3 TTL control voltage states (Option T24)

Environmental Specifications

The N1923/4A low PIM coaxial multiport switches are designed to fully comply with Keysight's product operating environmental specifications.

Table 3-7 Environmental specifications

Parameter	Specification
Temperature	
- Operating	-25 °C to 75 °C
- Storage	-55 °C to 85 °C
- Cycling	-50 °C to 150 °C, 10 cycles
Humidity	
- Operating	40 °C/95% RH, 5 days
- Storage	65 °C/90% RH, 24 hours
- Condensation	40 °C/95% RH
Shock	
- Non-operating:	
- Half-sine	500 G at 0.5 ms, 3 drops/direction
- Transportation	50 G Vibration: 8 m/s ±10%
- Operating	50 G at 6 ms, 6 directions
Vibration	
- Operating	7 G rms, 5 to 2000 Hz at 0.25 in p-p
- Survival	20 G rms, 20 to 2000 Hz at 0.06 in p-p, 4 min/cycle, 4 cycles/axis
- Random	7 G rms, 50 to 2000 Hz, 15 min/axis
ESD immunity	
- Direct discharge	6 kV (to outer conductor)
- Air discharge	15 kV (to outer conductor)
RFI	
	Radiated emission per CISPR 11
Magnetic field	
- Operating emission	AC magnetic emission (1.88 G rms) DC magnetic emission (5 G)
- Operating immunity	30 A/M rms at 47 Hz, 50 Hz, 60 Hz, and 189 Hz 150 A/M rms at 47 Hz and 189 Hz

Physical Specifications

Table 3-8 Physical specifications

Parameter	Specification
Dimensions	Figure 3-4
Net weight, kg (lb)	0.370 (0.82)

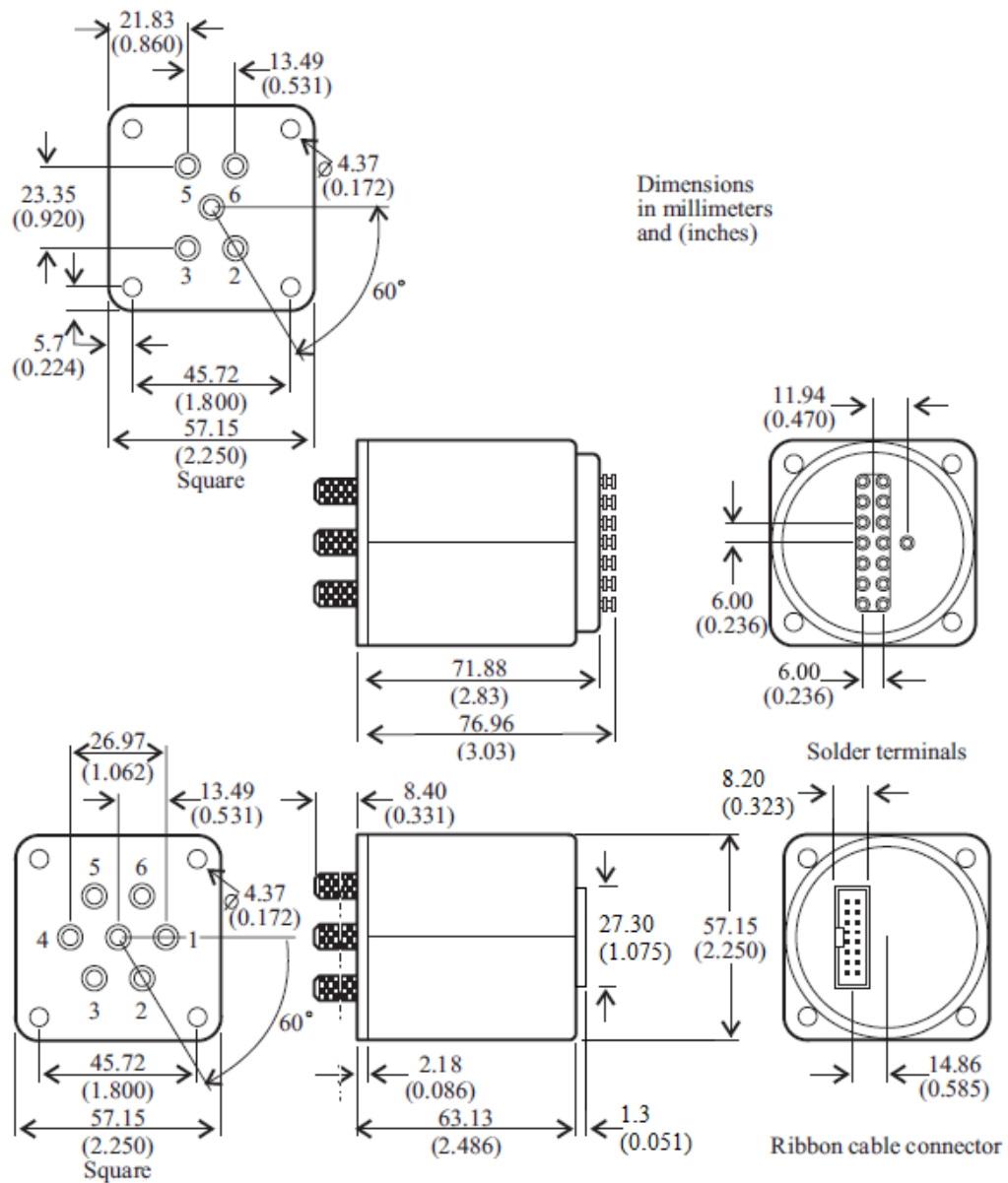

Figure 3-4 Dimensions of Keysight 8710x low PIM coaxial multipoint switches

4 Installation and Verification

Installation	30
Operating and Service Instructions	31

This chapter provides you installation information and simple verification steps of the switches.

Installation

Initial inspection

- 1** Inspect the shipping container for damage. If the shipping container or cushioning material is damaged, it should be kept until the contents of the shipment have been checked for completeness and the instrument has been checked both mechanically and electrically.
 - Check for mechanical damage such as scratches or dents.
 - Procedures for checking electrical performance are given under “**Operator’s check**” on page 31 or “**Performance test**” on page 32.
- 2** If the contents are incomplete, there is mechanical damage or defect, or the instrument does not pass the electrical performance test, contact the nearest Keysight Sales and Service office (refer to “**Sales and Technical Support**” on page 3). Keysight will arrange for repair or replacement of the damaged or defective equipment. Keep the shipping materials for the carrier’s inspection.
- 3** If you are returning the instrument under warranty or for service, repackaging the instrument requires original shipping containers and materials or their equivalents. Keysight can provide packaging materials identical to the original materials. Refer to “**Sales and Technical Support**” on page 3 for the Keysight office nearest to you. Attach a tag indicating the type of service required, return address, model number, and serial number. Mark the container *FRAGILE* to insure careful handling. In any correspondence, refer to the instrument by its model number and serial number.

Operating and Service Instructions

Operator's check

The operator's check is supplied to allow the operator to make a quick check on the coaxial multiport switches prior to use or if a failure is suspected.

CAUTION

ESD exceeding the level specified in **Environmental Specifications** or RF power applied is greater than the maximum specified as in **General Specifications** may cause permanent damage to the device.

Description

The coaxial multiport switch is connected to a network analyzer configured for the S-parameter measurement. The network analyzer may be set to sweep over the whole or selected frequency range of the switch to be verified. The S-parameter measurement is the best way to determine if the switch is working properly.

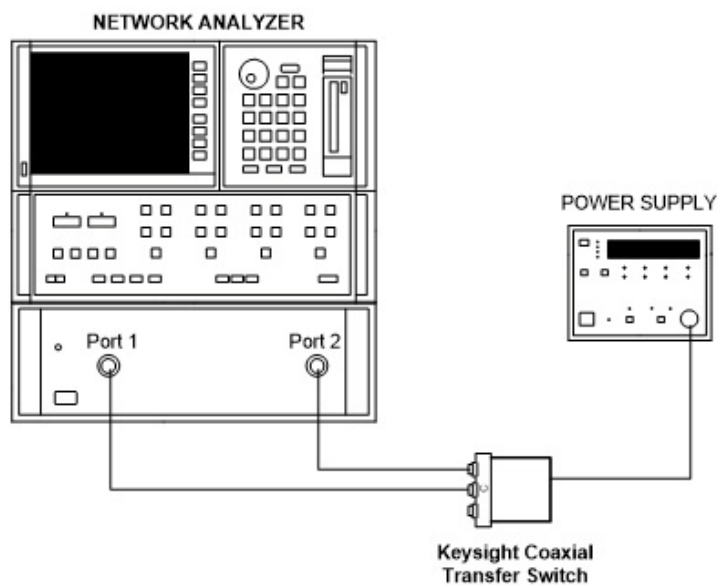

Figure 4-1 Connection to perform quick check

Quick check procedure

- 1 Connect the common port of the switch to Port 1 of the network analyzer and one of the outer RF ports to Port 2 of the network analyzer as illustrated in [Figure 4-1](#).
- 2 For standard drive, apply ground to the corresponding “drive” pin to close the selected path. Refer to [“Standard Drive”](#) on page 17.
- 3 For TTL drive (option T24), apply “High” to the corresponding “drive” pin to close the selected path. Refer to [“TTL Drive \(Option T24\)”](#) on page 18.
- 4 Perform the S-parameter measurement and verify against [“Supplemental specifications \(cold switching\)”](#) on page 22.
- 5 Repeat steps 1 to 4 until all paths are measured and verified.

Performance test

The coaxial multiport switches can be tested to the accuracy of the specifications with a network analyzer or equivalent equipment of suitable accuracy. If a network analyzer is available, test the instrument using the procedure in the analyzer’s operating manual.

Service instructions

Adjustment and repair

N1923/4A low PIM coaxial multiport switches do not require internal adjustments and are not recommended for repair.

NOTE

If any of the low PIM coaxial multiport switches fails within the warranty period, a new unit will be replaced. Refer to [“Replacement units”](#) on page 33 for more details.

Maintenance

The connectors, particularly the connector faces, must be kept clean. For instructions on connecting and care of your connectors, refer to the Microwave Connector Care Quick Reference Card (08510-90360).

Replacement units

Table 4-1 Replacement units

Replacement unit	Part number
Low PIM switch, SP4T, DC - 4 GHz, terminated with Option 100, 024	87104-60066
Low PIM switch, SP4T, DC - 4 GHz, terminated with Option 100, T24	87104-60067
Low PIM switch, SP4T, DC - 4 GHz, terminated with Option 161, 024	87104-60068
Low PIM switch, SP4T, DC - 4 GHz, terminated with Option 161, T24	87104-60069
Low PIM switch, SP4T, DC - 20 GHz, terminated with Option 100, 024	87104-60070
Low PIM switch, SP4T, DC - 20 GHz, terminated with Option 100, T24	87104-60071
Low PIM switch, SP4T, DC - 20 GHz, terminated with Option 161, 024	87104-60072
Low PIM switch, SP4T, DC - 20 GHz, terminated with Option 161, T24	87104-60073
Low PIM switch, SP4T, DC - 26.5 GHz, terminated with Option 100, 024	87104-60074
Low PIM switch, SP4T, DC - 26.5 GHz, terminated with Option 100, T24	87104-60075
Low PIM switch, SP4T, DC - 26.5 GHz, terminated with Option 161, 024	87104-60076
Low PIM switch, SP4T, DC - 26.5 GHz, terminated with Option 161, T24	87104-60077
Low PIM switch, SP6T, DC - 4 GHz, terminated with Option 100, 024	87106-60094
Low PIM switch, SP6T, DC - 4 GHz, terminated with Option 100, T24	87106-60095
Low PIM switch, SP6T, DC - 4 GHz, terminated with Option 161, 024	87106-60096
Low PIM switch, SP6T, DC - 4 GHz, terminated with Option 161, T24	87106-60097
Low PIM switch, SP6T, DC - 20 GHz, terminated with Option 100, 024	87106-60098
Low PIM switch, SP6T, DC - 20 GHz, terminated with Option 100, T24	87106-60099
Low PIM switch, SP6T, DC - 20 GHz, terminated with Option 161, 024	87106-60100
Low PIM switch, SP6T, DC - 20 GHz, terminated with Option 161, T24	87106-60101
Low PIM switch, SP6T, DC - 26.5 GHz, terminated with Option 100, 024	87106-60102
Low PIM switch, SP6T, DC - 26.5 GHz, terminated with Option 100, T24	87106-60103
Low PIM switch, SP6T, DC - 26.5 GHz, terminated with Option 161, 024	87106-60104
Low PIM switch, SP6T, DC - 26.5 GHz, terminated with Option 161, T24	87106-60105

NOTE

The above list of replacement units is not applicable as customer-orderable units. The list only applies for any low PIM coaxial multipoint switch which fails within the warranty period.

THIS PAGE HAS BEEN INTENTIONALLY LEFT BLANK.



This information is subject to change without notice. Always refer to the Keysight website for the latest revision.

© Keysight Technologies 2014 - 2019
Edition 3, March 14, 2019

Printed in Malaysia



87104-80017

www.keysight.com