

SUCOTEST 18

ST18/SMAM/Nm/72 inch cable assembly



Order no. 84004595

Electrical specifications

Impedance	50 Ohm
Operating frequency	18 GHz
Velocity of propagation	77 %
Capacitance	87 pF/m (26.5 pF/ft)
Time delay	4.3 ns/m (1.31 ns/ft)
Insulation resistance	> 5 × 10 ³ MΩ
Dielectric withstand voltage	2500 V rms

Electrical table		up to 2 GHz	2.01 to 4 GHz	4.01 to 6 GHz	6.01 to 12 GHz	12.01 to 18 GHz
Min. return loss	dB	30	28	25	21	19
Max. insertion loss at 25 °C	dB	0.89	1.28	1.58	2.29	2.85
Max. cw power at 25 °C, sea level	W	391	277	225	160	131
Max. insertion loss vs. shaking	dB	0.03	0.03	0.03	0.03	0.03
Max. insertion loss vs. bending	dB	0.03	0.04	0.04	0.05	0.05
Max. insertion loss vs. torsion	dB	0.03	0.04	0.04	0.05	0.05

General specifications

Assembly length	1829 mm (72 inch)
Cable diameter	4.6 mm (0.181 inch)
Temperature range	-55 to + 105 °C
Preferred bending radius	100 mm (4.0 inch)
Connector retention force	> 200 N
Recommended rating torque (SMA)	0.8 to 1.1 Nm (7.1 to 9.7 inch lbs)
Recommended rating torque (N)	0.68 to 1.13 Nm (6.0 to 10.0 inch lbs)
Connector interface (SMA)	MIL-STD-348A/310
Connector interface (N)	MIL-STD-348A/304
Weight	134 g

Materials and finishes

Cable jacket	FEP, blue
Cable dielectric	LDPTFE
Taper sleeves	Santoprene/black
Marking sleeve	crosslinked polyolefin/white
Connector contacts	beryllium-copper, gold plated
Connector insulation	PTFE
Connector body	stainless steel, passivated
Connector nur	stainless steel, passivated
Gasket	silicon rubber

Dimensions

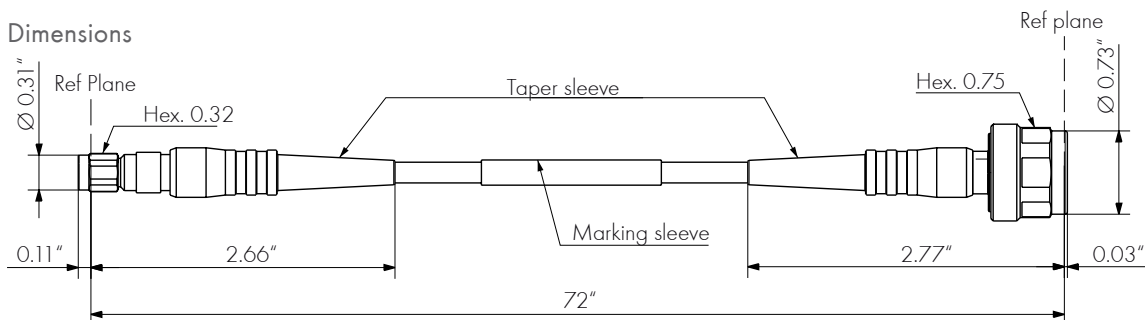

Care and handling instructions for HUBER+SUHNER microwave cable assemblies

HUBER+SUHNER microwave cable assemblies of all types offer a long service life providing they are treated with the appropriate care and attention. Microwave cable assemblies are high precision system components and require proper handling in order to ensure that measuring performance values are maintained.

To achieve the maximum measuring performance the following guidelines should be followed:

1. Assemblies should remain in their original packaging for delivery and storage. Storage temperature should be between +13 °C and +80 °C and the relative humidity should not exceed 85 %.
2. Carefully unpack assemblies before measurement. Avoid kinking cables when straightening from a coil or reel.
3. Ensure that the surroundings are clean and free of dust, dirt and any other particles that could enter unsealed connector interfaces.
4. Use protective caps to prevent contamination whenever connectors are unmated.
5. Where interfaces are contaminated, particles can be removed with dry, oil-free compressed air. Please use eye-protection. Interfaces can be cleaned with dry cotton swabs. Do not use hard hand-tools or solvents. Do not blow into interfaces or use normal compressed-air.
6. Choose the measurement routing using the largest bend radii possible. Small bend radii may affect electrical performance. Exceeding the specified limits during the measurement process could cause a permanent degradation.
7. Avoid twisting microwave cable assemblies. Torsion of this type of assembly can alter the relative diameters of cable layers and affects the electrical characteristics. Exceeding the limit of 10° per metre during measuring process could cause a permanent degradation.
8. Examine interfaces for damage and/or contamination before mating.
9. Discharge connectors before mating or ensure that they are connected to a suitable ground.
10. When mating connectors with a screwed interface always hold the connector bodies and turn only the coupling nut. This avoids twisting the cable and ensures minimum wear on the connector pins.
11. Do not exceed the torque specified.

HUBER+SUHNER AG
RF Division
Degersheimerstrasse 14
9100 Herisau/Switzerland
Tel. +41 71 353 4111
Fax +41 71 353 4590
hubersuhner.com

HUBER+SUHNER is certified according to EN(AS) 9100, ISO 9001, ISO 14001, ISO/TS 16949 and IRIS.

Waiver

Fact and figures herein are for information only and do not represent any warranty of any kind.