

Manta

G-895



- Latest Sony CMOS sensor
- Power over Ethernet option
- Angled head and board level variants
- Video-iris lens control

Description

GigE Vision camera featuring the Sony IMX267 CMOS sensor, Pregius global shutter

Manta G-895B/G-895C is a machine vision camera that incorporates the high quality Type 1 (16.1 mm diagonal) Sony IMX267 CMOS sensor with Pregius global shutter technology. At full resolution, this camera runs 13.4 frames per second. With a smaller region of interest, higher frame rates are possible. The Manta is one of Allied Vision's versatile GigE Vision cameras with a wide range of features. Particular highlights are the three look-up tables, sophisticated color correction capabilities, a robust metal housing, and many modular options.

By default monochrome models ship with protection glass B 270 (ASG) and color models ship with an IRC Hoya C-5000 IR cut filter.

Options:

- Power over Ethernet (PoE)
- Various optical filter and lens mount options
- Angled head, board level variants, white medical housing

See the [Modular Concept](#) for lens mount, housing variants, optical filters, case design, and other modular options.

Specifications

Manta	G-895
Interface	IEEE 802.3 1000BASE-T, IEEE 802.3af (PoE) optional
Resolution	4112 (H) × 2176 (V)
Sensor	Sony IMX267

Manta	G-895
Sensor type	CMOS
Cell size	3.45 μm x 3.45 μm
Lens mount	C-Mount
Max frame rate at full resolution	13.4 fps
ADC	12 bit
Image buffer (RAM)	128 MByte
Output	
Bit depth	8-12 bit
Mono modes	Mono8, Mono12Packed, Mono12
Color modes YUV	YUV411Packed, YUV422Packed, YUV444Packed
Color modes RGB	RGB8Packed, BGR8Packed
Raw modes	BayerRG8, BayerRG12, BayerRG12Packed
General purpose inputs/outputs (GPIOs)	
Opto-isolated I/Os	2 inputs, 2 outputs
RS-232	1
Operating conditions/dimensions	
Operating temperature	+5 °C to +45 °C ambient (without condensation)
Power requirements (DC)	8 to 30 VDC; PoE
Power consumption (@12 V)	2.7 W @ 12 VDC; 3.1 W PoE
Mass	190 g; 200 g (PoE)
Body dimensions (L × W × H in mm)	86.4 × 44 × 29 (including connectors)
Regulations	CE, RoHS, REACH, WEEE, FCC, ICES

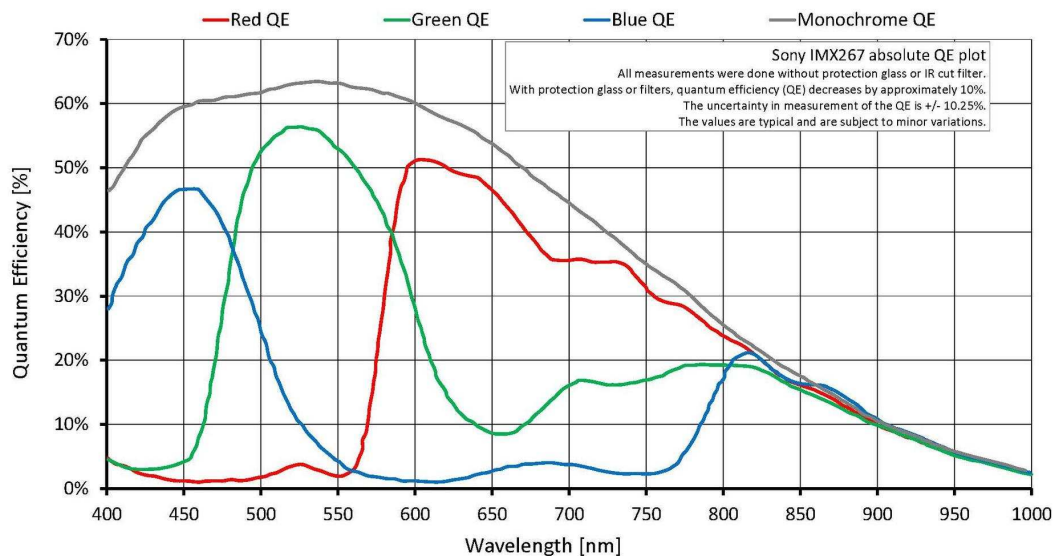

Features

Image optimization features:

- Auto gain (manual gain control: 0 to 40 dB; 0.1 dB increments)
- Auto exposure (exposure time control varies by pixel format)
- Auto white balance (color models only)
- Binning
- Black level (offset)
- Color correction, hue, saturation (color models only)
- Decimation X/Y
- Gamma correction
- Look-up tables (LUTs) (3)
- Region of interest (ROI), separate ROI for auto features
- Reverse X/Y

Camera control features:

- Auto-iris (video type)
- Event channel
- Image chunk data
- IEEE 1588 Precision Time Protocol
- Storable user sets
- StreamBytesPerSecond (easy bandwidth control)
- Stream hold
- Sync out modes: Trigger ready, input, exposing, readout, imaging, strobe, GPO
- Temperature monitoring (main board)
- Trigger over Ethernet (ToE) Action Commands

Technical drawing

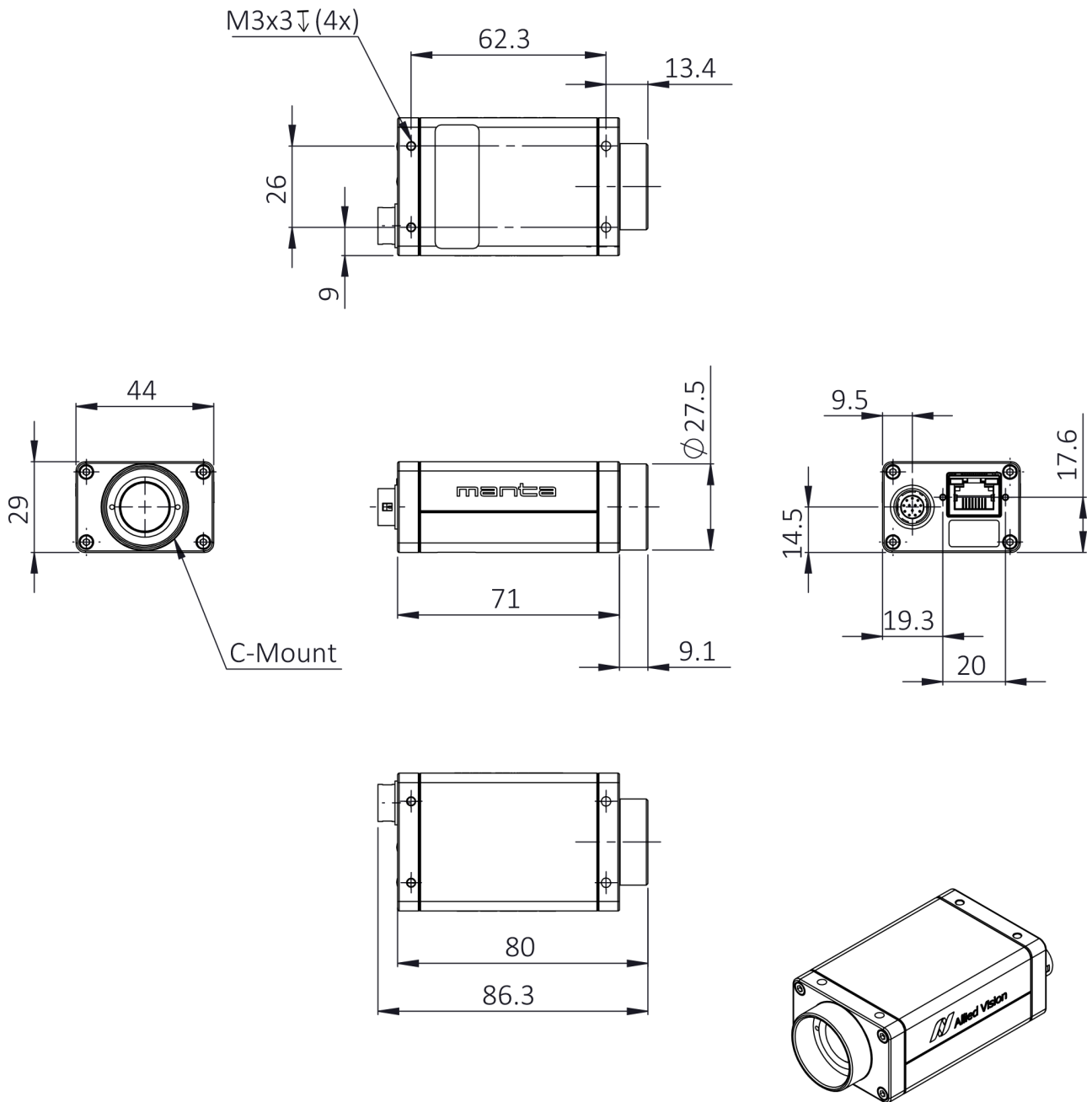



Applications

Manta G-895B/G-895C is ideal for a wide range of applications including:

- Machine Vision
- Broadcast analysis requiring full HD such as sports analytics
- Industrial inspection
- Security and surveillance
- Intelligent traffic solutions (ITS), traffic (traffic monitoring, speed enforcement, toll collection)
- Low light / high sensitivity conditions
- Outdoor applications with dynamic lighting situations