

# Prosilica GC

## 1350



- Compact
- 20 fps @ 1.4 Megapixel
- Rugged housing
- Video-type auto iris

## Description

1.4 Megapixel CCD camera with GigE Vision

Prosilica GC1350 is a high-resolution CCD camera with Gigabit Ethernet interface (GigE Vision). GC1350 incorporates a high-quality Sony CCD sensor providing excellent monochrome and color image quality. GC1350 runs 20 frames per second at 1360 x 1024 resolution and even faster with region of interest readout.

Options

- IR cut filter, CS-Mount

## Specifications

<b>Prosilica GC</b>	<b>1350</b>
Interface	IEEE 802.3 1000baseT
Resolution	1360 × 1024
Sensor	Sony ICX205
Sensor type	CCD Progressive
Sensor size	Type 1/2
Cell size	4.65 μm
Lens mount	C (adjustable)
Max frame rate at full resolution	20 fps
ADC	12 bit
On-board FIFO	16 Mbyte
<b>Output</b>	
Bit depth	8/12 bit
Mono modes	Mono8, Mono12, Mono12Packed

<b>Prosilica GC</b>	<b>1350</b>
Color modes RGB	RGB8Packed, BGR8Packed
Raw modes	BayerRG8, BayerRG12, BayerGR12Packed
<b>General purpose inputs/outputs (GPIOs)</b>	
TTL I/Os	1 input, 1 output
Opto-isolated I/Os	1 input, 1 output
RS-232	1
<b>Operating conditions/dimensions</b>	
Operating temperature	0°C ... +50°C
Power requirements (DC)	5-25 VDC*
Power consumption (@12 V)	3 W
Mass	100 g
Body dimensions (L × W × H in mm)	59 × 46 × 33 including connectors, w/o tripod and lens
Regulations	CE, FCC Class A, RoHS (2011/65/EU)

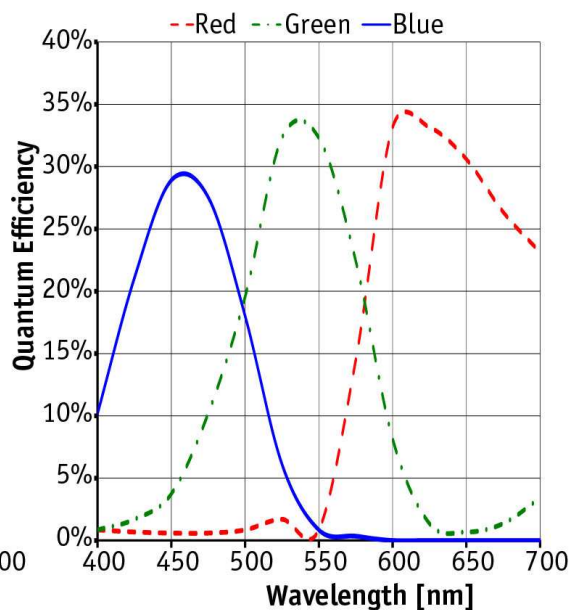
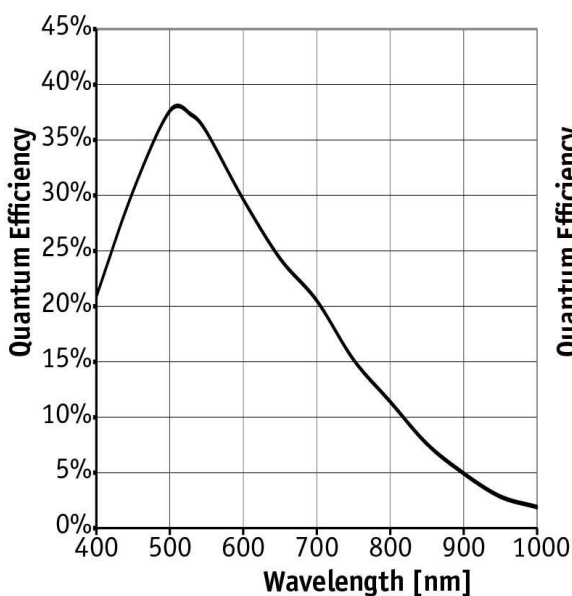

## Features

Prosilica GC1350 features include:

- Video-type auto iris
- ROI, DSP subregion (selectable ROI for auto features)
- Binning
- Auto gain (manual gain control: 0 to 25 dB)



- Auto exposure (manual exposure controls: 12  $\mu$ s to 116.8 s)
- Auto white balance
- StreamBytesPerSecond (easy bandwidth control)
- Stream hold
- Sync out modes: Trigger ready, input, exposing, readout, imaging, strobe, GPO
- Global shutter (digital shutter)
- Recorder and Multiframe acquisition modes
- Event channel
- Chunk data
- Storable user sets

## Technical drawing

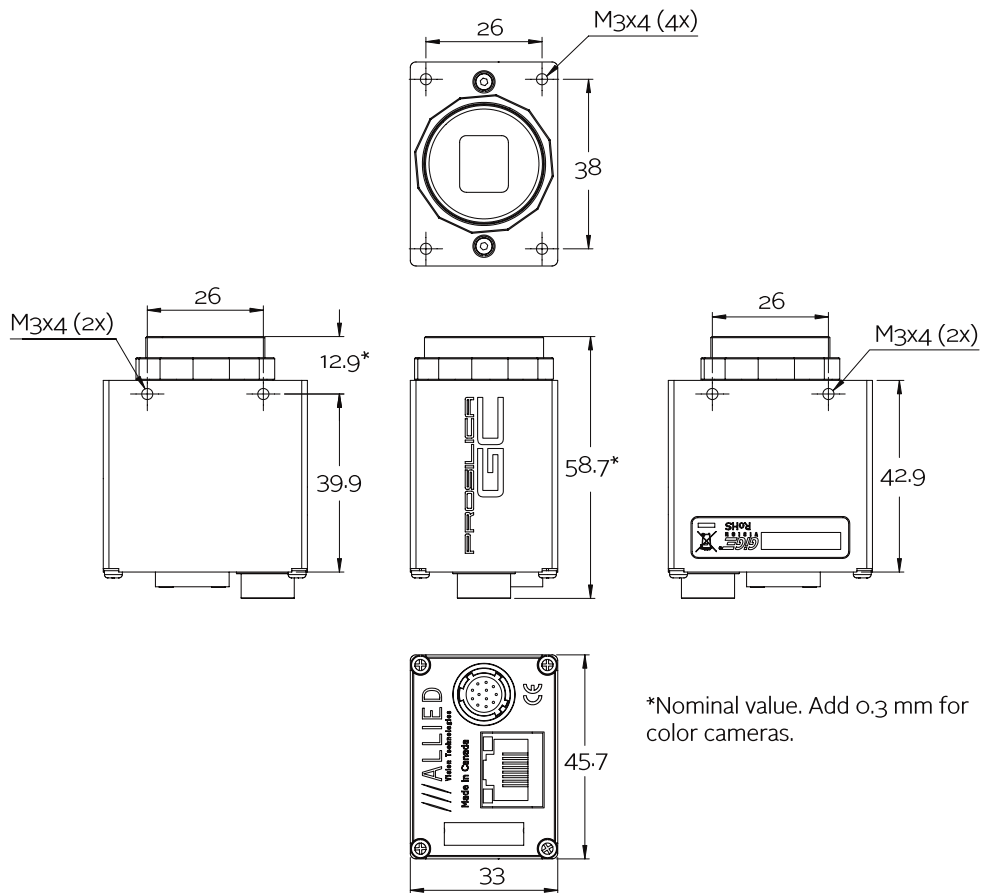



## Applications

Prosilica GC1350 is ideal for a wide range of applications including:

- Industrial inspection
- Machine vision
- Ophthalmology
- Aeronautical and aerospace
- Public security
- Surveillance
- Traffic imaging
- OEM applications