

Prosilica GC

650



- Compact
- High frame rate
- Rugged housing
- Video-type auto iris

Description

Very small VGA CCD camera with GigE Vision

Prosilica GC650 is a fast, VGA-resolution, high-performance machine vision camera with Gigabit Ethernet interface (GigE Vision). The CCD sensor has excellent image quality and sensitivity. The camera is suitable for applications where speed and excellent image quality are key requirements.

Options

- IR cut filter, CS-Mount

Specifications

Prosilica GC	650
Interface	IEEE 802.3 1000baseT
Resolution	659 × 493
Sensor	Sony ICX424
Sensor type	CCD Progressive
Sensor size	Type 1/3
Cell size	7.4 μm
Lens mount	C (adjustable) / CS
Max frame rate at full resolution	90 fps
ADC	12 bit
On-board FIFO	16 Mbyte
Output	
Bit depth	8/12 bit
Mono modes	Mono8, Mono12, Mono12Packed
Color modes RGB	RGB8Packed, BGR8Packed

Prosilica GC	650
Raw modes	BayerRG8, BayerRG12, BayerGR12Packed
General purpose inputs/outputs (GPIOs)	
TTL I/Os	1 input, 1 output
Opto-isolated I/Os	1 input, 1 output
RS-232	1
Operating conditions/dimensions	
Operating temperature	0°C ... +50°C
Power requirements (DC)	5–25 VDC*
Power consumption (@12 V)	3 W
Mass	99 g
Body dimensions (L × W × H in mm)	59 × 46 × 33 including connectors, w/o tripod and lens
Regulations	CE, FCC Class A, RoHS (2011/65/EU)

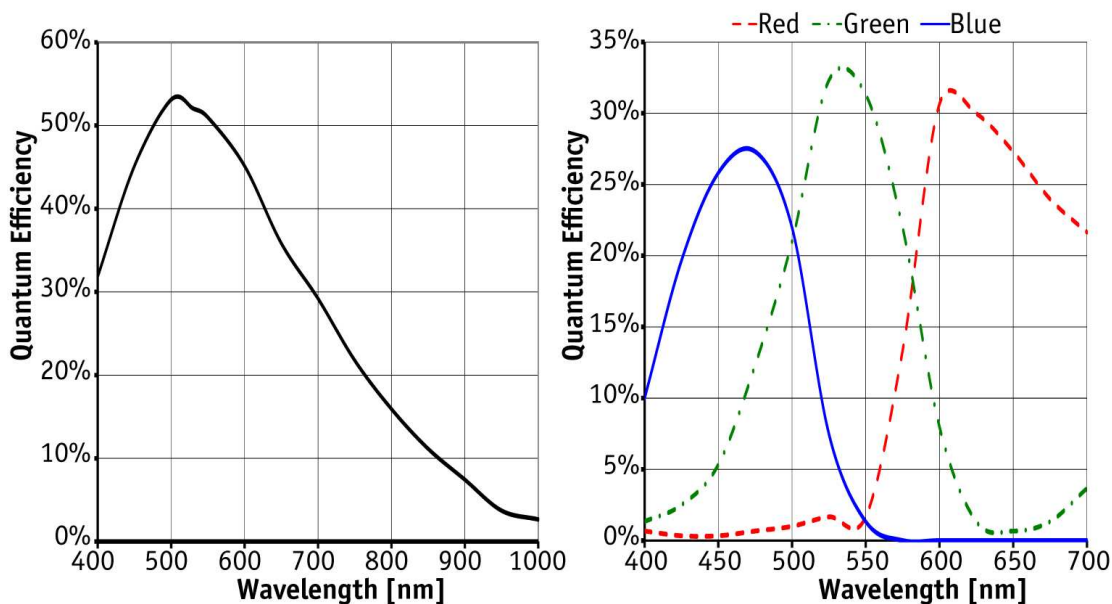

Features

Prosilica GC650 features include:

- Video-type auto iris
- ROI, DSP subregion (selectable ROI for auto features)
- Binning
- Auto gain (manual gain control: 0 to 19 dB)
- Auto exposure (manual exposure controls: 10 μ s to 116.8 s)



- Auto white balance
- StreamBytesPerSecond (easy bandwidth control)
- Stream hold
- Sync out modes: Trigger ready, input, exposing, readout, imaging, strobe, GPO
- Global shutter (digital shutter)
- Recorder and Multiframe acquisition modes
- Event channel
- Chunk data
- Storable user sets

Technical drawing

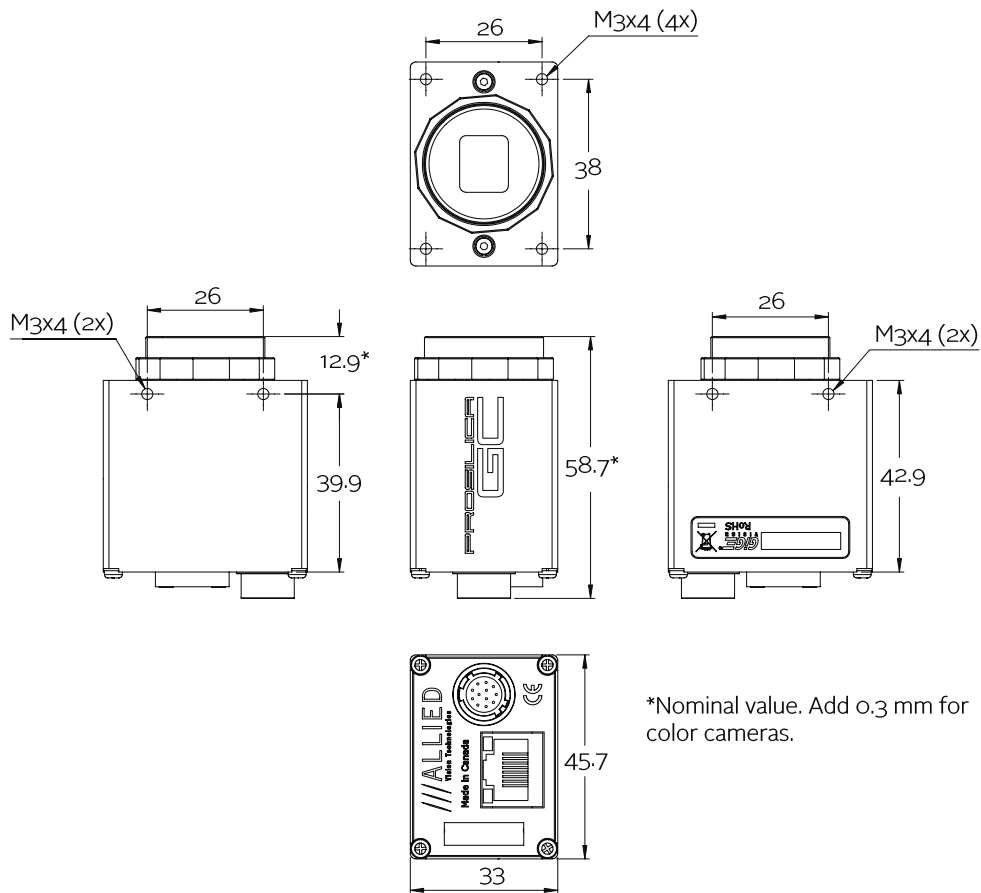



Applications

Prosilica GC650 is suitable for applications where speed and excellent image quality are key requirements. These include:

- Machine vision
- Industrial inspection
- Public security
- Traffic monitoring
- Robotics