

Manta

G-282



- Versatile 2.8 Megapixel camera
- 35 fps @ 1920 × 1080
- PoE optional
- Video-iris lens control

Description

GigE camera with Sony ICX687

Manta G-282B/C includes an 1/1.8" Sony ICX687 sensor with EXview HAD II technology. This sensor has the same resolution as the ICX674 at a more cost-effective price level. At HD resolution (1920 x 1080), it runs 35 fps.

Options

- PoE (Power over Ethernet)
- Various IR cut/pass filters and lens mounts
- White medical housing

Specifications

Manta	G-282
Interface	IEEE 802.3 1000BASE-T, IEEE 802.3af (PoE) optional
Resolution	1936 × 1458
Sensor	Sony ICX687
Sensor type	CCD Progressive
Sensor size	Type 1/1.8
Cell size	3.69 μm
Lens mount	C-Mount
Max frame rate at full resolution	30 fps
ADC	12 bit
On-board FIFO	128 Mbyte
	Output
Bit depth	8-12 bit

Manta	G-282
Mono modes	Mono8, Mono12Packed, Mono12
Color modes YUV	YUV411Packed, YUV422Packed, YUV444Packed
Color modes RGB	RGB8Packed, BGR8Packed
Raw modes	BayerRG8, BayerRG12Packed, BayerRG12
General purpose inputs/outputs (GPIOs)	
Opto-isolated I/Os	2 inputs, 2 outputs
RS-232	1
Operating conditions/dimensions	
Operating temperature	+5 °C ... +45 °C
Power requirements (DC)	PoE, or 8-30 VDC
Power consumption (@12 V)	4.1 W (PoE) / 3.5 W (non-PoE)
Mass	200 g (PoE) / 190 g (non-PoE)
Body dimensions (L × W × H in mm)	86.4 × 44 × 29 mm incl. connectors
Regulations	CE, FCC Class B, RoHS

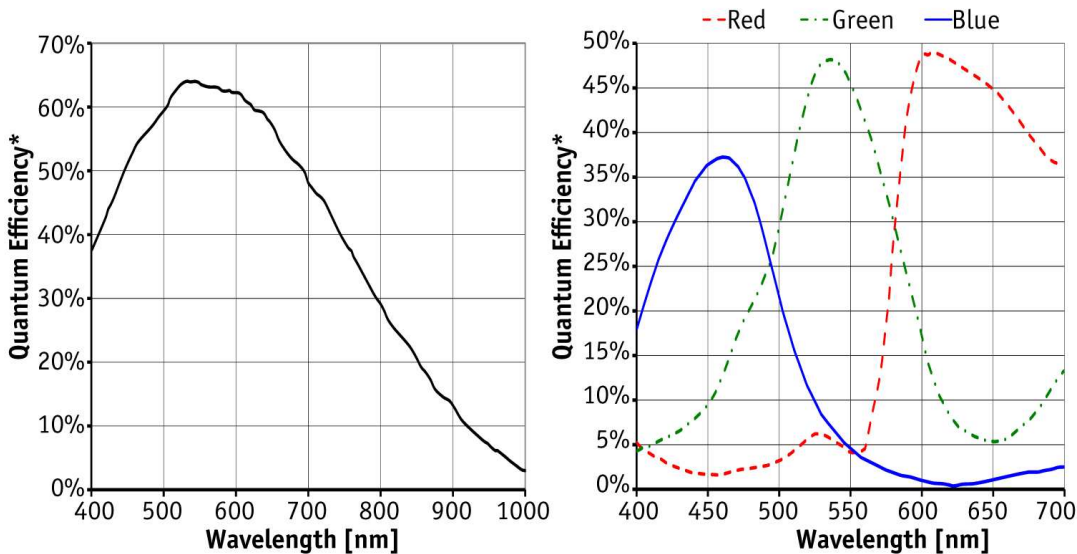

*QE measured without protection glass or filters. With glass or filters, quantum efficiency decreases by approximately 10%.

Features

- Precision Time Protocol (IEEE 1588)
- Camera temperature monitoring
- Video-type auto iris
- ROI, separate ROI for auto features
- Binning
- Decimation



- Auto gain (manual gain control: 0 to 32 dB)
- Auto exposure (41 μ s to 38 s)
- Auto white balance
- LUTs (look-up tables)
- Gamma
- Hue, saturation, color correction
- StreamBytesPerSecond (easy bandwidth control)
- Stream hold
- Sync out modes: Trigger ready, input, exposing, readout, imaging, strobe, GPO
- Event channel
- Chunk data
- Storable user sets

Technical drawing

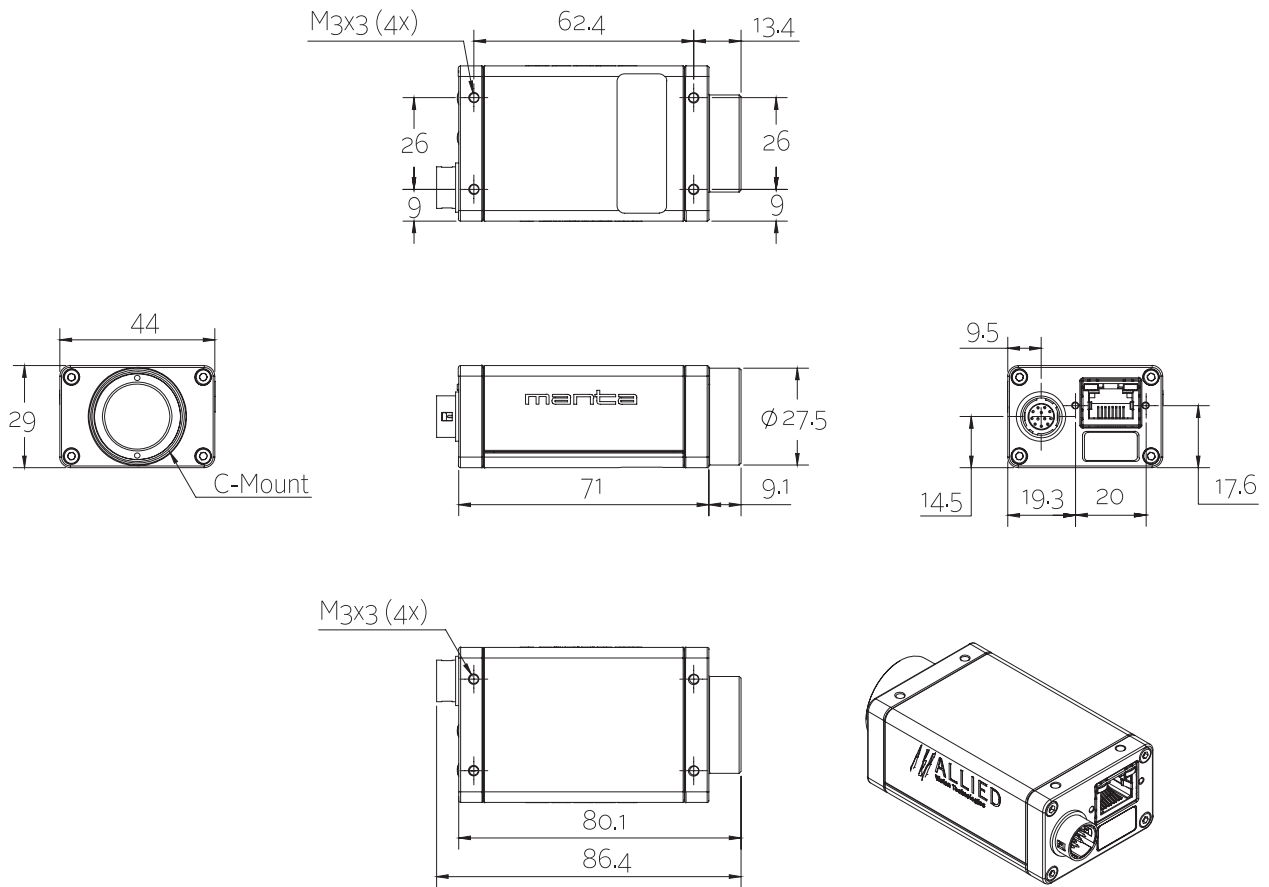



Applications

Manta G-282 is a robust industrial camera with 35 fps at HD resolution (1920 x 1080). It offers several modular options (for example, PoE).

- Multimedia and entertainment
- Machine vision
- Security and surveillance
- Metrology and inspection systems
- Industrial image processing