



Guppy PRO

F-201



- Compact 2 MP camera
- Robust metal housing
- ICX274
- Optocoupled I/Os

Description

2 Megapixel camera, ICX274, attractive price

The Guppy PRO F-201B/C is a 2 Megapixel 1394b camera with a robust metal housing and Sony's ICX274 sensor. At full resolution, it runs 14 fps.

Options

- Various IR cut/pass filters
- White medical housing

Specifications

Guppy PRO	F-201
Interface	IEEE 1394b - 800 Mb/s, 1 port
Resolution	1624 × 1234
Sensor	Sony ICX274
Sensor type	CCD Progressive
Sensor size	Type 1/1.8
Cell size	4.4 μm
Lens mount	C-Mount
Max frame rate at full resolution	14 fps
ADC	12 bit
On-board FIFO	0 Mbyte
	Output
Bit depth	8-12 bit
Mono modes	8/12/16
Color modes RGB	RGB8

Guppy PRO	F-201
Raw modes	8/12/16
General purpose inputs/outputs (GPIOs)	
Opto-isolated I/Os	1/3
Operating conditions/dimensions	
Operating temperature	+5 °C ... +45 °C
Power requirements (DC)	8 V - 36 V
Power consumption (@12 V)	<3.5 W
Mass	80 g
Body dimensions (L × W × H in mm)	44.8 × 29 × 29 mm incl. connectors
Regulations	CE, FCC Class B, RoHS

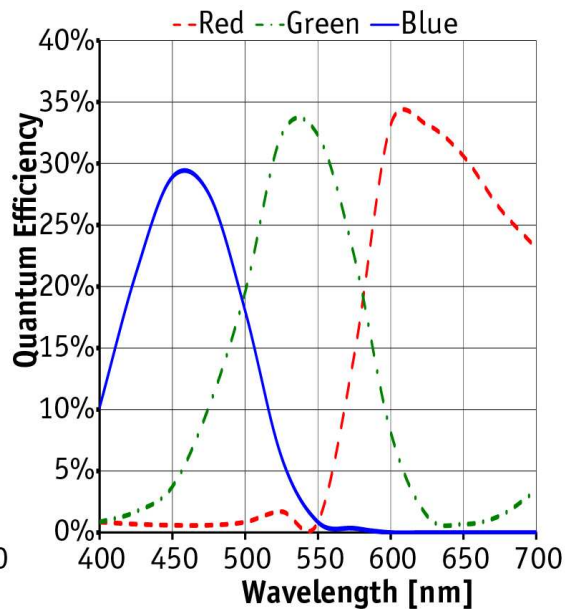
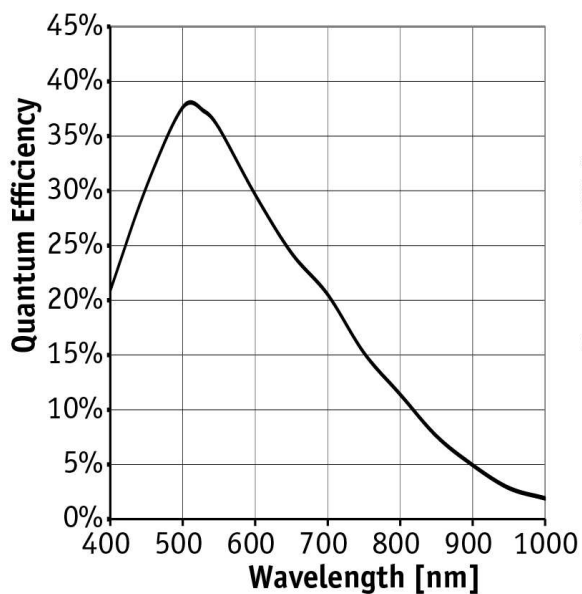

Features

- LUT (look-up table)
- Gamma
- Color correction
- AOI, separate AOI for auto features
- Binning
- Sub-sampling
- Auto gain (manual gain control: 0 to 24.4 dB)
- Auto exposure (55 μ s to 67 s)
- Trigger programmable, level, single, bulk, programmable delay
- Storable user sets

Technical drawing

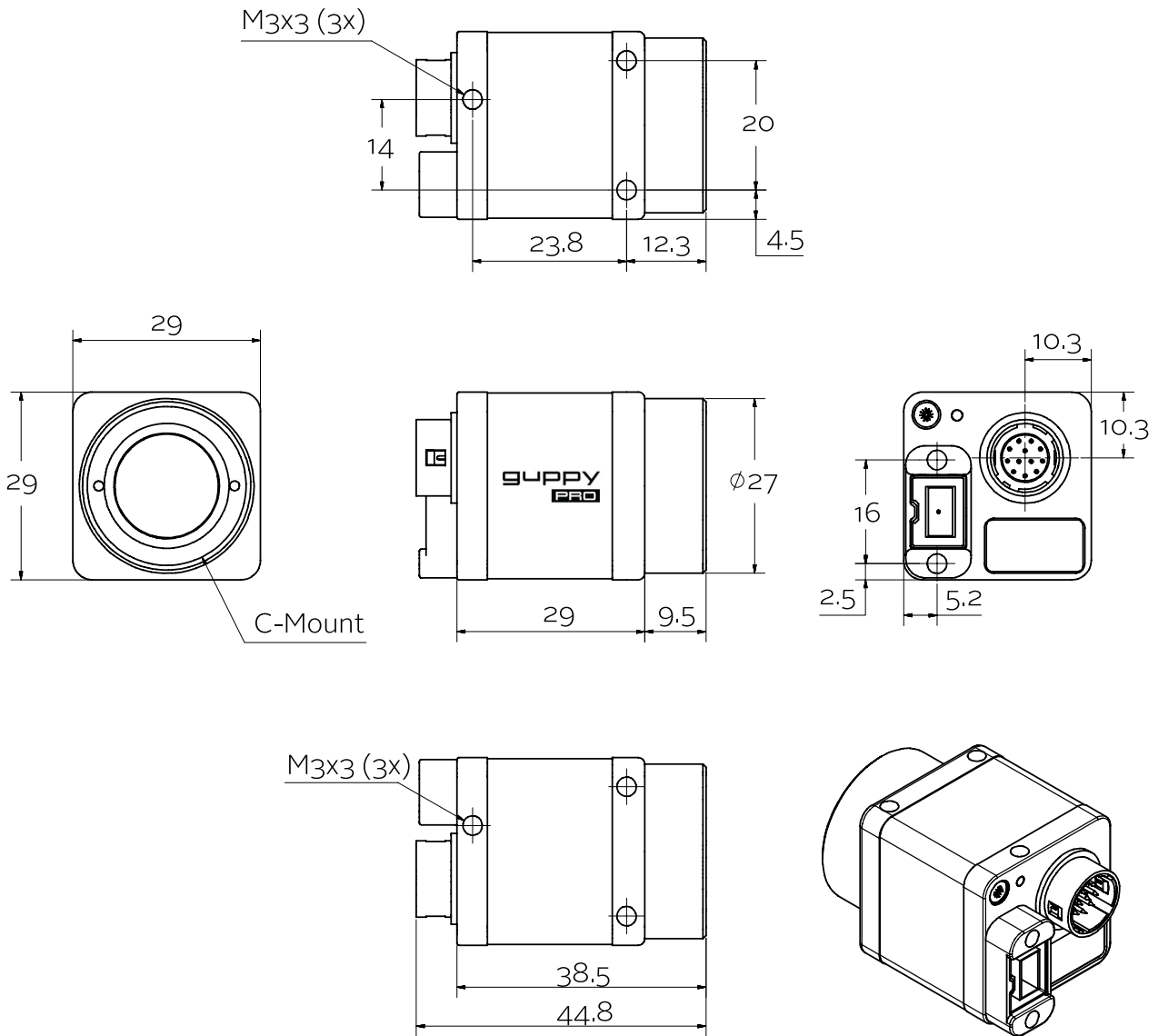



Applications

The Guppy PRO F-201 suits particularly well for applications with space constraints. Besides this, it has an excellent price/performance ratio.

Typical applications:

- Machine vision
- Robotics
- Logistics
- Pharmaceutical industry
- Multimedia
- ITS/Traffic monitoring
- ... and more