

Mako G

G-125



- Ultra-compact (60.5 × 29 × 29 mm)
- Affordable
- PoE
- 30 fps @ 1.2 Megapixel

Description

GigE camera with Sony ICX445 sensor

Mako G-125B/C is an industrial GigE camera with Sony's ICX445 sensor. Mako G cameras have the same 29 x 29 mm form factor and the same mounting positions as many analog cameras. All models include PoE, three opto-isolated outputs, and a 64 MB FIFO image buffer. The image quality profits from the precisely aligned sensors.

Options

- Various IR cut/pass filters, protection glass, various lens mounts
- White medical housing

Specifications

Mako G	G-125
Interface	IEEE 802.3 1000BASE-T, IEEE 802.3af (PoE)
Resolution	1292 × 964
Sensor	Sony ICX445
Sensor type	CCD Progressive
Sensor size	Type 1/3
Cell size	3.75 μm
Lens mount	C/CS-Mount
Max frame rate at full resolution	30 fps
ADC	14 bit
On-board FIFO	64 Mbyte
	Output
Bit depth	8/12 bit

Mako G	G-125
Mono modes	Mono8, Mono12, Mono12Packed
Color modes YUV	YUV411Packed, YUV422Packed, YUV444Packed
Color modes RGB	RGB8Packed, BGR8Packed
Raw modes	BayerRG8, BayerRG12, BayerRG12Packed
General purpose inputs/outputs (GPIOs)	
Opto-isolated I/Os	1 input, 3 outputs
Operating conditions/dimensions	
Operating temperature	+5°C to +45°C (housing temperature)
Power requirements (DC)	PoE /12 V - 24 V
Power consumption (@12 V)	2.7 W (PoE) / 2.3 W (non-PoE)
Mass	80 g
Body dimensions (L × W × H in mm)	60.5 × 29 × 29 mm, incl. connectors
Regulations	CE, FCC Class B, RoHS

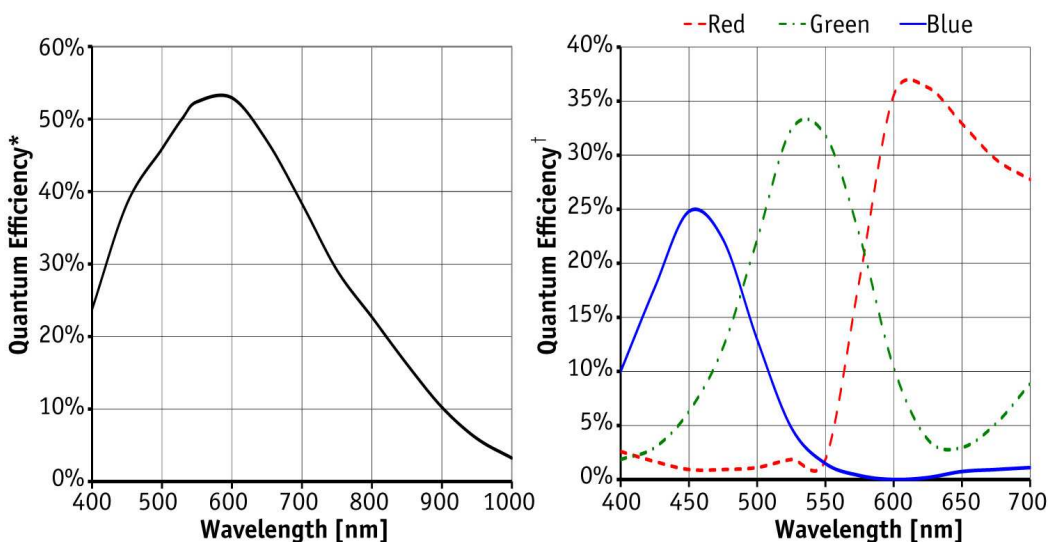

*QE measured without protection glass or filters. With glass or filters, quantum efficiency decreases by approximately 10%.

†QE measured with IR cut filter. Without IR cut filter, quantum efficiency increases by approximately 10%.

Features

- Camera temperature monitoring
- ROI, separate ROI for auto features
- Binning
- Auto gain (manual gain control: 0 to 30 dB)
- Auto exposure (manual exposure control: 12 μ s to 84 s)
- Auto white balance
- LUTs (look-up tables)



- Gamma
- Hue, saturation, color correction
- StreamBytesPerSecond (easy bandwidth control)
- Stream hold
- Sync out modes: Trigger ready, input, exposing, readout, imaging, strobe, GPO
- Event channel
- Chunk data
- Storable user sets

Technical drawing

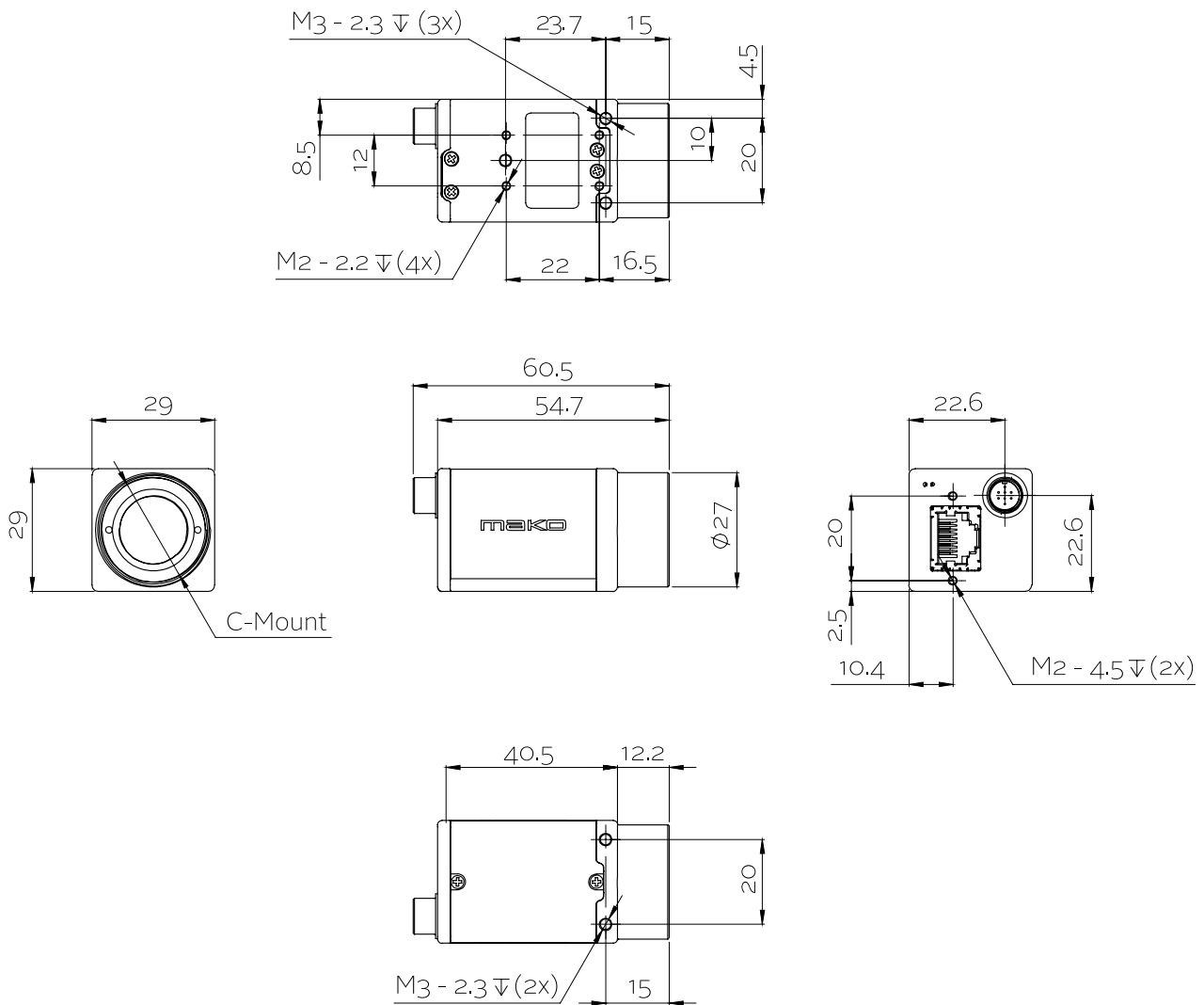



Applications

Mako G is an inexpensive industrial GigE camera with a compact form factor. It is suitable for all typical machine vision applications:

- Robotics
- Quality control
- Inspection, surveillance
- Industrial imaging
- Machine vision
- Logistics