

Manta

G-032



- Versatile VGA camera
- PoE optional
- Angled head and boardlevel variants
- Video-iris lens control

Description

Value packed Machine Vision camera, VGA, Sony ICX424, PoE option

Manta G-032B/C is a value packed GigE Vision camera with VGA resolution and a Sony ICX424 sensor. It runs at 80 fps (full resolution). With a smaller ROI, higher frame rates are possible.

It incorporates three LUTs, sophisticated color correction algorithms, a robust metal housing, and many modular options.

Options

- PoE (Power over Ethernet)
- Various IR cut/pass filters and lens mounts
- Angled head, board level version, white medical housing

Specifications

Manta	G-032
Interface	IEEE 802.3 1000BASE-T, IEEE 802.3af (PoE) optional
Resolution	656 × 492
Sensor	Sony ICX424
Sensor type	CCD Progressive
Sensor size	Type 1/3
Cell size	7.4 μm
Lens mount	C/CS-Mount
Max frame rate at full resolution	80 fps
ADC	12 bit
On-board FIFO	32 Mbyte
	Output
Bit depth	8-12 bit

Manta	G-032
Mono modes	Mono8, Mono12, Mono12Packed
Color modes YUV	YUV411Packed, YUV422Packed, YUV444Packed
Color modes RGB	RGB8Packed, BGR8Packed, RGBA8Packed, BGRA8Packed
Raw modes	BayerRG8, BayerRG12Packed, BayerRG12
General purpose inputs/outputs (GPIOs)	
Opto-isolated I/Os	2 inputs, 2 outputs
RS-232	1
Operating conditions/dimensions	
Operating temperature	+5 °C ... +45 °C
Power requirements (DC)	PoE, or 8-30 VDC
Power consumption (@12 V)	4.2 W (PoE) / 3.6 W (non-PoE)
Mass	210 g (PoE) / 200 g (non-PoE)
Body dimensions (L × W × H in mm)	86.4 × 44 × 29 mm incl. connectors
Regulations	CE, FCC Class B, RoHS

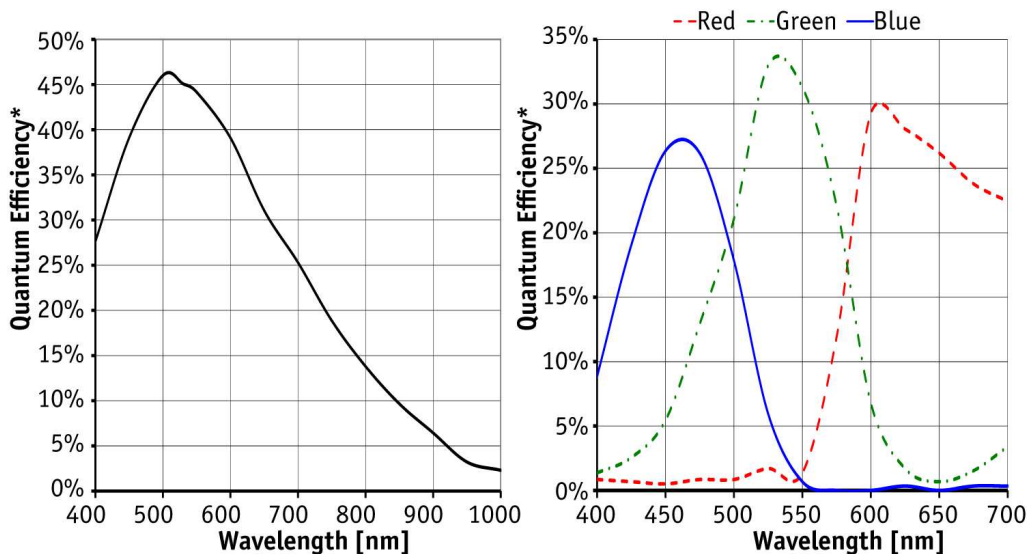

*QE measured without protection glass or filters. With glass or filters, quantum efficiency decreases by approximately 10%.

Features

- Video-type auto iris
- ROI, separate ROI for auto features
- Binning
- Auto gain (manual gain control: 0 to 36 dB)
- Auto exposure (26 μ s to 60 s)



- Auto white balance
- LUTs (look-up tables)
- Gamma
- Hue, saturation, Color correction
- StreamBytesPerSecond (easy bandwidth control)
- Stream hold
- Sync out modes: Trigger ready, input, exposing, readout, imaging, strobe, GPO
- Event channel
- Chunk data
- Storable user sets

Technical drawing

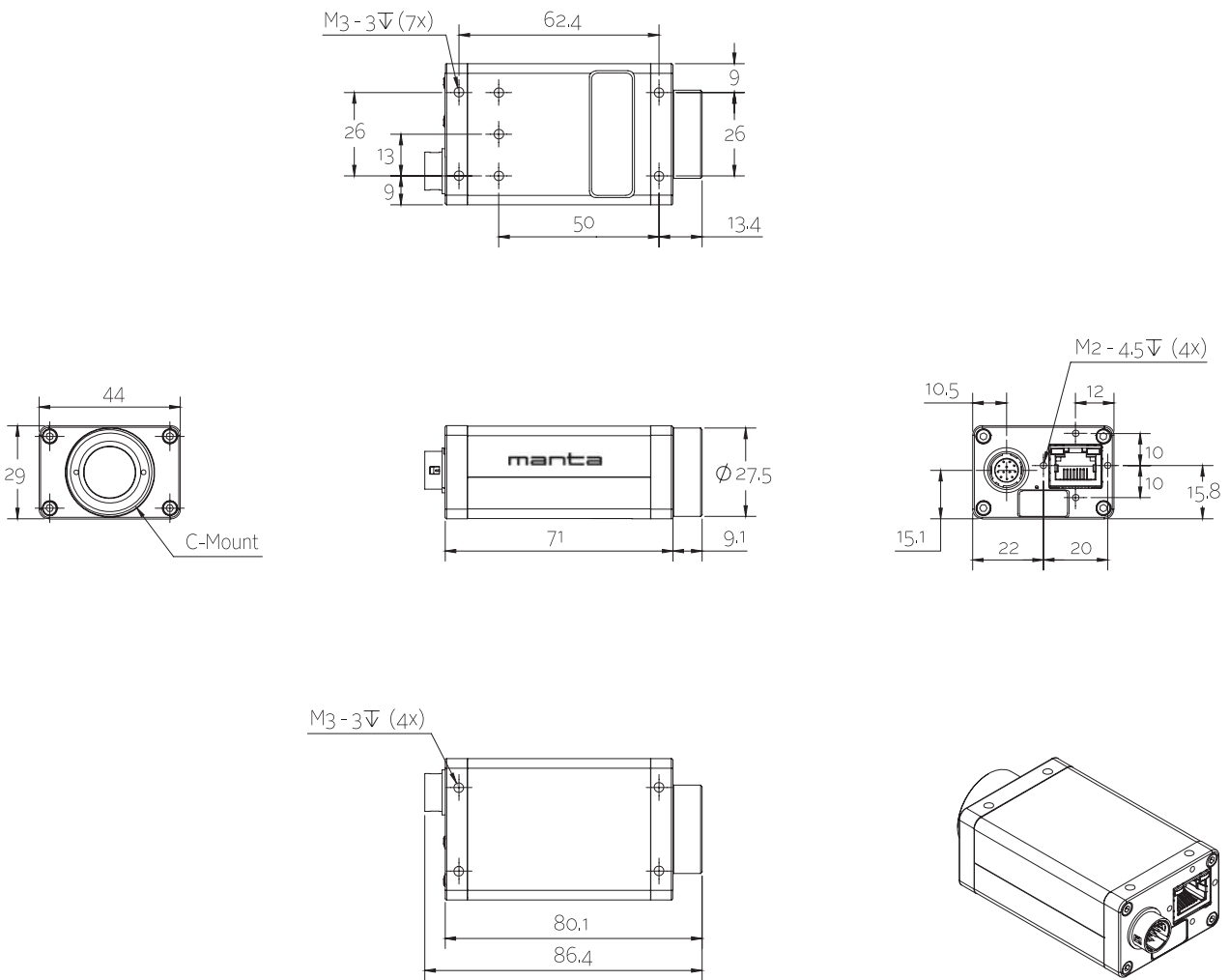

Applications

Manta G-032B/C is a flexible, value packed VGA GigE Vision PoE camera



for a variety of machine vision and inspection applications. On request, board level versions with separate sensor head (up to 200 mm distance to camera mainboard) are available. The Manta incorporates three LUTs (separate R, G, and B control), color correction, and many more features.

- Semiconductor inspection
- Food inspection
- Printing marks control
- Pharmaceutical inspection
- Ophthalmology
- Machine vision
- ITS/Traffic monitoring
- ... and many more