

Prosilica GT

1600



- Versatile temperature range for extreme environments
- PTP
- PoE
- P-Iris and DC-Iris lens control

Description

2 Megapixel CCD camera for extreme environments - GigE Vision®

Prosilica GT1600 is a 2 Megapixel camera with a Gigabit Ethernet interface (GigE Vision®). GT1600 incorporates a high-quality Sony ICX274 CCD sensor providing excellent monochrome and color image quality. GT1600 is a rugged camera designed to operate in extreme environments and fluctuating lighting conditions. GT1600 offers Precise iris lens control allowing users to fix the aperture size to optimize depth of field, exposure, and gain without the need for additional control elements.

Options:

- Various IR cut/pass filters and lens mounts

Specifications

Prosilica GT	1600
Interface	IEEE 802.3 1000BASE-T, IEEE 802.3af (PoE)
Resolution	1620 × 1220
Sensor	Sony ICX274
Sensor type	CCD Progressive
Cell size	4.4 μm
Lens mount	C-Mount, CS-Mount
Max frame rate at full resolution	25.8 fps
ADC	14 bit
On-board FIFO	128 Mbyte
Output	
Bit depth	14 (mono) - 12 (color) bit
Mono modes	Mono8, Mono12, Mono12Packed, Mono14
Color modes YUV	YUV411Packed, YUV422Packed, YUV444Packed
Color modes RGB	RGB8Packed, BGR8Packed

Prosilica GT	1600
Raw modes	BayerRG8, BayerRG12, BayerGR12Packed
General purpose inputs/outputs (GPIOs)	
TTL I/Os	1 input, 2 outputs
Opto-isolated I/Os	1 input, 2 outputs
RS-232	1
Operating conditions/dimensions	
Operating temperature	-20°C ... +65°C
Power requirements (DC)	PoE, or 7-25 VDC
Power consumption (@12 V)	4.0 W (PoE) / 3.3 W @ 12 VDC
Mass	211 g
Body dimensions (L × W × H in mm)	86 × 53.3 × 33 (including connectors, w/o tripod and lens)
Regulations	CE, FCC Class A, RoHS (2011/65/EU)

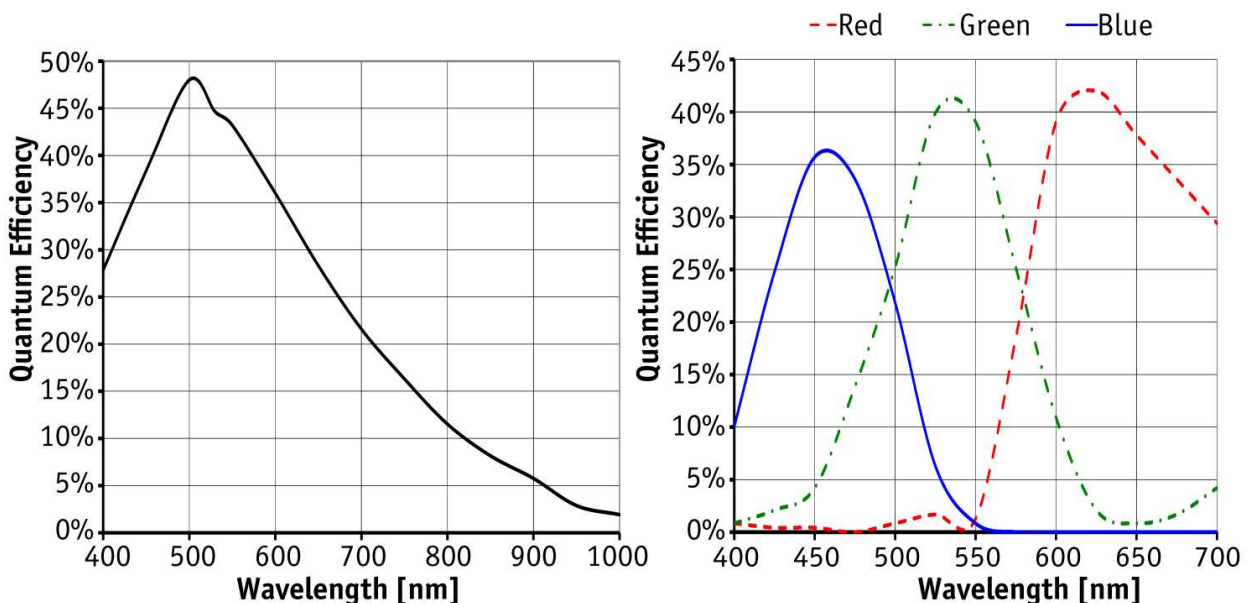

Features

Prosilica GT1600 features include:

- Precision Time Protocol (IEEE 1588)
- Camera and sensor temperature monitoring
- Auto iris (P-Iris and DC-Iris)
- ROI, separate ROI for auto features
- Binning



- Auto gain (manual gain control: 0 to 26 dB)
- Auto exposure (manual exposure control: 10 μ s to 68.7 s)
- Auto white balance
- Gamma
- Hue, saturation, color correction
- StreamBytesPerSecond (easy bandwidth control)
- Stream hold
- Sync out modes: Trigger ready, input, exposing, readout, imaging, strobe, GPO
- Event channel
- Chunk data
- Storable user sets

Technical drawing

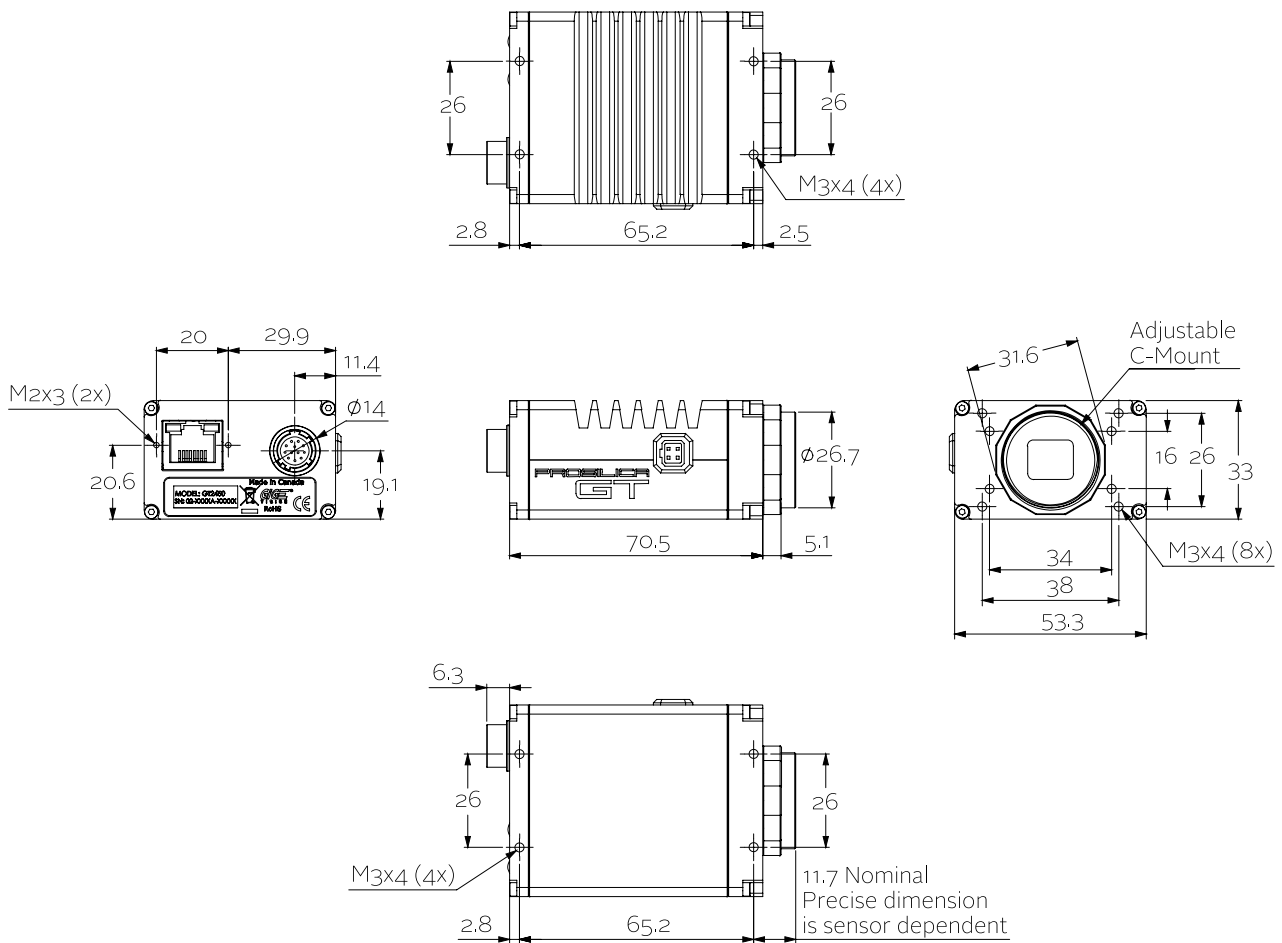

Applications

Prosilica GT1600 is ideal for a wide range of applications including:



- Outdoor imaging
- Traffic imaging / ITS
- Public security and surveillance
- Industrial inspection
- Machine vision
- Military and space applications