

# Prosilica GT

## 1290



- Versatile temperature range for extreme environments
- PTP
- PoE
- P-Iris and DC-Iris lens control

## Description

### 1.2 Megapixel machine vision camera for extreme environments

Prosilica GT1290 is a 1.2 Megapixel camera with a Gigabit Ethernet interface (GigE Vision®). GT1290 incorporates a high-quality Sony ICX445 EXview HAD CCD sensor providing excellent monochrome and color image quality. GT1290 is a rugged camera designed to operate in extreme environments and fluctuating lighting conditions. GT1290 offers Precise iris lens control allowing users to fix the aperture size to optimize depth of field, exposure, and gain without the need for additional control elements.

Options:

- Various IR cut/pass filters and lens mounts

## Specifications

Prosilica GT	1290
Interface	IEEE 802.3 1000BASE-T, IEEE 802.3af (PoE)
Resolution	1280 × 960
Sensor	Sony ICX445
Sensor type	CCD Progressive
Cell size	3.75 μm
Lens mount	C-Mount, CS-Mount
Max frame rate at full resolution	33.3 fps
ADC	14 bit
On-board FIFO	128 Mbyte
<b>Output</b>	
Bit depth	14 (mono) - 12 (color) bit
Mono modes	Mono8, Mono12, Mono12Packed, Mono14
Color modes YUV	YUV411Packed, YUV422Packed, YUV444Packed
Color modes RGB	RGB8Packed, BGR8Packed

<b>Prosilica GT</b>	<b>1290</b>
Raw modes	BayerRG8, BayerRG12, BayerGR12Packed
<b>General purpose inputs/outputs (GPIOs)</b>	
TTL I/Os	1 input, 2 outputs
Opto-isolated I/Os	1 input, 2 outputs
RS-232	1
<b>Operating conditions/dimensions</b>	
Operating temperature	-20°C ... +65°C
Power requirements (DC)	PoE, or 7-25 VDC
Power consumption (@12 V)	3.5 W (PoE) / 2.9 W @ 12 VDC
Mass	211 g
Body dimensions (L × W × H in mm)	86 × 53.3 × 33 (including connectors, w/o tripod and lens)
Regulations	CE, FCC Class A, RoHS (2011/65/EU)

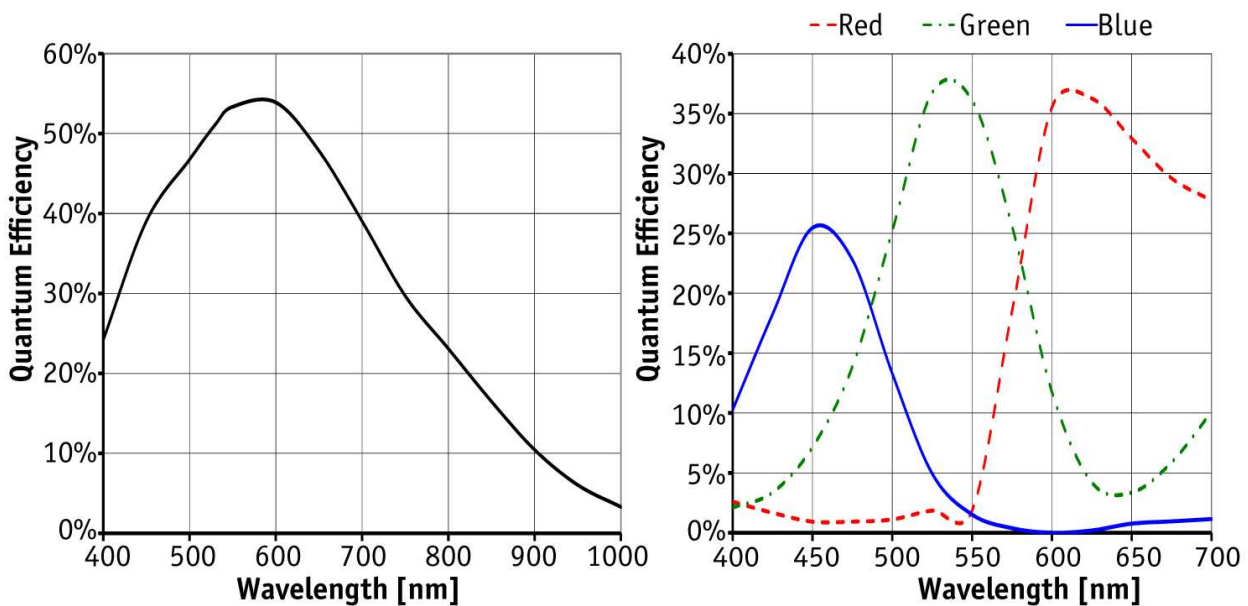

## Features

Prosilica GT1290 features include:

- Precision Time Protocol (IEEE 1588)
- Camera temperature monitoring
- Auto iris (P-Iris and DC-Iris)
- ROI, separate ROI for auto features
- Binning



- Auto gain (manual gain control: 0 to 33 dB)
- Auto exposure (manual exposure control: 12  $\mu$ s to 77.3 s)
- Auto white balance
- LUTs (look-up tables)
- Gamma
- Hue, saturation, color correction
- StreamBytesPerSecond (easy bandwidth control)
- Stream hold
- Sync out modes: Trigger ready, input, exposing, readout, imaging, strobe, GPO
- Event channel
- Chunk data
- Storable user sets

## Technical drawing

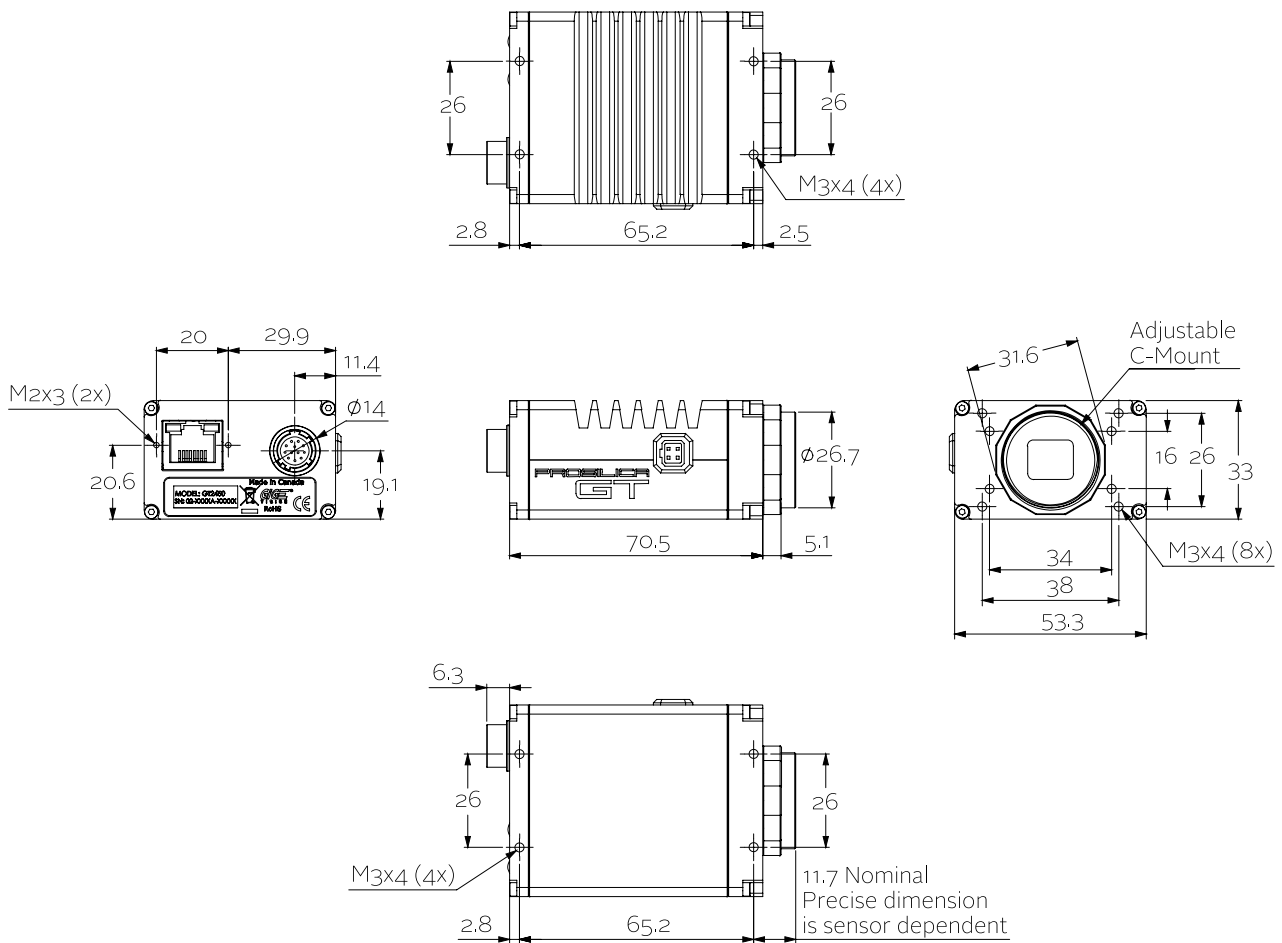

## Applications

Prosilica GT1290 is ideal for a wide range of applications including:



- Outdoor imaging
- Traffic imaging / ITS
- Public security and surveillance
- Industrial inspection
- Machine vision
- Military and space applications