



Guppy PRO

F-031



- Compact VGA camera
- Robust metal housing
- ICX618 CCD sensor
- 123 fps

Description

Small Firewire camera with ICX618 - 1394b

The Guppy PRO F-031B/C is a small 1394b camera with the ICX618 sensor. This EXview HAD CCD sensor is very sensitive both in the visible spectrum and in the NIR (near-infrared) spectrum.

Options

- Various IR cut/pass filters
- White medical housing

Specifications

Guppy PRO	F-031
Interface	IEEE 1394b - 800 Mb/s, 1 port
Resolution	656 × 492
Sensor	Sony ICX618
Sensor type	CCD Progressive
Sensor size	Type 1/4
Cell size	5.6 μm
Lens mount	C-Mount
Max frame rate at full resolution	123 fps
ADC	14 bit
On-board FIFO	0 Mbyte
	Output
Bit depth	8-14 bit
Mono modes	8/12/16
Color modes RGB	RGB8

Guppy PRO	F-031
Raw modes	8/12/16
General purpose inputs/outputs (GPIOs)	
Opto-isolated I/Os	1/3
Operating conditions/dimensions	
Operating temperature	+5 °C ... +45 °C
Power requirements (DC)	8 V - 36 V
Power consumption (@12 V)	<3.5 W
Mass	80 g
Body dimensions (L × W × H in mm)	44.8 × 29 × 29 mm incl. connectors
Regulations	CE, FCC Class B, RoHS

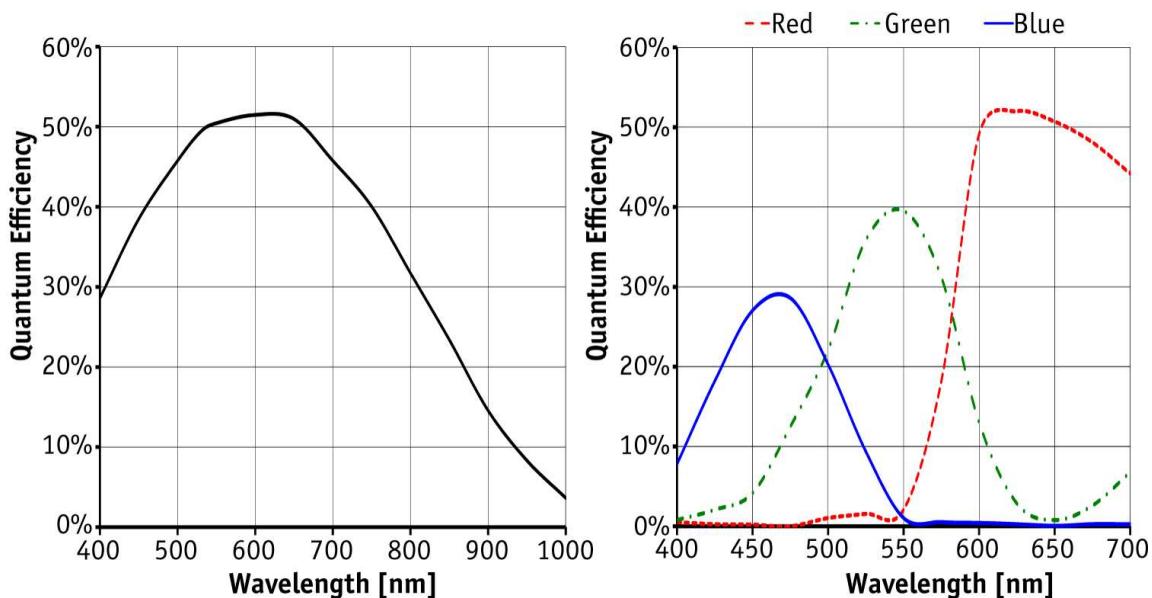

Features

- LUT (look-up table)
- Gamma
- Color correction
- AOI, separate AOI for auto features
- Binning
- Sub-sampling
- Auto gain (manual gain control: 0 to 24.4 dB)
- Auto exposure (75 μ s to 67 s)
- Trigger programmable, level, single, bulk, programmable delay
- Storable user sets

Technical drawing

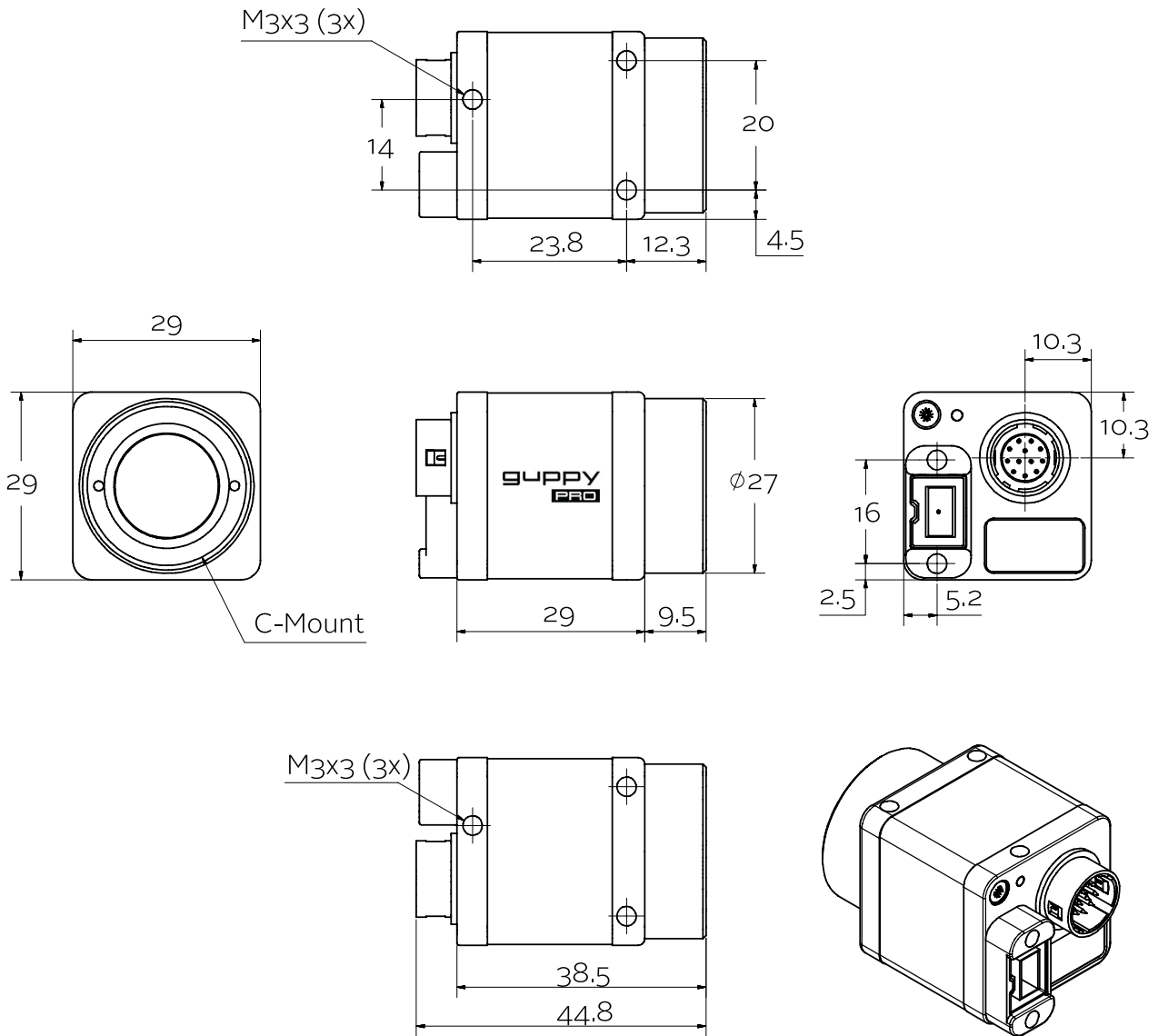



Applications

The Guppy PRO F-031B/C is a fast and sensitive (also NIR sensitive) camera. Its robust, extremely compact design facilitates the integration into your system.

Typical Applications:

- Machine vision
- Robotics
- Semiconductor inspection
- Logistics
- Security and Surveillance
- Pharmaceutical industry
- Food inspection
- ITS/Traffic monitoring