



# Stingray

## F-125



- Versatile 1.2 MP camera
- Advanced feature set
- Many variants
- Excellent image quality

## Description

Industrial camera, Sony EXview HAD CCD sensor ICX445

The Stingray F-125B/C is equipped with the Sony ExView HAD CCD sensor ICX445 and has an extra high sensitivity. At full resolution, it runs at 30 fps. Higher frame rates can be reached by a smaller AOI, binning (b/w) or sub-sampling.

Options

- 1394b connectors: 2 x copper (daisy chain) or 1 x GOF, 1 x copper, Hirose power: out
- Various IR cut/pass filters, various lens mounts
- Angled head, compact housing version, board level version, white medical housing

## Specifications

Stingray	F-125
Interface	IEEE 1394b - 800 Mb/s, 2 ports, daisy chain, fiber optic (GOF) optional
Resolution	1292 × 964
Sensor	Sony ICX445
Sensor type	CCD Progressive
Sensor size	Type 1/3
Cell size	3.75 μm
Lens mount	C
Max frame rate at full resolution	30 fps
ADC	14 bit
On-board FIFO	32 Mbyte
	<b>Output</b>
Bit depth	8-14 bit

Stingray	F-125
Mono modes	Mono8, Mono12, Mono16
Color modes RGB	RGB8
Raw modes	Raw8, Raw12, Raw16
<b>General purpose inputs/outputs (GPIOs)</b>	
Opto-isolated I/Os	2 inputs, 4 outputs
RS-232	1
<b>Operating conditions/dimensions</b>	
Power requirements (DC)	8 V - 36 V
Power consumption (@12 V)	<4 W
Mass	92 g
Body dimensions (L × W × H in mm)	72.9 × 44 × 29 mm including connectors, w/o tripod and lens
Regulations	CE, FCC Class B, RoHS

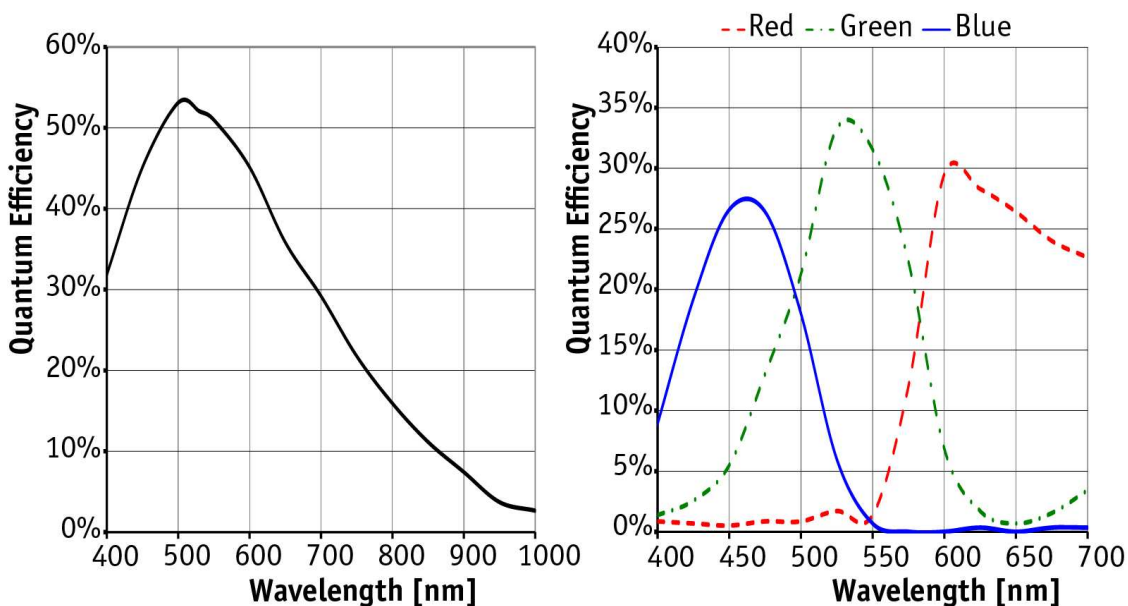

## Features

- High SNR mode (up to 24 dB better signal-to-noise ratio)
- Low-noise binning mode
- Shading correction
- Defect pixel correction
- ROI, separate ROI for auto features
- Binning
- Decimation



- Auto gain (manual gain control: 0 to 24.4 dB)
- Auto exposure (25  $\mu$ s to 67 s)
- Auto white balance
- LUT (look-up table)
- Hue, saturation
- Color correction
- Local color anti-aliasing
- Reverse X/Y
- Deferred image transport
- Trigger programmable, level, single, bulk, programmable delay
- Sequence mode (changes the camera settings on the fly)
- SIS (secure image signature, time stamp for trigger, frame count etc.)
- Storable user sets

## Technical drawing

### 2 x 1394b copper

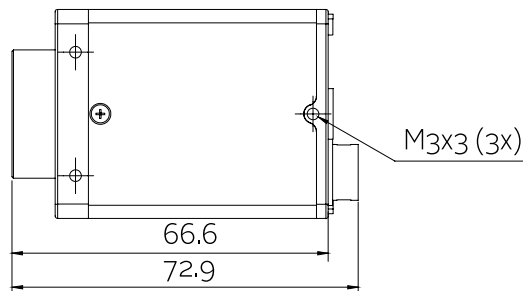
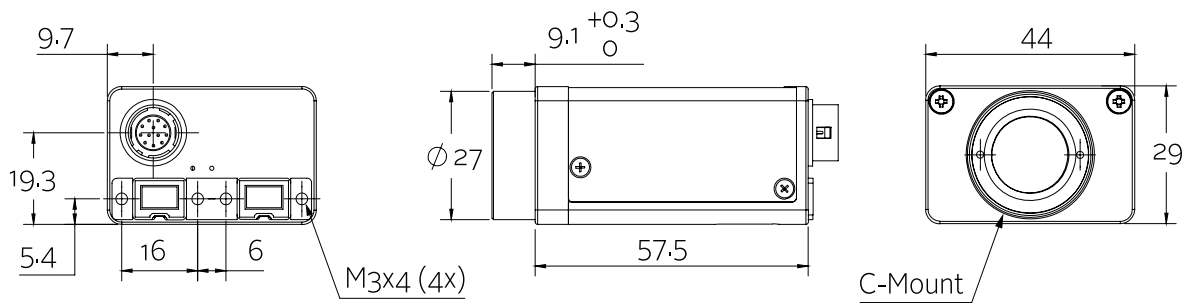
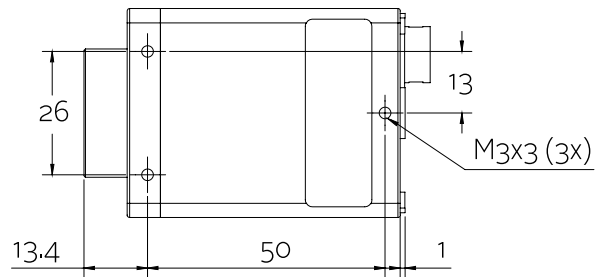

## Applications

Stingray F-125B/C cameras incorporate the Sony ExView HAD sensor ICX445 (very high sensitivity). Furthermore, its smart functions like the High SNR mode enhance the image quality especially in low light situations. This industrial camera is ideally suited for:

- Industrial inspection and automation
- Logistics
- Science and research
- Healthcare and medical (light gray housing available)
- Multimedia, entertainment and sports
- ITS (Intelligent traffic solutions)
- ... and many more

Additionally, it is ideally suited for:

- Demanding OEM camera applications (board level versions with separate sensor board available on request)
- Daisy chaining (two copper connectors)
- Long cables - 400 meters and more without additional repeaters (glass optical fiber version: Stingray F-125B/C fiber)