



Stingray

F-504



- Versatile 5 MP camera
- Advanced feature set
- Many variants
- Excellent image quality

Description

High performance 1394b camera - 5 Megapixel - 9 fps

The Stingray F-504B/C is equipped with a 5 Megapixel CCD sensor (ICX655). At full resolution, this 1394b camera runs at 9 fps. Higher frame rates can be reached by a smaller AOI, binning (b/w) or sub-sampling. Options

- 1394b connectors: 2 x copper (daisy chain) or 1 x GOF, 1 x copper, Hirose power: out
- Various IR cut/pass filters, various lens mounts
- Angled head, compact housing version, board level version, white medical housing

Specifications

Stingray	F-504
Interface	IEEE 1394b - 800 Mb/s, 2 ports, daisy chain, fiber optic (GOF) optional
Resolution	2452 × 2056
Sensor	Sony ICX655
Sensor type	CCD Progressive
Sensor size	Type 2/3
Cell size	3.45 μm
Lens mount	C
Max frame rate at full resolution	9 fps
ADC	14 bit
On-board FIFO	64 Mbyte
	Output
Bit depth	8-14 bit

Stingray	F-504
Mono modes	Mono8, Mono12, Mono16
Color modes RGB	RGB8
Raw modes	Raw8, Raw12, Raw16
General purpose inputs/outputs (GPIOs)	
Opto-isolated I/Os	2 inputs, 4 outputs
RS-232	1
Operating conditions/dimensions	
Power requirements (DC)	8 V - 36 V
Power consumption (@12 V)	<4 W
Mass	92 g
Body dimensions (L × W × H in mm)	72.9 × 44 × 29 mm including connectors, w/o tripod and lens
Regulations	CE, FCC Class B, RoHS

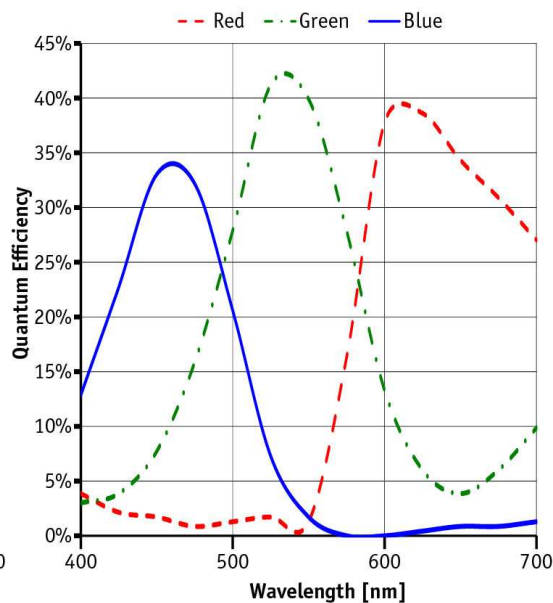
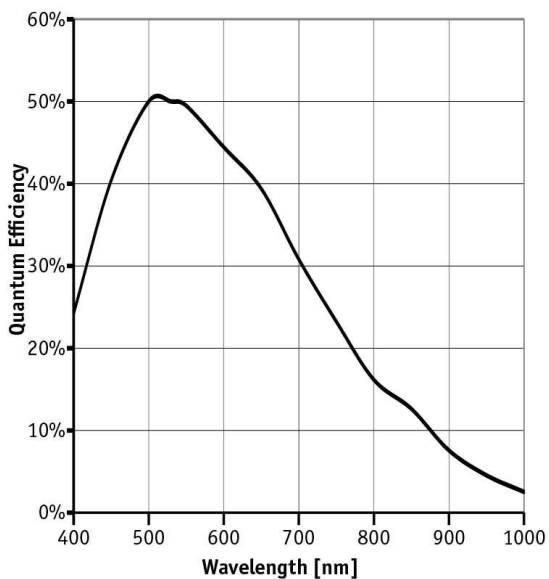

Features

- High SNR mode (up to 24 dB better signal-to-noise ratio)
- Low-noise binning mode
- Shading correction
- Defect pixel correction
- ROI, separate ROI for auto features
- Binning
- Decimation



- Auto gain (manual gain control: 0 to 24.4 dB)
- Auto exposure (42 μ s to 67 s)
- Auto white balance
- LUT (look-up table)
- Hue, saturation
- Color correction
- Local color anti-aliasing
- Reverse X/Y
- Deferred image transport
- Trigger programmable, level, single, bulk, programmable delay
- Sequence mode (changes the camera settings on the fly)
- SIS (secure image signature, time stamp for trigger, frame count etc.)
- Storable user sets

Technical drawing

2 x 1394b copper

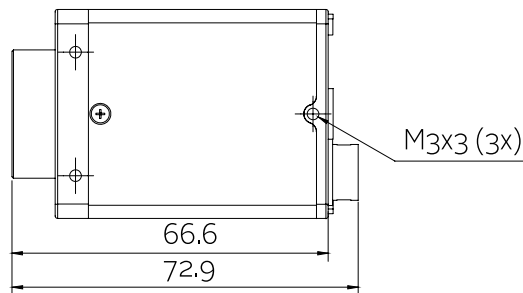
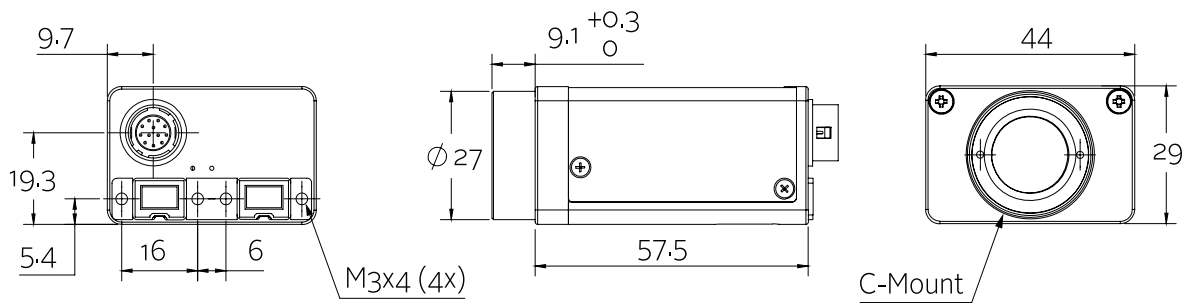
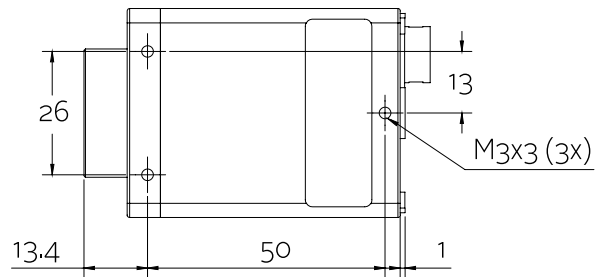

Applications

The Stingray F-504B/C meets high demands. Its brilliant image quality can be enhanced by several image pre-processing functions. Due to the modular design, customization is easy and cost-effective. This 5 Megapixel camera fits for:

- Intelligent traffic systems
- Industrial inspection and automation
- Logistics
- Science and research
- Microscopy
- Healthcare and medical (light gray housing available)
- Multimedia and entertainment
- ... and many more

Additionally, it is ideally suited for:

- Demanding OEM camera applications (board level versions with separate sensor board available on request)
- Daisy chaining (two copper connectors)
- Long cables - 400 meters and more without additional repeaters (fiber version)