

Prosilica GT

2050 NIR



- Versatile temperature range for extreme environments
- CMOSIS CMOS sensor
- PTP and PoE
- P-Iris and DC-Iris lens control

Description

4 Megapixel CMOS NIR enhanced camera for extreme environments - fast frame rates

Prosilica GT2050 NIR is a 4 Megapixel camera equipped with a NIR optimized variant of CMOSIS CMV4000 sensor. At 900 nm this sensor offers double the quantum efficiency, an increase from 8% to 16% absolute. GT2050 NIR is a rugged camera designed to operate in extreme environments and fluctuating lighting conditions. It offers Precise iris lens control allowing users to fix the aperture size to optimize depth of field, exposure and gain without the need for additional control elements.

Options:

- Various lens mounts

Specifications

Prosilica GT	2050 NIR
Interface	IEEE 802.3 1000BASE-T, IEEE 802.3af (PoE)
Resolution	2048 × 2048
Sensor	CMOSIS CMV4000 NIR
Sensor type	CMOS Progressive
Cell size	5.5 μm
Lens mount	C-Mount
Max frame rate at full resolution	28.6 fps
ADC	12 bit
On-board FIFO	128 Mbyte
Output	
Bit depth	8/12 bit
Mono modes	Mono8, Mono12, Mono12Packed
General purpose inputs/outputs (GPIOs)	
TTL I/Os	1 input, 2 outputs

Prosilica GT	2050 NIR
Opto-isolated I/Os	1 input, 2 outputs
RS-232	1
Operating conditions/dimensions	
Operating temperature	-20°C ... +65°C
Power requirements (DC)	PoE, or 7–25 VDC
Power consumption (@12 V)	4.3 W (PoE) / 3.5 W @ 12 VDC
Mass	210 g
Body dimensions (L × W × H in mm)	86 × 53.3 × 33 mm including connectors, w/o tripod and lens
Regulations	CE, FCC Class A, RoHS (2011/65/EU)

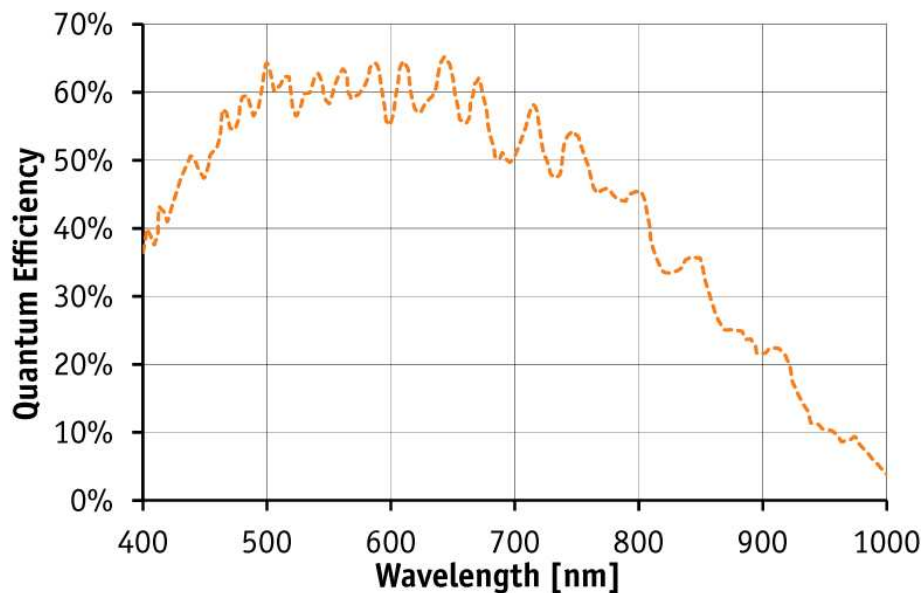

Features

Prosilica GT2050 NIR features include:

- Precision Time Protocol (IEEE 1588)
- Camera temperature monitoring
- Defect masking
- Auto iris (P-Iris and DC-Iris)
- ROI, separate ROI for auto features
- Auto gain (manual gain control: 0 to 26 dB)
- Auto exposure (manual exposure control: 34 μ s to 126.2 s)
- Auto white balance



- Gamma
- Hue, saturation, color correction
- StreamBytesPerSecond (easy bandwidth control)
- Stream hold
- Sync out modes: Trigger ready, input, exposing, readout, imaging, strobe, GPO
- Event channel
- Chunk data
- Storable user sets

Technical drawing

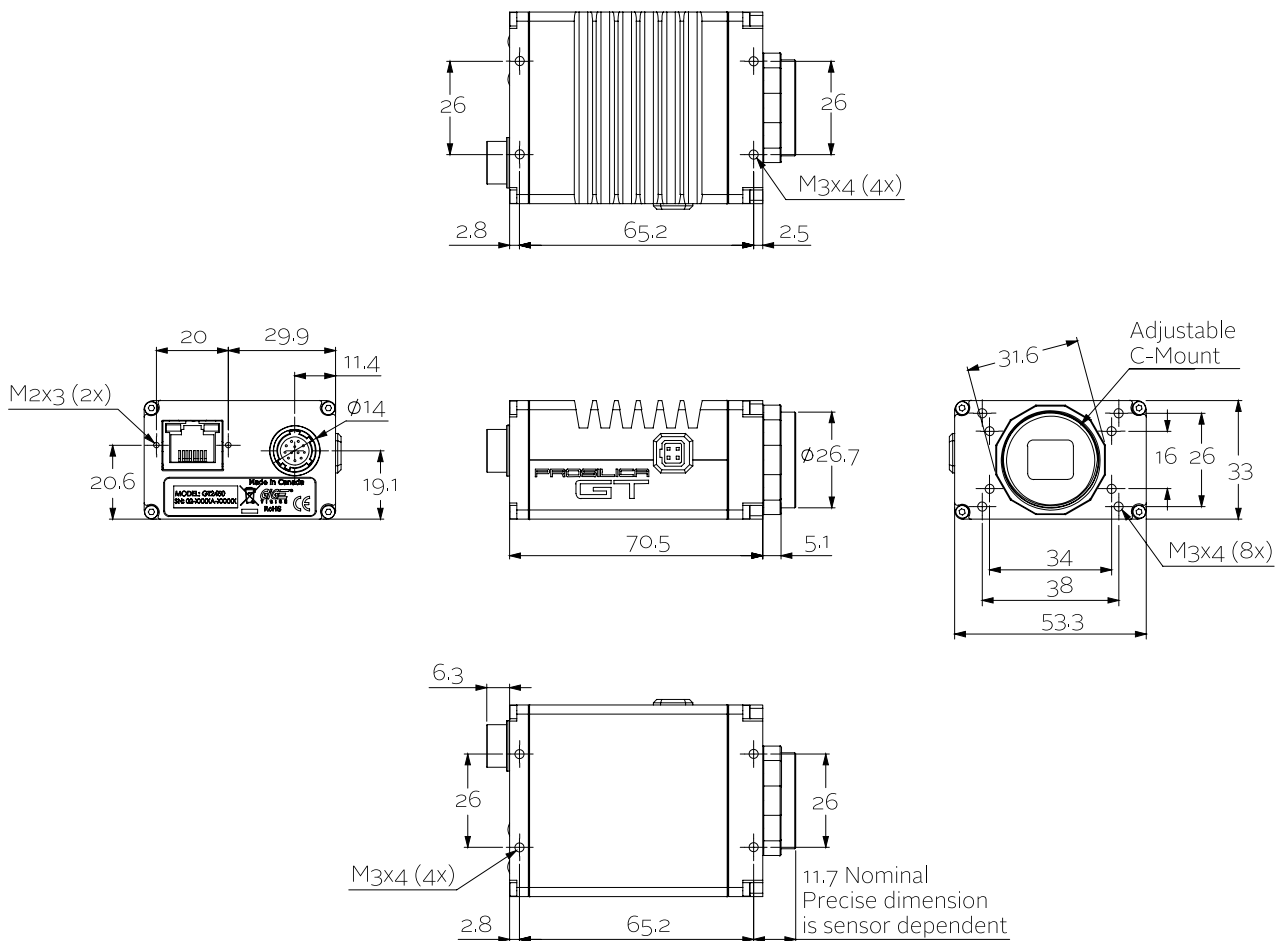

Applications

Prosilica GT2050 NIR is ideal for a wide range of applications including:



- Outdoor imaging
- Traffic imaging / ITS
- Public security and surveillance
- Industrial inspection
- Machine vision
- Microscopy
- Medical and healthcare
- ... and many more