

Manta G-223 NIR



- NIR enhanced CMOS sensor
- PoE optional
- Angled head and boardlevel variants
- Video-iris lens control

Description

GigE camera with CMOSIS CMV2000, NIR optimized, global shutter

Manta G-223B NIR is an NIR optimized GigE camera with a 2/3" CMOSIS CMV2000 sensor. Manta G-223B NIR offers several modular options (examples include PoE, board level and angled head versions, filter selections for improving the image quality, and OEM branding).

Options

- PoE (Power over Ethernet)
- Various IR cut/pass filters and lens mounts
- Angled head, board level version, white medical housing

Specifications

Manta	G-223 NIR
Interface	IEEE 802.3 1000BASE-T, IEEE 802.3af (PoE) optional
Resolution	2048 × 1088
Sensor	CMOSIS CMV2000
Sensor type	CMOS Progressive
Sensor size	Type 2/3
Cell size	5.5 μm
Lens mount	C-Mount
Max frame rate at full resolution	53.7 fps
ADC	12 bit
On-board FIFO	128 Mbyte
Output	
Bit depth	8-12 bit

Manta	G-223 NIR
Mono modes	Mono8, Mono12Packed, Mono12
General purpose inputs/outputs (GPIOs)	
Opto-isolated I/Os	2 inputs, 2 outputs
RS-232	1
Operating conditions/dimensions	
Operating temperature	+5 °C ... +45 °C
Power requirements (DC)	PoE, or 8-30 VDC
Power consumption (@12 V)	3.1 W (PoE) / 2.7 W (non-PoE)
Mass	200 g (PoE) / 190 g (non-PoE)
Body dimensions (L × W × H in mm)	86.4 × 44 × 29 mm incl. connectors
Regulations	CE, FCC Class B, RoHS

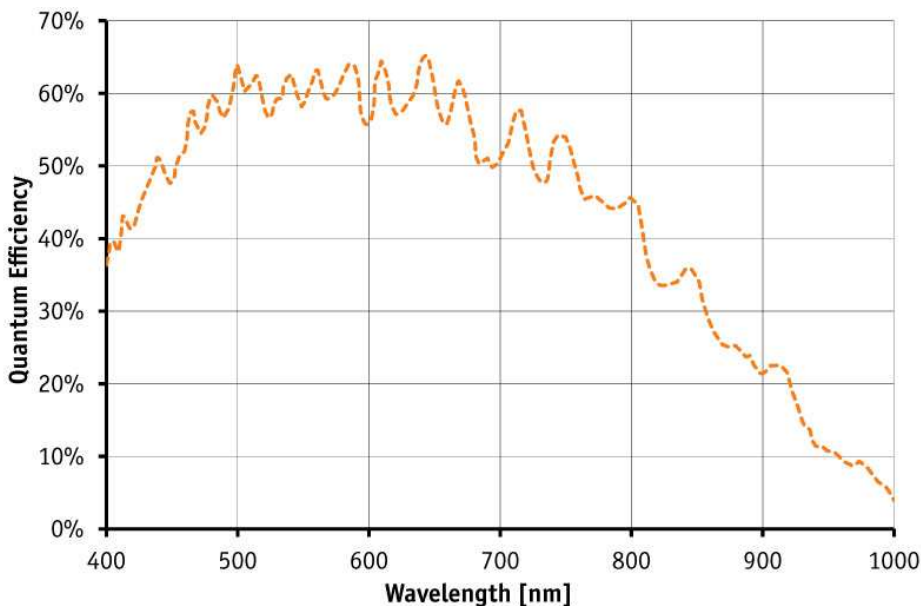

Features

- Precision Time Protocol (IEEE 1588)
- Camera temperature monitoring
- Video-type auto iris
- ROI, separate ROI for auto features
- Decimation
- Auto gain (manual gain control: 0 to 26 dB)
- Auto exposure (18 μs to 126 s)
- LUTs (look-up tables)
- Gamma



- StreamBytesPerSecond (easy bandwidth control)
- Stream hold
- Sync out modes: Trigger ready, input, exposing, readout, imaging, strobe, GPO
- Event channel
- Chunk data
- Storable user sets

Technical drawing

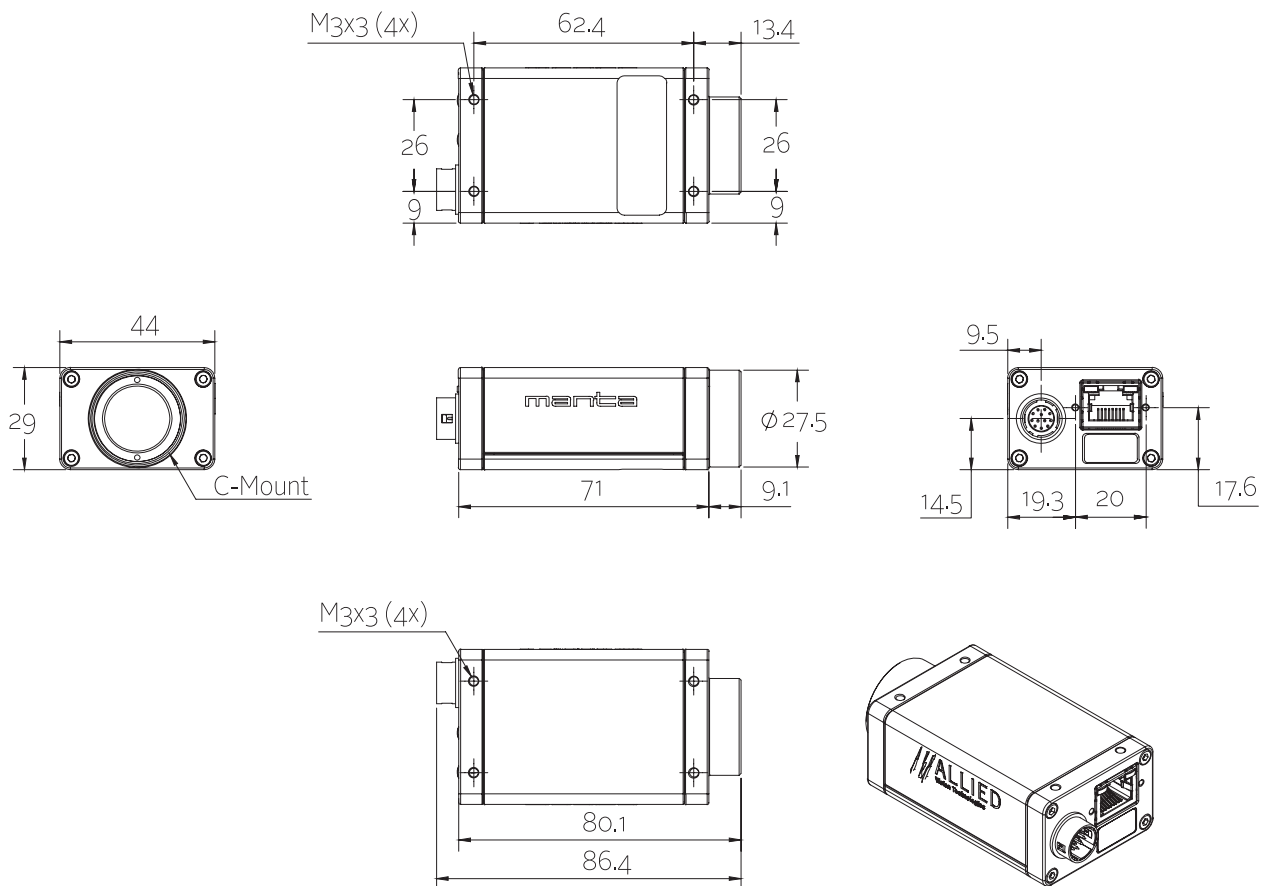

Applications

Manta G-223B NIR is a robust, flexible NIR optimized camera with a sensitive CMOSIS CMV2000 sensor.



Typical applications:

- Multimedia and entertainment
- Machine vision
- Security and surveillance
- Metrology and inspection systems
- Industrial image processing