

Mako G

G-503



- Ultra-compact (60.5 × 29 × 29 mm)
- Latest Aptina CMOS sensor
- 14 fps @ 5 Megapixel
- Switchable shutter modes

Description

GigE camera with Aptina CMOS sensor

Mako G-503B/C is an industrial GigE camera with the Aptina MT9P031 (monochrome) / MT9P006 (color) sensor. Mako G cameras have the same compact form factor and the same mounting positions as many analog cameras. All models include PoE, three opto-isolated outputs, and a 64 MB FIFO image buffer. The image quality profits from the precisely aligned sensors.

Options

- Various IR cut/pass filters, protection glass, various lens mounts
- White medical housing

Specifications

Mako G	G-503
Interface	IEEE 802.3 1000BASE-T, IEEE 802.3af (PoE)
Resolution	2592 × 1944
Sensor	Aptina MT9P031 / MT9P006
Sensor type	CMOS Progressive
Sensor size	Type 1/2.5
Cell size	2.2 μm x 2.2 μm
Lens mount	C/CS-Mount
Max frame rate at full resolution	14 fps
ADC	12 bit
On-board FIFO	64 Mbyte
	Output
Bit depth	8/12 bit

Mako G	G-503
Mono modes	Mono8, Mono12, Mono12Packed
Color modes YUV	YUV411Packed, YUV422Packed, YUV444Packed
Color modes RGB	RGB8Packed, BGR8Packed
Raw modes	BayerGR8, BayerGR12Packed, BayerGR12
General purpose inputs/outputs (GPIOs)	
Opto-isolated I/Os	1 input, 3 outputs
Operating conditions/dimensions	
Operating temperature	+5°C to +45°C (housing temperature)
Power requirements (DC)	PoE / 12 V - 24 V
Power consumption (@12 V)	2.2 W (PoE) / 2.0 W (non-PoE)
Mass	80 g
Body dimensions (L × W × H in mm)	60.5 × 29 × 29 mm, incl. connectors
Regulations	CE, FCC Class B, RoHS

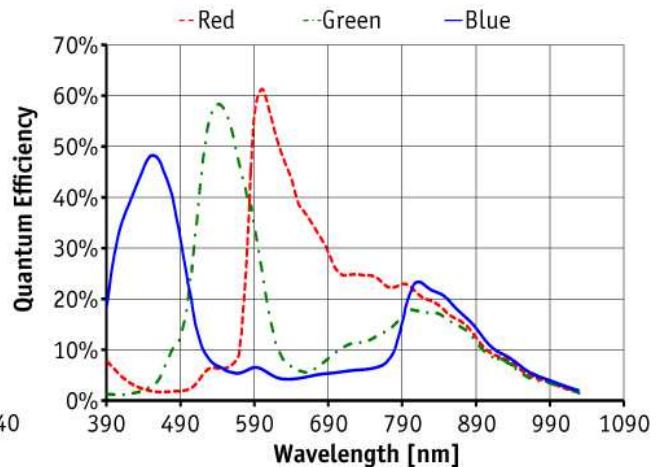
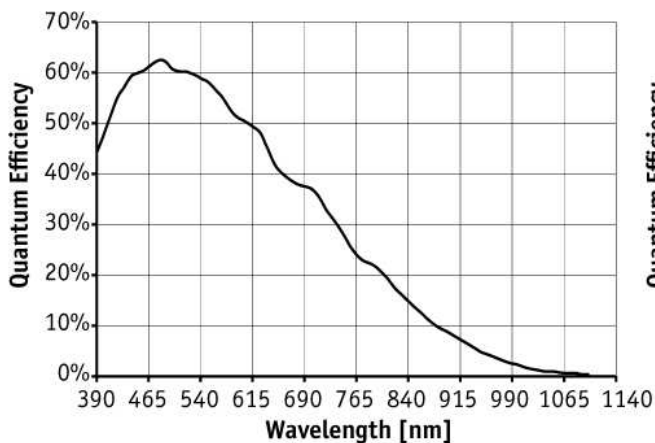

Features

- Camera temperature monitoring
- Switchable Rolling/GlobalReset shutter modes
- Pixel defect masking
- ROI, separate ROI for auto features
- Binning
- Decimation
- Auto gain (manual gain control: 0 to 24 dB)



- Auto exposure
- Auto white balance
- LUTs (look-up tables)
- Gamma
- Hue, saturation, color correction
- ReverseX/Y
- StreamBytesPerSecond (easy bandwidth control)
- Stream hold
- Sync out modes: Trigger ready, input, exposing, readout, imaging, strobe, GPO
- Event channel
- Chunk data
- Storable user sets

Technical drawing

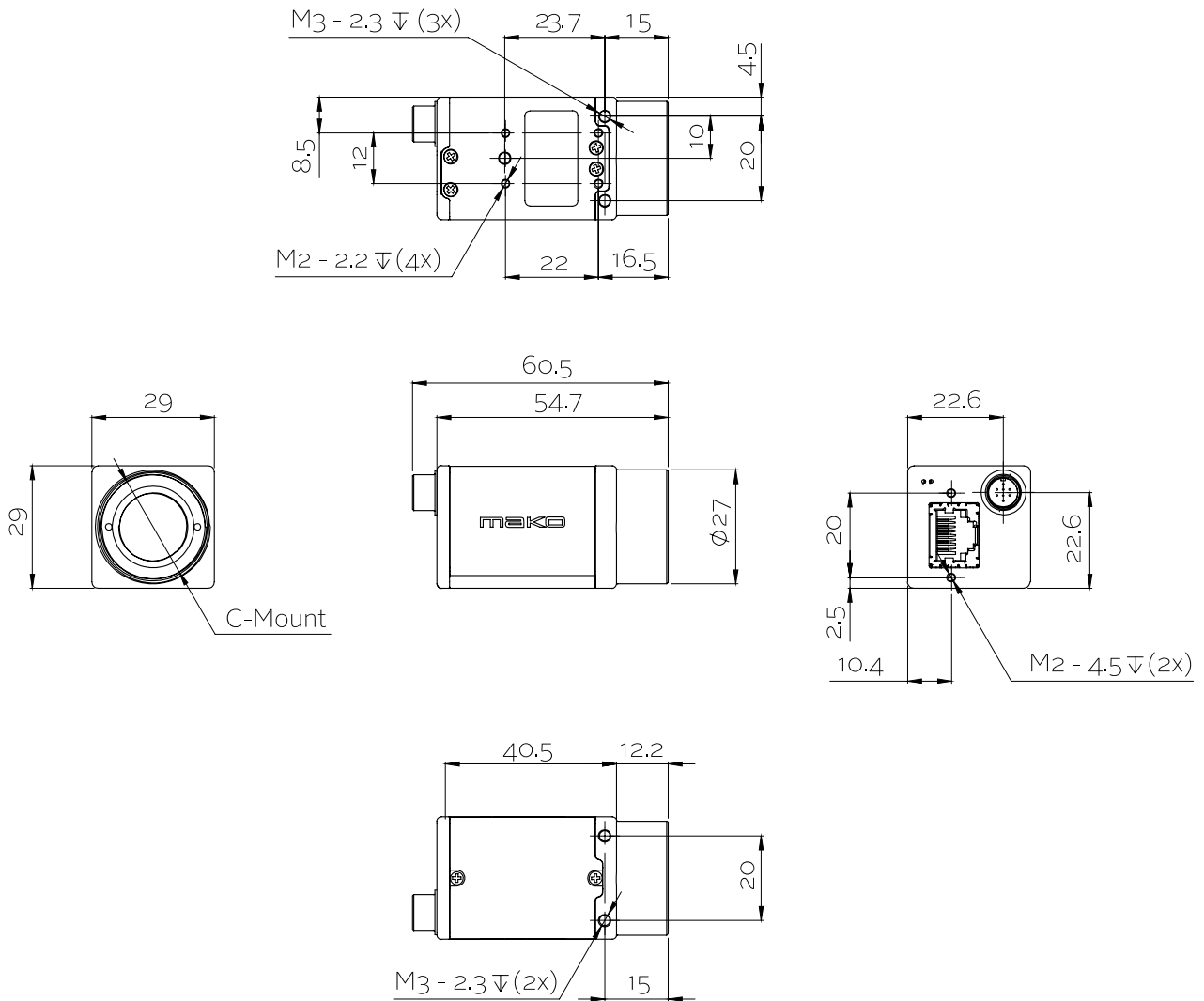



Applications

Mako G is an inexpensive industrial GigE camera with a compact form factor. It is suitable for all typical machine vision applications:

- Robotics
- Quality control
- Inspection, surveillance
- Industrial imaging
- Machine vision
- Logistics