

NEW

Liquid Crystal Based Spatial Light Modulator Embedded module (For OEM) / SLM-30

The SLM-30 is a spatial light modulator for high-power lasers that is compatible with 200 W (watt)-class lasers by optimizing the liquid crystal and heat dissipation structure. The LCOS-SLM head and drive circuit are connected by a flexible cable for easy integration into equipment. The LCOS-SLM head is equipped with a water-cooled heat sink for high cooling performance.

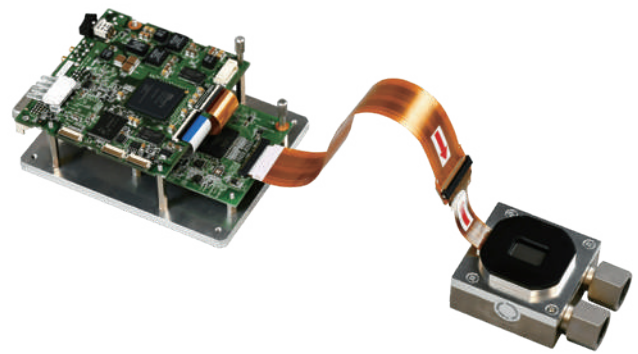

*Circuit board fixing jig is not included.

Features

- ▶ Center Wavelength 532, 800, 1064 nm
- ▶ High-power durability up to CW 200 Watts
- ▶ Small-sized and reasonable price for equipment integration
- ▶ Panel resolution beyond Full HD (1920 x 1200 pixels)
- ▶ High Phase Resolution 10-bit (1024) Gray Level
- ▶ Ultra Low Phase Noise ~0.003mrad.(Typ.)

Block diagram

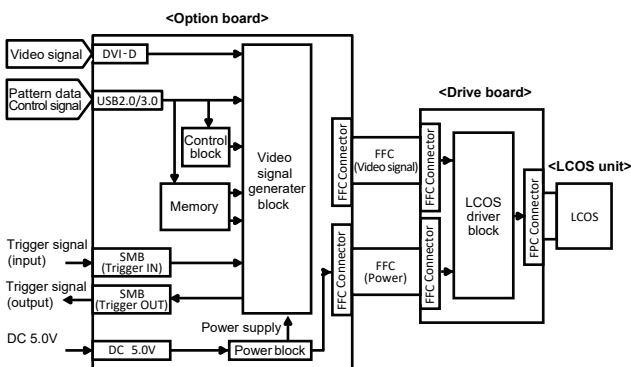

Applications

- ▶ Laser Processing
- ▶ 3D-Printing
- ▶ IC Trimming
- ▶ Wavefront adaptive optics
- ▶ Pulse / Spectral shaping

Wavelength option

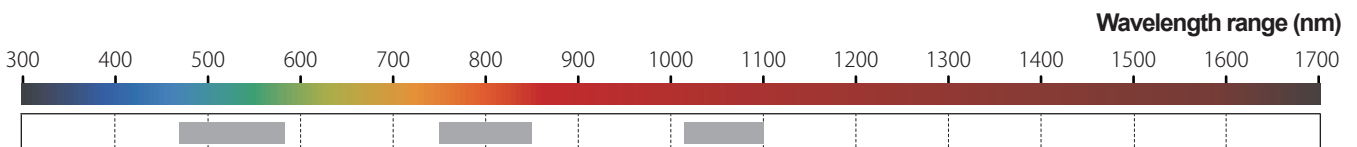

Specifications

Item		min	max	Units	Notes
Wavelength range	Type 01	485	580	nm	
	Type 02	750	850		
	Type 03	1020	1110		
Phase depth	Type 01	2π	-	rad.	At 580 nm
	Type 02				At 850 nm
	Type 03				At 1110 nm
Response time ¹⁾ (Tr / Tf)	Type 01	37 / 72		ms	Tr: Rise time between 10% and 90% levels in a phase change of 0 to 2π rad at 25°C. Tf: Fall time between 90% and 10% levels in a phase change of 0 to 2π rad at 25°C.
	Type 02	171 / 324			
	Type 03	163 / 330			
AR coat reflectance		-	1.0	%	Angle of incidence = 0 degree
Frame rate		60		Hz	
Panel reflectivity		Typ. >92		%	Depending on specified wavelength range
Aperture ratio		95		%	
Pixel size / pitch		7.8 / 8.0		μm	
Panel size		(H)15.36 x (V)9.60		mm	Active area
Panel resolution ²⁾		(H)1920 x (V)1200		pixel	
LCOS drive frequency		1200		Hz	
Phase stability		Typ. < 0.003π		rad.	
Gray level		10 (1024 levels)		bit	
Optical power handling ³⁾		-	200	W/cm ²	1064 nm CW
Water flow		1~10		L/min	15~25°C(Cooling water temperature)
Water inlet and outlet		Pipe fitting Rc(PT) 3/8 inch female		-	
Operation temperature		15	35	°C	No condensation
Storage temperature		0	40	°C	No condensation
Interface		DVI*/ USB 3.0 / Trigger IN, OUT (SMB)		-	*10-bit using RGB 8-bit, 3 colors
Control software		GUI software and SDK for Windows		-	C#, Python, Matlab, Labview

- 1) Response time is a typical value and is not affected by frame rate.
- 2) Specification on the defect pixels are no object.
- 3) The value is not guaranteed.

Dimensions Unit [mm]

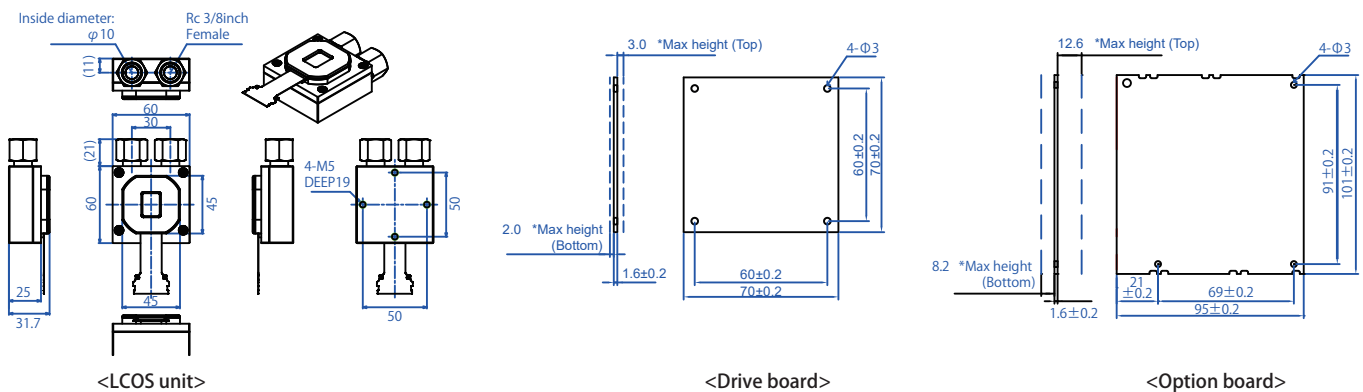

www.santec.com

2023© Santec AOC corporation santec reserves the right to make changes in equipment design, components or specifications without notice.



Santec Japan Corporation

5823 Ohkusa-Nenjozaka, Komaki, Aichi 485-0802, Japan Tel. +81-568-79-3536 Fax +81-568-79-1718

Santec USA Corporation

400 Kelby Street Suite 1501, Fort Lee, NJ 07024, USA Toll Free +1-800-726-8321(santec-1) Tel. +1-201-488-5505 Fax +1-201-488-7702

Santec Europe Ltd.

99 Park Drive Milton Park, Abingdon Oxfordshire, OX14 4RY, U.K. Tel. +44-20-3176-1550

Santec (Shanghai) Co., Ltd.

21F Room H, Hua Du Bldg., No.838 Zhangyang Road, Pudong District, Shanghai 200122 China Tel: +86-21-58361261, Fax: +86-21-58361263