

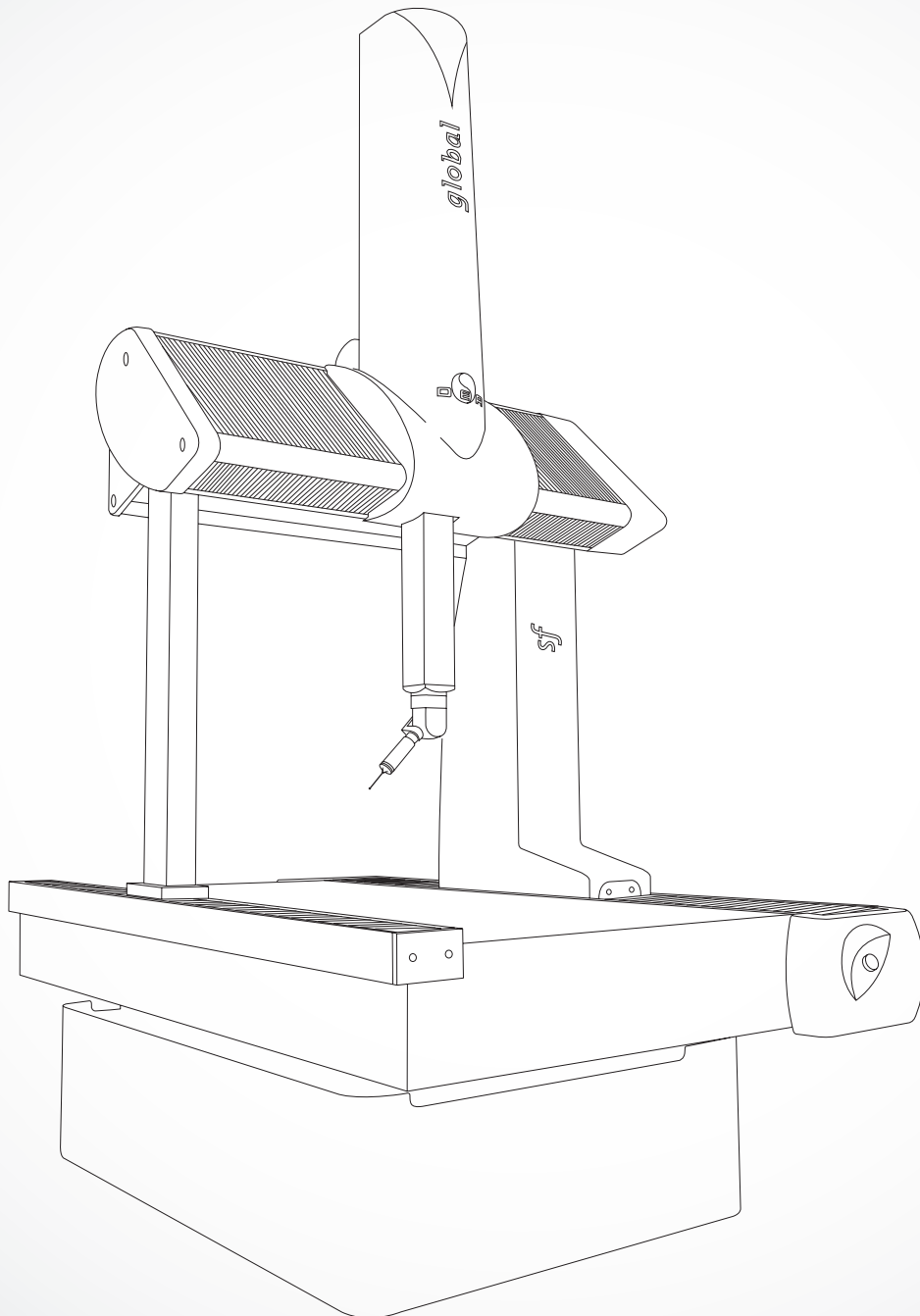

DEA GLOBAL SILVER SF



DEA GLOBAL Silver SF 07.07.05, 07.10.05, 07.10.07

Probe Configuration	Temperature Range 18 ÷ 22 °C			Temperature Range 16 ÷ 26 °C			Temperature Range 15 ÷ 30 °C		
	$E_{0,MPE}/E_{150,MPE}$	$P_{FTU,MPE}$	$MPE_{THP/t}$	$E_{0,MPE}/E_{150,MPE}$	$P_{FTU,MPE}$	$MPE_{THP/t}$	$E_{0,MPE}/E_{150,MPE}$	$P_{FTU,MPE}$	$MPE_{THP/t}$
HP-S-X3C	1.5 + L/333	1.6	2.9/45	1.5 + L/294	1.6	2.9/45	1.5 + L/263	1.6	2.9/45
HP-S-X1C	1.5 + L/333	1.6	2.9/45	1.5 + L/294	1.6	2.9/45	1.5 + L/263	1.6	2.9/45
HH-A, HH-AS/HP-S-X1S, H	1.5 + L/333	1.6	2.9/45	1.5 + L/294	1.6	2.9/45	1.5 + L/263	1.6	2.9/45
HH-A, HH-AS/TP200	1.7 + L/333	1.9	–	1.7 + L/294	1.9	–	1.7 + L/263	1.9	–
HH-A, HH-AS/HP-T, HP-TM	1.9 + L/333	2.0	–	1.9 + L/294	2.0	–	1.9 + L/263	2.0	–

Probe Configuration	$R_{O,MPL}$
HP-S-X3C	1.4
HP-S-X1C	1.4
HH-A, HH-AS/HP-S-X1S, H	1.4
HH-A, HH-AS/TP200	1.9
HH-A, HH-AS/HP-T, HP-TM	1.9

NOTE: $E_{0,MPE}/E_{150,MPE}$ specifications are to be formally understood as $E_{0,MPE}^*/E_{150,MPE}^*$ for the case where non-normal CTE material calibrated test lengths are used.

Probe Configuration for performance test:

- HP-S-X3C: stylus length 60 mm, tip diameter 5 mm
- HP-S-X1C: stylus length 20 mm, tip diameter 5 mm
- HP-S-X1S: without extension, stylus length 50 mm, tip diameter 5 mm
- HP-S-X1H: with an extension of 100 mm, stylus length 20 mm, tip diameter 5 mm
- TP200: Standard Force Module, stylus length 10 mm, tip diameter 4 mm
- HP-T: Standard Force, stylus length 10 mm, tip diameter 4 mm
- HP-TM: Standard Force Module, stylus length 10 mm, tip diameter 4 mm

Dynamics:

- Max. 3D Speed. 3D: 516 mm/s
- Max. 3D Accel.: 1700 mm/s² (1400 mm/s² with LSP-X3c)
- Max. Scanning Speed : 300 mm/s

Performance data are valid if the following specification are met:

Temperature Range	18 ÷ 22 °C
Max. air temperature variation	1 °C/h - 2 °C/24h
Max. air temperature variation	1 °C/m
Temperature Range	16 ÷ 26 °C
Max. air temperature variation	1 °C/h - 5 °C/24h
Max. air temperature variation	1 °C/m
Temperature Range	15 ÷ 30 °C (*)
Max. air temperature variation	1 °C/h - 5 °C/24h
Max. air temperature variation	1 °C/m

(*) Accuracy values under the conditions below are available on request:

Temperature Range	15 ÷ 30 °C
Max. air temperature variation	2 °C/h - 10 °C/24h
Max. air temperature variation	1 °C/m

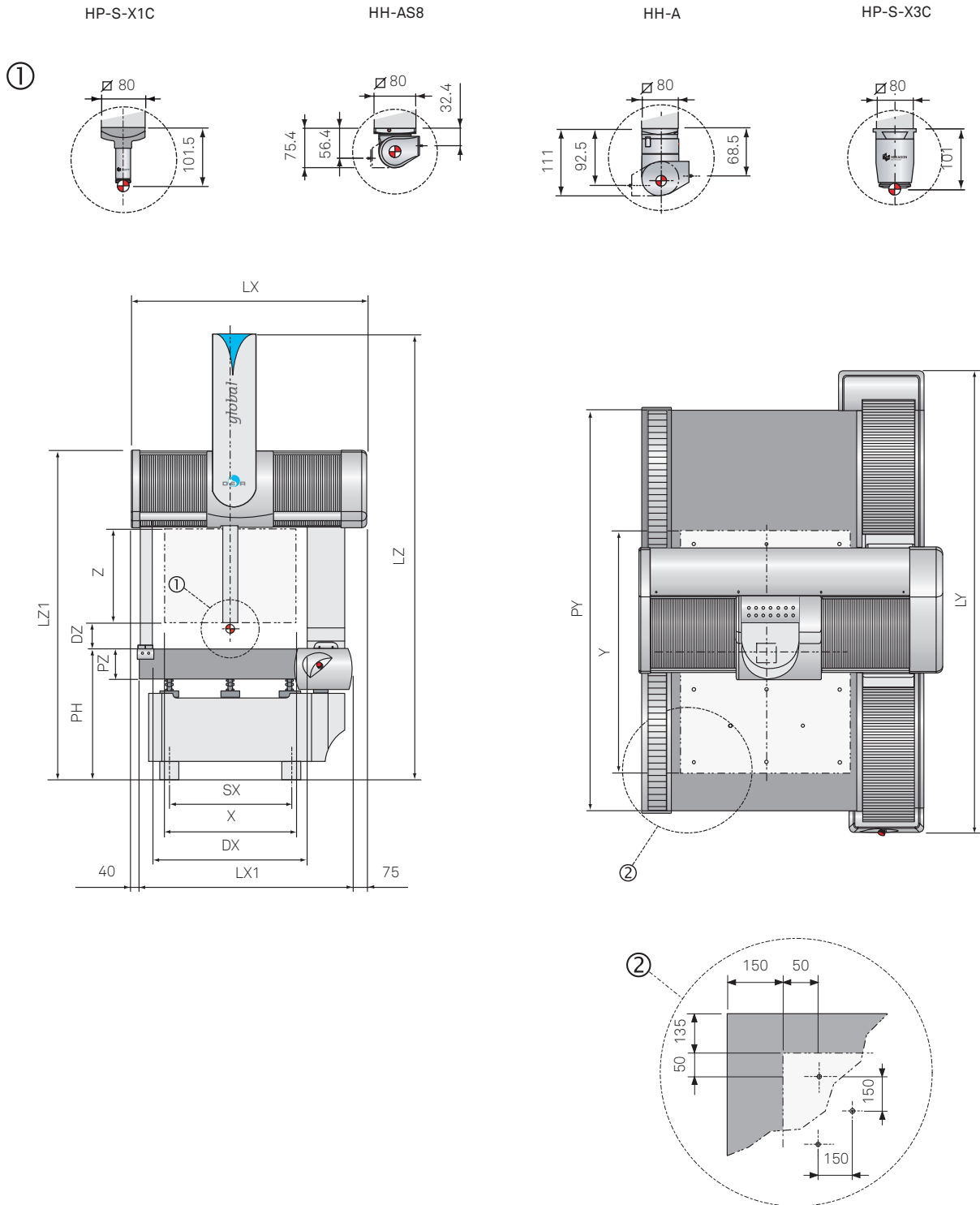

NOTE: ISO 10360-2 test with maximum part weight performed as an option upon request only.

Models	Strokes (mm)			Overall Dimensions (mm)						Surface Plate (mm)			Day lights (mm)		Max. Part Weight (kg)	CMM Weight (kg)
	X	Y	Z	LX	LX1	LY	LZ	LZ1	SX	PZ	PH	PY	DX	DZ		
07.07.05	700	700	500	1250	1161	1610	2376	1754	650	180	700	1350	803	140	900	950
07.10.05	700	1000	500	1250	1161	1910	2376	1754	650	200	700	1650	803	140	900	1235
07.10.07	700	1000	660	1250	1161	1910	2696	1914	650	200	700	1650	803	140	900	1255

Probe Configuration	Temperature Range 18 ÷ 22 °C			Temperature Range 16 ÷ 26 °C			Temperature Range 15 ÷ 30 °C		
	$E_{0,MPE}/E_{150,MPE}$	$P_{FTU,MPE}$	$MPE_{THP/\tau}$	$E_{0,MPE}/E_{150,MPE}$	$P_{FTU,MPE}$	$MPE_{THP/\tau}$	$E_{0,MPE}/E_{150,MPE}$	$P_{FTU,MPE}$	$MPE_{THP/\tau}$
DEA GLOBAL Silver SF 09.xx.08									
HP-S-X3C/X5	1.4 + L/333	1.4	2.5/45	1.4 + L/285	1.4	2.5/45	1.4 + L/256	1.4	2.5/45
HH-A, HH-AS/HP-S-X1S, H	1.4 + L/333	1.4	2.5/45	1.4 + L/285	1.4	2.5/45	1.4 + L/256	1.4	2.5/45
HH-A, HH-AS/TP200	1.9 + L/333	1.9	–	1.9 + L/285	1.9	–	1.9 + L/256	1.9	–
HH-A, HH-AS/HP-T, HP-TM	2.1 + L/333	2.0	–	2.1 + L/285	2.0	–	2.1 + L/256	2.0	–
DEA GLOBAL Silver SF 12.xx.10									
HP-S-X3C/X5	2.1 + L/333	1.8	3.1/45	2.1 + L/277	1.8	3.1/45	2.1 + L/250	1.8	3.1/45
HH-A, HH-AS/HP-S-X1S, H	2.1 + L/333	1.8	3.1/45	2.1 + L/277	1.8	3.1/45	2.1 + L/250	1.8	3.1/45
HH-A, HH-AS/TP200	2.5 + L/333	2.2	–	2.5 + L/277	2.2	–	2.5 + L/250	2.2	–
HH-A, HH-AS/HP-T, HP-TM	2.7 + L/333	2.6	–	2.7 + L/277	2.6	–	2.7 + L/250	2.6	–

Probe Configuration	$R_{0,MPL}^{(1)}$	$R_{0,MPL}^{(2)}$
HP-S-X3C/X5	1.2	1.7
HH-A, HH-AS/HP-S-X1S, H	1.2	1.7
HH-A, HH-AS/TP200	2.1	2.7
HH-A, HH-AS/HP-T, HP-TM	2.1	2.7

NOTE: $E_{0,MPE}/E_{150,MPE}$ specifications are to be formally understood as $E_{0,MPE}^*/E_{150,MPE}^*$ for the case where non-normal CTE material calibrated test lengths are used.

(1) $R_{0,MPL}$ referred to DEA GLOBAL 09.xx.08

(2) $R_{0,MPL}$ referred to DEA GLOBAL 12.xx.10

Probe Configuration for performance test:

- HP-S-X3C/X5: stylus length 60 mm, tip diameter 5 mm
- HP-S-X1S: without extension, stylus length 50 mm, tip diameter 5 mm
- HP-S-X1H: with an extension of 100 mm, stylus length 20 mm, tip diameter 5 mm
- TP200: Standard Force Module, stylus length 10 mm, tip diameter 4 mm
- HP-T: Standard Force, stylus length 10 mm, tip diameter 4 mm
- HP-TM: Standard Force Module, stylus length 10 mm, tip diameter 4 mm

Dynamics:

- Max. 3D Speed: 866 mm/s
- Max. 3D Accel.: 4300 mm/s² (1400 mm/s² with HP-S-X3C/X5)
- Max. Scanning Speed : 500 mm/s

Performance data are valid if the following specification are met:

Temperature Range 18 ÷ 22 °C
 Max. air temperature variation 1 °C/h - 2 °C/24h
 Max. air temperature variation 1 °C/m

Temperature Range 16 ÷ 26 °C
 Max. air temperature variation 1 °C/h - 5 °C/24h
 Max. air temperature variation 1 °C/m

Temperature Range 15 ÷ 30 °C (*)
 Max. air temperature variation 1 °C/h - 5 °C/24h
 Max. air temperature variation 1 °C/m

(*) Accuracy values under the conditions below are available on request:

Temperature Range 15 ÷ 30 °C
 Max. air temperature variation 2 °C/h - 10 °C/24h
 Max. air temperature variation 1 °C/m

Strokes, Dimensions and Weights

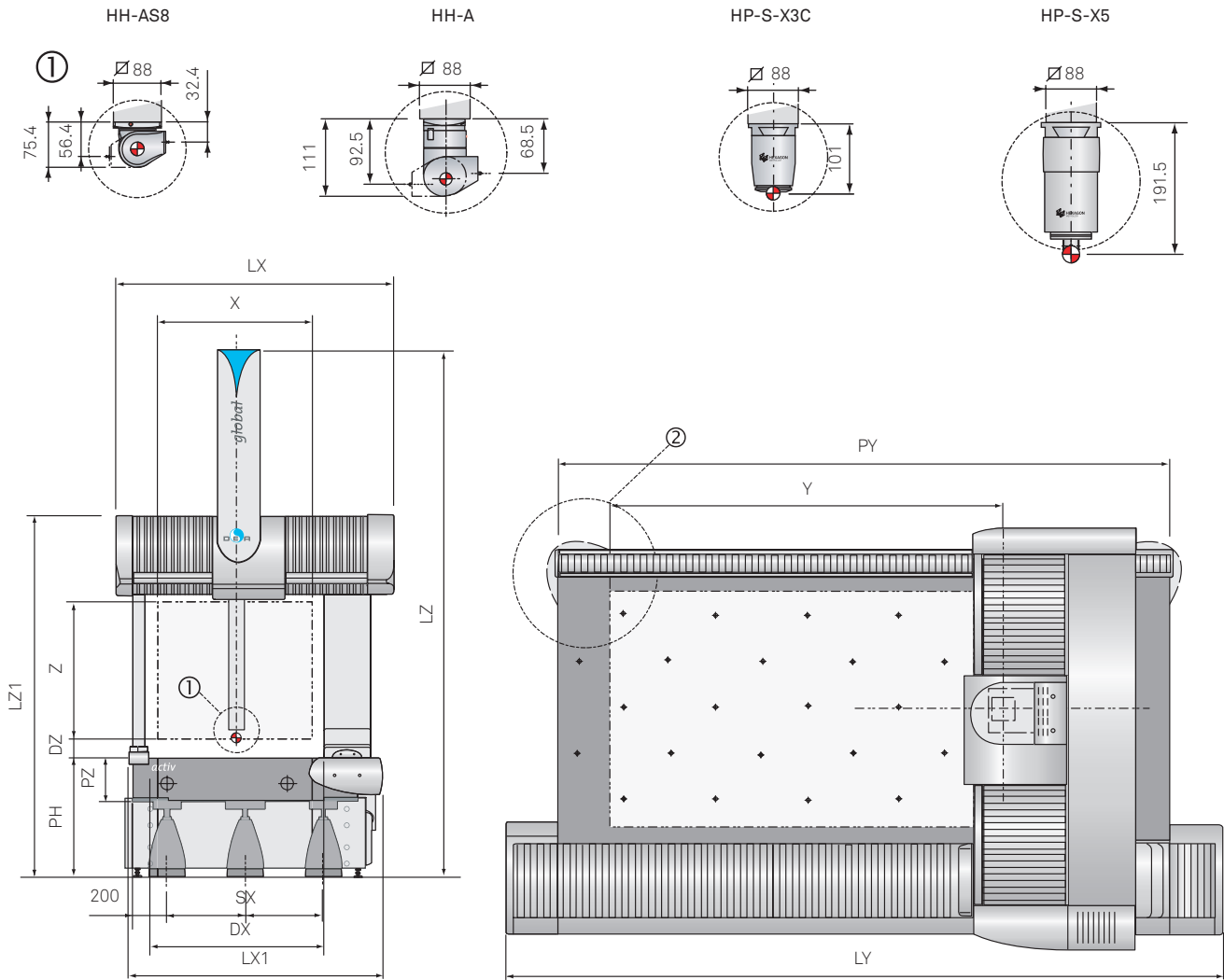

12.15.10
12.22.10

12.30.10

09.15.08

09.12.08
09.20.08

(a) With HP-S-X5 probe head, Z stroke = 665 mm

(b) With HP-S-X5 probe head, Z stroke = 905 mm

Models	Strokes (mm)			Overall Dimensions (mm)					Surface Plate (mm)		Day lights (mm)		Thd Insert (mm)	Max. Part Weigh (kg)	CMM Weight (kg)		
	X	Y	Z	LX	LX1	LY	LZ	LZ1	SX	PZ	PH	PY	DX			DZ	D1
09.12.08	900	1200	800 ^(a)	1610	1478	2430	3066	2104	910	250	700	2030	1018	117	76	1300	2286
09.15.08	900	1500	800 ^(a)	1610	1478	2730	3066	2104	910	250	700	2330	1018	117	51	1500	2567
09.20.08	900	2000	800 ^(a)	1610	1478	3230	3051	2104	910	275	725	2830	1018	117	126	1800	3316
12.15.10	1200	1500	1000 ^(b)	1908	1777	2880	3431	2244	1210	290	625	2480	1318	150	149	1800	3792
12.22.10	1200	2200	1000 ^(b)	1908	1777	3580	3406	2244	1210	350	600	3180	1318	150	149	2250	5679
12.30.10	1200	3000	1000 ^(b)	1908	1777	4380	3431	2244	1210	380	625	3980	1318	150	24	2250	7587



Technical Characteristics	HH-AS8 Probe Head	HH-A Indexable Probe Head
Angular rotation		A axis: +90° / -115° B axis: ±180°
Angular rotation step		5°
Rotation speed		90° in 2 seconds
Positioning repeatability		0.5 µm
Max. applied torque		0.6 Nm
Extensions		Max. length 300 mm



Technical Characteristics	HP-S-X1C	HP-S-X3C	HP-S-X5
Resolution	<1 µm	<1 µm	<1 µm
Measuring range	± 2 mm in X, Y and Z	± 1 mm in X, Y and Z	1 mm in X, Y and Z
Overtravel range	± 2 mm in all axes	± 1.25 mm in all axes	± 1 mm in all axes
Linear stiffness	1.2 N/mm	5 N/mm	5 N/mm
Stylus joint	M3	M5	M5
Max. stylus weight	33 g	150 g	500 g
Max. stylus length	Vertical: 20 - 115 mm Horizontal: up to 50 mm	360 mm	500 mm

HP-L-10.6T Laser Sensor



Technical Characteristics	
Laser	Visible red, class 2, 690 nm
Standoff and depth of FOV	170 ± 30 mm
Width of FOV user selectable	24, 60, 124 mm
Line per second (max)	53 Hz
Temperature range of sensor for declared accuracy	15 ~ 32 °C
Sensor size L x W x H	134 x 72 x 60,5 mm
Sensor weight	382 g
Probing error (*)	MPE _{PF(OT)} 60 µm

NOTE: Available on DEA GLOBAL Silver SF 09.xx.08 - 12.xx.10

(*) According to VDI 2617 Part 6.2, October 2005 edition

$E_{0,MPE}$: maximum permissible error of length measurement

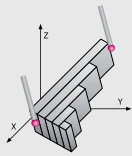

5 gauges have to be measured 3 times with one probing at each end, in 7 different directions. All measuring results must be within E_0 .

$E_{150,MPE}$: maximum permissible error of length

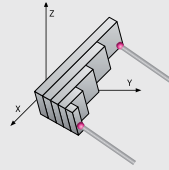

5 length gauges have to be measured 3 times in the YZ- or XZ plane with opposite styli, mounted 150 mm off the Z spindle axis.

$R_{0,MPL}$: maximum permissible limit of the repeatability range

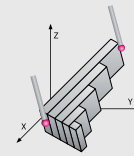

Extreme value of the repeatability range of the length measurement error, calculated by three repeated measurements on each size for a total of 35 values. The 35 repeatability range results must be within the specified $R_{0,MPL}$.

$P_{FTU,MPE}$: maximum permissible single stylus form error

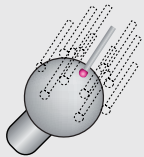

A precision sphere has to be measured with 25 problings. P_{FTU} is the range of all radii.
 $P_{FTU} = R_{max} - R_{min} =$ sphere form.
 Calibration sphere in the middle of the volume.

$MPE_{THP/L}$: maximum permissible scanning probing error

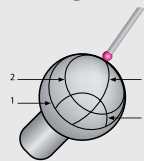

A precision sphere has to be scanned with 4 defined lines. THP is the range of all radii.
 $THP = R_{max} - R_{min} =$ sphere form, scanning.
 Calibration sphere in the middle of the volume.

Technical Characteristics

Mechanical Frame: X: Micromachined anodized light alloy extrusion
 Y: Integral dovetail guideways, machined into the table
 Z: Micromachined anodized light alloy extrusion

Surface Plate: Material: Granite
 Part Locking: threaded inserts M8 x 1.25
 Flatness: according to DIN 876/III

Sliding System: Air bearings on all axes

Measuring System: METALLUR® linear scales. System Resolution: 0.039 µm

Temperature Compensation: Structural multi-sensor temperature compensation

Ram Counterbalance: Pneumatic, adjustable

Bellows and Covers: X and Y air bearing guideways with bellows

Air Supply: Minimum air supply pressure: 0.5 MPa
 Air consumption: 150 NL/min

Environment: Metrological specification temperature range: 18 ÷ 22 °C; 16 ÷ 26 °C; 15 ÷ 30 °C
 Operating temperature: 10 ÷ 40 °C
 Relative humidity: 20% - 90% non condensing

Probe Heads and Sensors: HH-A, HH-AS8, HP-S-X1C, HP-S-X3C, HP-S-X5
 TP200, HP-T, HP-TM, HP-S-X1, HP-L-10.6T

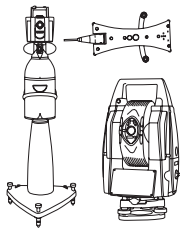

LASER TRACKERS & STATIONS



PORTABLE MEASURING ARMS

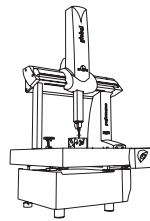

BRIDGE CMMs

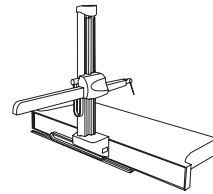

HORIZONTAL ARM CMMs

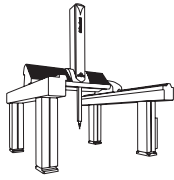

GANTRY CMMs

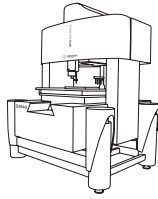

MULTISENSOR & OPTICAL SYSTEMS

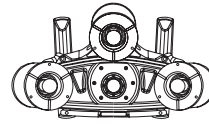

WHITE LIGHT SCANNERS

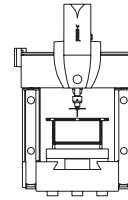

ULTRA HIGH ACCURACY CMMs



SENSORS

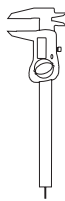

PRECISION MEASURING INSTRUMENTS



SOFTWARE SOLUTIONS



HEXAGON
METROLOGY

Hexagon Metrology offers a comprehensive range of products and services for all industrial metrology applications in sectors such as automotive, aerospace, energy and medical. We support our customers with actionable measurement information along the complete life cycle of a product – from development and design to production, assembly and final inspection.

With more than 20 production facilities and 70 Precision Centers for service and demonstrations, and a network of over 100 distribution partners on five continents, we empower our customers to fully control their manufacturing processes, enhancing the quality of products and increasing efficiency in manufacturing plants around the world.

For more information, visit www.hexagonmetrology.com

Hexagon Metrology is part of Hexagon (Nordic exchange: HEXA B). Hexagon is a leading global provider of design, measurement and visualisation technologies that enable customers to design, measure and position objects, and process and present data.

Learn more at www.hexagon.com

© 2014 Hexagon Metrology. Part of Hexagon

All rights reserved. Due to continuing product development, Hexagon Metrology reserves the right to change product specifications without prior notice.

Printed in Germany. July 2014