

INTEGRATED DOVETAIL CHANNELS  
ALLOW MULTIPLE XR25 SERIES STAGES  
TO BE STACKED INTO AN X/Y CONFIGURATION

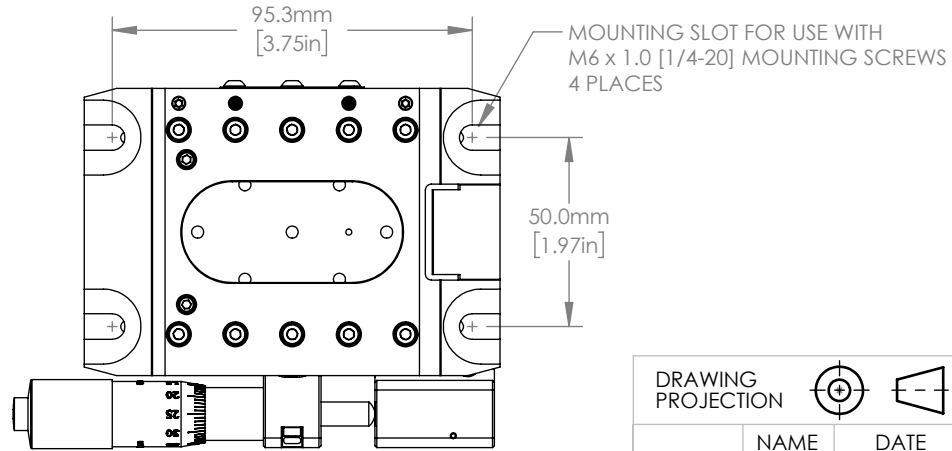
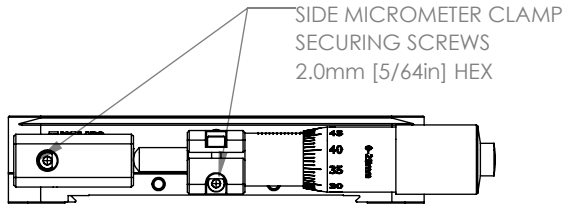
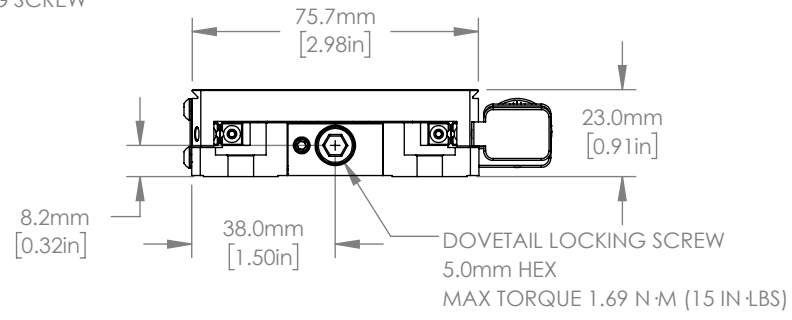
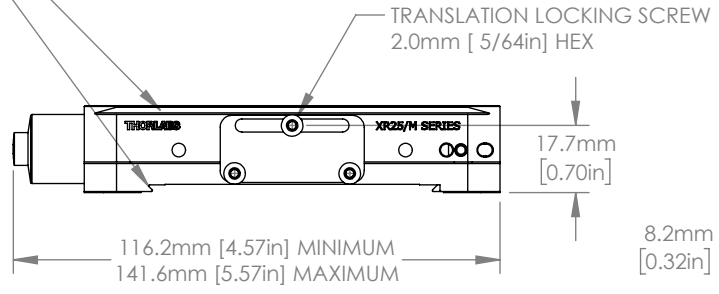
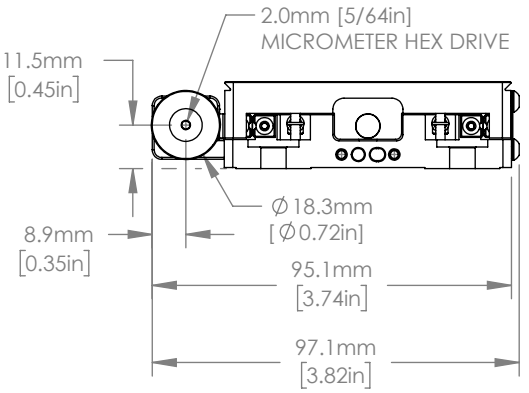

FOR INFORMATION ONLY  
NOT FOR MANUFACTURING PURPOSES

DRAWING PROJECTION			<b>THORLABS</b> www.thorlabs.com	
NAME	DATE	METRIC 25mm CROSSED ROLLER SIDE ACUATED TRANSLATION STAGE		
DRAWN	BJ	05/27/16	MATERIAL	
APPROVAL	CS	05/31/16	REV D	
COPYRIGHT © 2016 BY THORLABS			N/A	
VALUES IN PARENTHESIS ARE CALCULATED AND MAY CONTAIN ROUND OFF ERRORS		ITEM #	APPROX WEIGHT	
		XR25P/M	0.51kg	