

(2) Ø 3/32in X 3/16in DOWEL PINS INCLUDED WITH PURCHASE

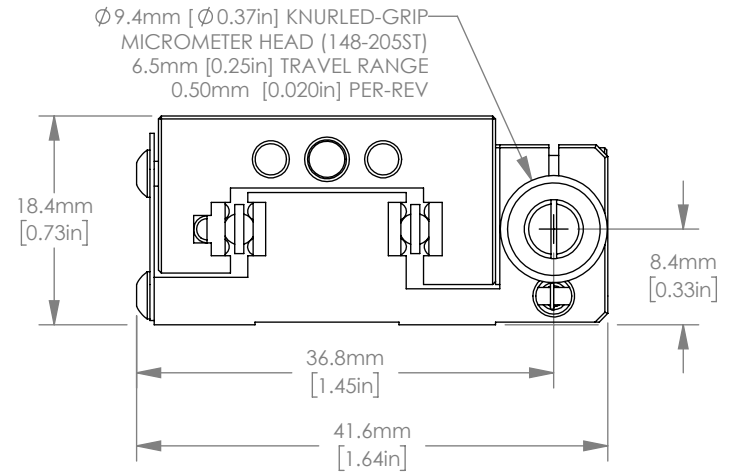
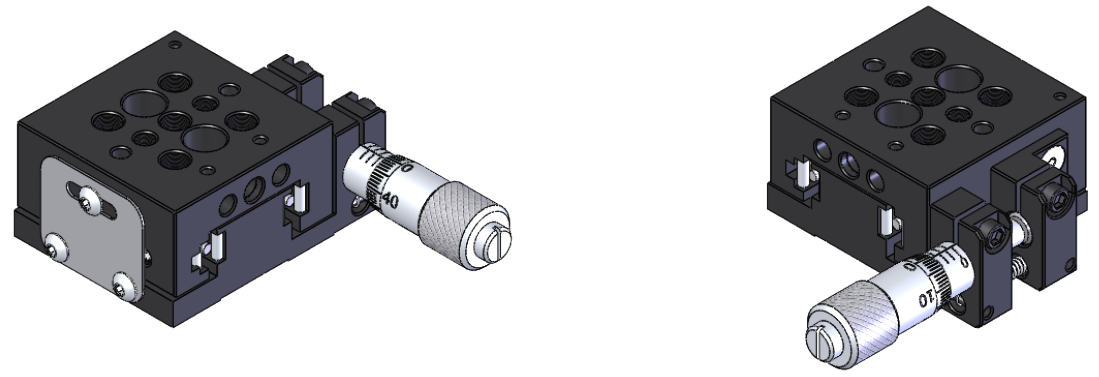

FOR INFORMATION ONLY
NOT FOR MANUFACTURING PURPOSES

DRAWING PROJECTION			THORLABS www.thorlabs.com	
NAME	DATE	6.5mm TRAVEL, SIDE-ACTUATED TRANSLATION STAGE		
DRAWN	CS	24/MAY/12	REV E	
APPROVAL	TLB	25/MAY/12	MATERIAL	N/A
COPYRIGHT © 2012 BY THORLABS			ITEM #	APPROX WEIGHT
VALUES IN PARENTHESIS ARE CALCULATED AND MAY CONTAIN ROUND OFF ERRORS			MS1S/M	0.03 kg