

PZ 129E User Manual

E-651 / E-614 Controller / Amplifier for Bender Actuators

Release: 6.0.0

Date: 2004-07-14



This document describes the following Product(s):

- **E-651.1S**
Piezo Controller/Amplifier for Bender Actuators with SGS, single channel
- **E-651.2S**
Piezo Controller/ Amplifier for Bender Actuators with SGS, dual channel
- **E-614.2BS**
Piezo Controller/ Amplifier for Bender Actuators with SGS, OEM version, dual channel



© **Physik Instrumente (PI) GmbH & Co. KG**
 Auf der Römerstr. 1 · 76228 Karlsruhe, Germany
 Tel. +49-721-4846-0 · Fax: +49-721-4846-299
 info@pi.ws · www.pi.ws

Declaration of Conformity

The manufacturer,

Physik Instrumente (PI) GmbH & Co. KG

Auf der Roemerstrasse 1

76228 Karlsruhe, Germany

declares, that the product E-651 / E-614 Controller/amplifier for Bender Actuators complies with these EMC specifications regarding

EN-500081-1(3/93), (Generic Standard):

EN-55022 (1991), Class B

EN-55014

CISPR 22, Class B

with these EMC specifications regarding

EN-500082-1(3/93), (Generic Standard):

IEC 801-2(1991), 4kV contact discharge, 8 kV air discharge

IEC 801-3(1994), 3 V/m

IEC 801-4(1988), 1 kV line cord, 0.5 kV data lines

The product complies with the requirements of the EMC Directive 89/336/EEC and the CE markings have been affixed on the devices.



Physik Instrumente (PI) GmbH & Co. KG is the owner of the following company names and trademarks: PICMA®

Copyright 1999–2004 by Physik Instrumente (PI) GmbH & Co. KG, Karlsruhe, Germany. The texts, photographs and drawings in this manual enjoy copyright protection. With regard thereto, Physik Instrumente (PI) GmbH & Co. KG reserves all rights. Use of said texts, photographs and drawings is permitted only in parts and only upon citation of the source.

First printing 2004-07-14

Document Number PZ 129E, Release 6.0.0

E-614_User_PZ129E600.doc

This manual has been provided for information only and product specifications are subject to change without notice. Any change will be reflected in future printings.

About this Document

Users of this Manual

This manual is designed to help the reader to install and operate the E-651 / E-614 Controller/amplifier for Bender Actuators. It assumes that the reader has a fundamental understanding of basic servo systems, as well as motion control concepts and applicable safety procedures.

The manual describes the physical specifications and dimensions of the E-651 / E-614 Controller/amplifier for Bender Actuators as well as the hardware installation procedures which are required to put the motion system into operation.

Updated releases of this document are available via FTP or email: contact your Physik Instrumente sales engineer or write info@pi.ws

Conventions

The notes and symbols used in this manual have the following meanings:



WARNING

Calls attention to a procedure, practice or condition which, if not correctly performed or adhered to, could result in injury or death.



WARNING-HIGH VOLTAGE

Indicates the presence of high voltage (> 50 V). Calls attention to a procedure, practice or condition which, if not correctly performed or adhered to, could result in injury or death.



CAUTION

Calls attention to a procedure, practice, or condition which, if not correctly performed or adhered to, could result in damage to equipment.

Related Documents

E-801 sensor-processing submodules and E-802 servo-control submodules, which are installed on the E-651 / E-614 main board at factory, are described in their own manuals. All documents are available as PDF files via FTP or email: contact your Physik Instrumente sales engineer or write info@pi.ws:

E-801_User_PZ117E
E-802UserPZ113E

Contents

1	Introduction	3
1.1	Overview	3
1.2	Safety Precautions	4
1.3	Model Survey	6
1.4	Unpacking	6
1.5	System Requirements	7
2	Starting Operation	9
2.1	E-651 Bench-Top Unit.....	9
2.1.1	Element Description.....	9
2.1.2	Getting Started.....	11
2.2	E-614 OEM PCB	13
2.2.1	Element Description.....	14
2.2.2	Getting Started.....	16
3	Principles of Operation	18
3.1	Full Differential-Voltage Control	18
3.2	Operating Modes.....	18
3.2.1	Closed-Loop Operation.....	18
3.2.2	Open-Loop Operation	19
3.3	On-Board Submodules.....	19
3.3.1	E-801 Submodule for Strain Gauge Sensor Processing.....	19
3.3.2	E-802 Position Servo-Control Submodule	20
4	Calibration	21
4.1	Equipment Needed	22
4.2	Zero-Point Adjustment	22
5	Troubleshooting	24
5.1	Typical Problems.....	24
5.2	Opening the E-651 Case.....	25
6	Technical Data	26
6.1	Specifications	26

Contents

6.2	Pin Assigment	27
6.2.1	E-651 PZT & SENSOR connector	27
6.2.2	E-614 Sensor Input Connectors.....	27

1 Introduction

1.1 Overview

E-651 is a bench-top piezo controller, especially designed for low-voltage, multilayer piezo bender actuators such as the P-871, which require full differential-voltage control and are equipped with strain gauge sensors.

One- and two-channel versions of the E-651 are available. The E-614.2BS OEM board provides the same functionality as the E-651.2S 2-channel controller, but on a printed circuit board.

A wide-range power supply is included with the E-651.



Fig. 1: E-651-series controller/amplifier (E-651.2S at left, E-651.1S at right)



Fig. 2: E-614 OEM controller/amplifier

The above devices each comprise a power amplifier, DC sensor excitation and readout circuitry with preamplifier and different filters, together with a proportional-integral (P-I) controller for closed-loop operation.

Channels can be operated in either open-loop mode, where the output voltage is controlled by an analog input signal, or closed-loop mode, where the displacement (position) of the bender is controlled by the analog input signal.

E-651 / E-614 features at a glance:

- Controller for Closed-Loop Multilayer "Bimorph" Actuators
- 1- and 2-Channel Versions
- Bench-Top and OEM-Board Versions

1.2 Safety Precautions

WARNING

Failure to heed warnings in this manual can result in bodily injury or material damage. Note that E-651 / E-614 Controller/Amplifier do not contain any user-serviceable parts.



CAUTION

The E-614.2BS Controller/Amplifier PCB and its submodule boards (E-801, E-802) are ESD-sensitive (electrostatic discharge sensitive) devices. Observe all precautions against static charge buildup before handling these devices.

Avoid touching circuit components, pins and PCB traces. Discharge any static charge you may have on your body by briefly touching a conductive, grounded object before you touch any electronic assembly. Pose PCBs only on conductive surfaces, such as ESD-safe transport containers (envelopes, foam). Electronic subassemblies must always be kept and transported/shipped in conductive packaging.

Make sure that no conductive particles of any kind (metallic dust or shavings, broken pencil leads, loose screws) contact the device circuitry.



WARNING—HIGH VOLTAGE

E-651s and E-614s are amplifiers generating high voltages of up to 60 V for driving piezo actuators. The output power may cause serious injuries.



Working with these devices or using piezoelectric products from other manufacturers we strictly advise you to follow the General Accident Prevention Regulations.

All work done with and on the devices described here requires adequate knowledge of handling high voltages.

CAUTION

Do not apply any input voltage to the SENSOR MONITOR socket. This could cause damage to the electronics.



CAUTION

Handle bender actuators (ceramic elements!) with care! Do not drop a bender actuator; avoid subjecting it to any kind of mechanical shock.



CAUTION

If you hear or see any resonant behavior, switch off power to the actuator immediately. See the PI catalog or the product documentation for the bender actuators for the unloaded resonant frequency..



CAUTION

Calibration of the controller is done prior to delivery by the manufacturer.

Do not adjust potentiometers unnecessarily. Any calibration procedures are to be carried out by qualified authorized personnel only.





CAUTION

Do not interchange controller and / or actuators since they are matched and calibrated together. Respect the designation of the actuators to the individual controller channels, which is readily identifiable with the serial numbers of the devices.

1.3 Model Survey

The following models are available:

Model	Description	Notes
E-651.1S	Piezo controller/amplifier for bender actuators with SGS, single channel (for one bender actuator)	bench-top unit, see Fig. 1
E-651.2S	Piezo controller/amplifier for bender actuators with SGS, dual channel (for up to two bender actuators)	bench-top unit, see Fig. 1
E-614.2BS	Piezo controller/amplifier for bender actuators with SGS, OEM PCB, dual channel (for up to two bender actuators)	PCB for OEM applications, see Fig. 2, functionality corresponds to E-651.2S

1.4 Unpacking



CAUTION

The E-614.2BS Controller/Amplifier PCB and its submodule boards (E-801, E-802) are ESD-sensitive (electrostatic discharge sensitive) devices. Observe all precautions against static charge buildup before handling these devices.

Avoid touching circuit components, pins and PCB traces. Discharge any static charge you may have on your body by briefly touching a conductive, grounded

object before you touch any electronic assembly. Pose PCBs only on conductive surfaces, such as ESD-safe transport containers (envelopes, foam). Electronic subassemblies must always be kept and transported/shipped in conductive packaging.

Make sure that no conductive particles of any kind (metallic dust or shavings, broken pencil leads, loose screws) contact the device circuitry.

Unpack the E-651 / E-614 controller/amplifier with care. Compare the contents against the sales contract and packing slip.

The following components should be included with the E-651:

- E-651 controller/amplifier bench-top device
- C-890.PS power supply with line cord
- User Manual for E-651 / E -614 (this document) in printed form

The following components should be included with E-614s:

- E-614 controller/amplifier OEM PCB (with two E-801 and two E-802 submodules installed)
- User Manual for E-651 / E -614 (this document) in printed form

Inspect the contents for signs of damage. If parts are missing or you notice damage, such as loose contacts or hairline cracks, please contact PI immediately.

Save all packing materials in the event the product need be shipped elsewhere.

Contact your PI sales engineer or write info@pi.ws if you need additional components.

1.5 System Requirements

To start working with the E-651 / E- 614 controller/amplifier, you need the following:

- Supply voltage in the range of 14 to 16 VDC (C-890.PS power supply comes with E-651)

- For each channel used, an input control voltage in the range of -5 V to +5 V on a suitable connector (BNC for E-651, Molex for E-614)
- For each channel used, a multilayer piezo bender actuator with integrated strain gauge sensor (SGS), e.g. P-871, each with suitable connector (7-conductor LEMO for E-651, or Molex for E-614)

2 Starting Operation

Note that upon delivery the system is ready for operation: all of PI's piezo positioning systems are delivered with performance test documents to verify the system performance, and calibration of the controller is done prior to delivery in our lab. Actuators and assigned controller channels are matched and should be kept together as a unit. The serial number of the assigned actuator is marked on the associated controller channel.

Normally, you do not need to calibrate the system. Only if the actuator, mechanical setup, cables to the bender actuator are replaced, or if a large change in operating temperature occurs, is recalibration necessary. Should you ever need to make a new full calibration, read section 4 on page 21.

2.1 E-651 Bench-Top Unit

2.1.1 Element Description



Fig. 3: E-651 front panel; elements for channel 2 are not present on single-channel models

Common elements:

ON (Power) LED Power on/off indicator

Elements provided once per channel:

OFL LED Lights up if the output voltage is outside the nominal output voltage range of the controller

SERVO ON/OFF	Switch for changing between open-loop (off) and closed-loop mode (on)
CONTROL IN	BNC connector for the analog control signal, -5 V to +5 V



CAUTION

Do not apply any input voltage to the SENSOR MONITOR socket. This could cause damage to the electronics.

SENSOR MONITOR	BNC connector for reading out the sensor input signal (0 to 10 V)
ZERO	This potentiometer shifts the output of the sensor processing circuitry
PZT & SENSOR	7-conductor LEMO connector with PZT outputs (constant +60 V and power-amp output 0 to +60 V), as well as sensor excitation (5 V DC) and input signal



Fig. 4: E-651 rear panel details

POWER	ON/OFF switch
14 to 16V DC INPUT	Operating power input, socket for the barrel connector from the C-890.PS power supply (included)

2.1.2 Getting Started

WARNING—HIGH VOLTAGE



E-651s and E-614s are amplifiers generating high voltages of up to 60 V for driving piezo actuators. The output power may cause serious injuries.

Working with these devices or using piezoelectric products from other manufacturers we strictly advise you to follow the General Accident Prevention Regulations.

All work done with and on the devices described here requires adequate knowledge of handling high voltages.

CAUTION



Do not apply any input voltage to the SENSOR MONITOR socket. This could cause damage to the electronics.

CAUTION



Handle bender actuators (ceramic elements!) with care! Do not drop a bender actuator; avoid subjecting it to any kind of mechanical shock.

CAUTION



If you hear or see any resonant behavior, switch off power to the actuator immediately. See the PI catalog or the product documentation for the bender actuators for the unloaded resonant frequency..

CAUTION



Do not interchange controller and/or actuators; they are matched and calibrated together. Respect the

assignment of the actuators to the individual controller channels, as indicated by the serial numbers on the labels affixed to the devices.

Carry out the following steps to put the motion system into operation:

1. Connect the actuators to the proper controller channel(s) using the PZT & SENSOR socket(s). Handle the actuators with care and avoid any kind of mechanical shock.
2. Optionally: If you want to read out the sensor signal for a channel, connect a voltmeter (not included) to the appropriate SENSOR MONITOR socket.
3. With the POWER switch on the rear panel set to OFF, connect the controller to the C-890.PS power supply (included) using the 14 to 16 VDC INPUT socket, and connect the power supply to the line power (100–240 VAC, 50/60 Hz).
4. Select the operating mode for each channel using the corresponding SERVO ON/OFF switch on the controller.
If SERVO is ON (closed-loop mode), the control input voltage is used as the target position value for the servo-control circuit, and determines the position of the bender. If SERVO is OFF (open-loop mode), the output voltage for the bender actuator is in direct linear relation to the control input voltage.
5. Connect a control-input voltage source (-5 V to +5 V DC) to the CONTROL INPUT socket for each controller channel.
6. Power up the E-651 controller using the POWER switch on the rear panel. The POWER LED on the front panel lights up.
7. Deflect the actuator(s): apply a control input voltage in the range from -5 V to +5 V to the channel(s).
You can monitor the actuator deflection with the SENSOR MONITOR signal (see step 2; 0 V to 10 V), even when the system is in open-loop mode.
If the output voltage corresponding to the control

input signal is outside the output voltage range (0 to 60 V), the OFL (overflow) LED for the channel lights and remains on as long as the overflow condition persists.

2.2 E-614 OEM PCB

CAUTION



The E-614.2BS Controller/Amplifier PCB and its submodule boards (E-801, E-802) are ESD-sensitive (electrostatic discharge sensitive) devices. Observe all precautions against static charge buildup before handling these devices.

Avoid touching circuit components, pins and PCB traces. Discharge any static charge you may have on your body by briefly touching a conductive, grounded object before you touch any electronic assembly. Pose PCBs only on conductive surfaces, such as ESD-safe transport containers (envelopes, foam). Electronic subassemblies must always be kept and transported/shipped in conductive packaging.

Make sure that no conductive particles of any kind (metallic dust or shavings, broken pencil leads, loose screws) contact the device circuitry.

2.2.1 Element Description

Mating connectors with color-coded, open-end conductors are provided. See Fig. 6 and p. 15 for pinouts.

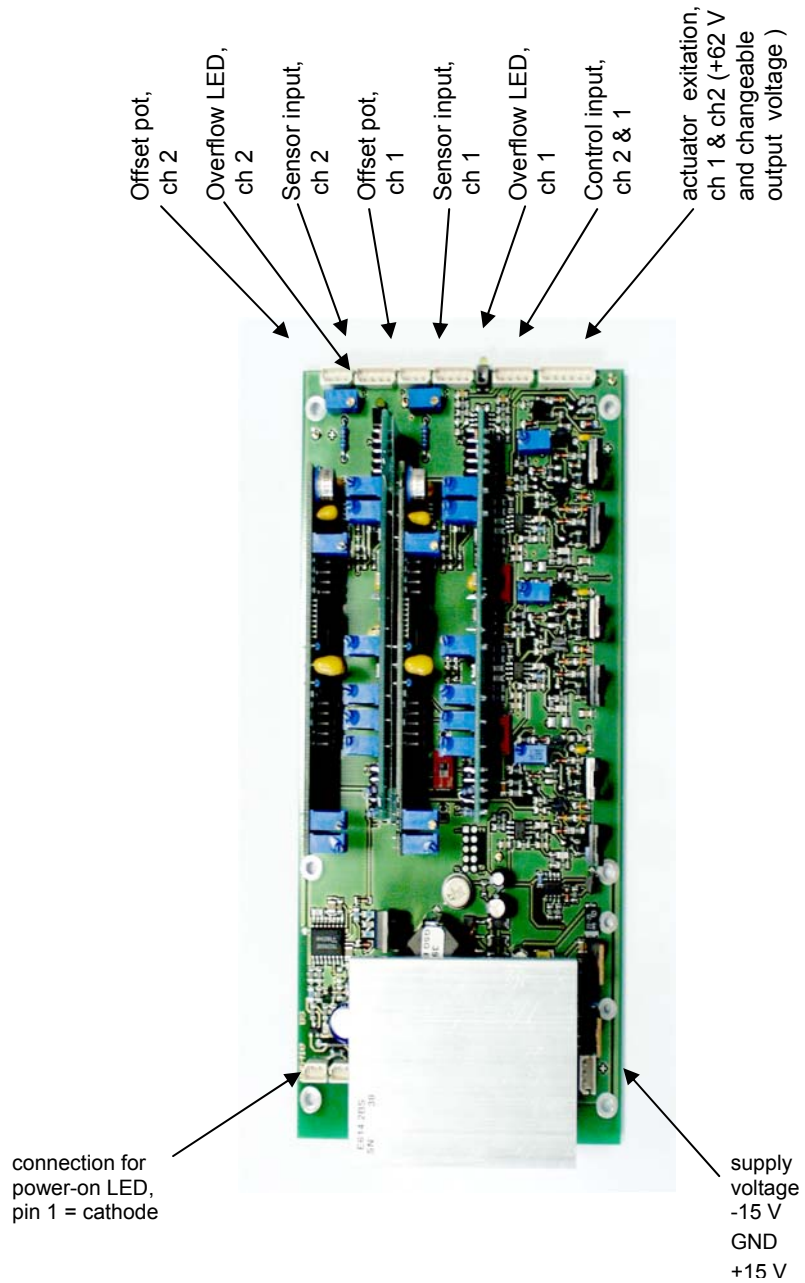
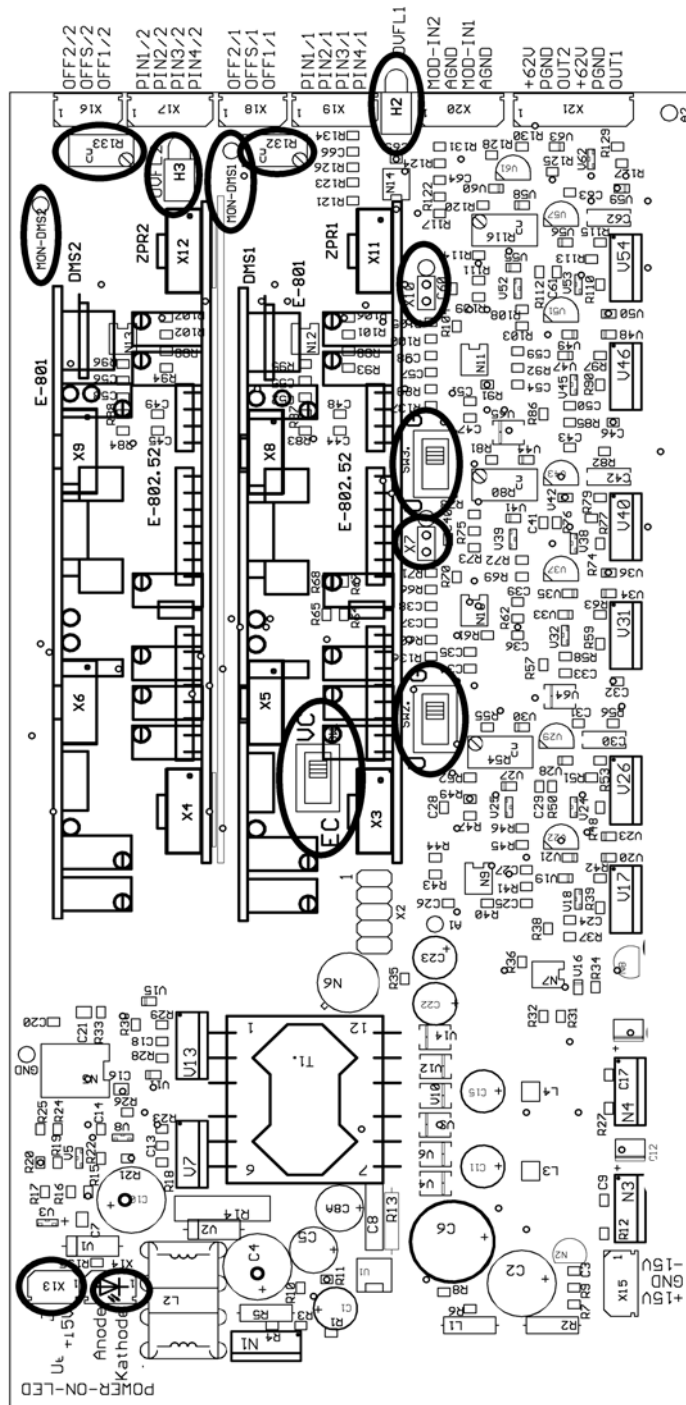

Fig. 5. Connections overview



EC/VC switch: EC enables servo-control (closed-loop mode). EC-setting is superseded, if SW2 and SW3 are set to U (open-loop)!

SW2: U-G switch, U to bypass E-802 servo-control submodule for channel 2 completely (open-loop "amplifier-only" operation); G to enable

SW3: U-G switch, U to bypass E-802 servo-control submodule for channel 1 completely (open-loop "amplifier-only" operation); G to enable

X7: Short to activate offset pot for channel 2 (connected to X16)

X10: Short to activate offset pot for channel 1 (connected to X18)

MON-DMS1, MON-DMS2: Strain gauge sensor monitor test point

R-132: Zero potentiometer for channel 1

R-133: Zero potentiometer for channel 2

X13: Supply, pin 1 +14 to +16V, pin 2 GND

X14: connection for off-board power-on LED

H2: Overflow LED for channel 1

H3: Overflow LED for channel 2

For more pinouts see p. 27

Component layout on E-801 and E-802 submodules depends on submodule model installed. See submodule User Manuals for details.

Fig. 6. Component and connection locations in detail; important adjustment and test elements circled

2.2.2 Getting Started



WARNING—HIGH VOLTAGE

E-651s and E-614s are amplifiers generating high voltages of up to 60 V for driving piezo actuators. The output power may cause serious injuries.

Working with these devices or using piezoelectric products from other manufacturers we strictly advise you to follow the General Accident Prevention Regulations.

All work done with and on the devices described here requires adequate knowledge of handling high voltages.



CAUTION

Handle bender actuators (ceramic elements!) with care! Do not drop a bender actuator; avoid subjecting it to any kind of mechanical shock.



CAUTION

If you hear or see any resonant behavior, switch off power to the actuator immediately. See the PI catalog or the product documentation for the bender actuators for the unloaded resonant frequency.



CAUTION

Do not interchange controller and / or actuators since they are matched and calibrated together. Respect the designation of the actuators to the individual controller channels, which is readily identifiable with the serial numbers of the devices.

Carry out the following steps to put the motion system into operation (for component location and pinouts see Fig. 6):

1. Connect the piezo actuators to the controller board using the X21 socket. Handle the actuators with care and avoid any kind of mechanical shock.
2. Optionally: If you want to use the sensor signal for a channel, connect your electronics to the corresponding MON-DMS test point (Fig. 6).
3. Select the operating mode (open-loop or closed loop) for each channel using the SW2 and SW3 switches and the EC/VC switch. For details see p. 18.
4. Connect the control-input voltages (-5 V to +5 V DC) for the controller channels to the X20 socket.
5. Connect the supply power (14 to 16 VDC) to the X15 supply power connector. If you have connected an (optional) POWER LED to the X14 socket, it will light up.
6. Deflect the actuator(s): apply a control input voltage in the range from -5 V to +5 V to the channel(s).
You can monitor the actuator deflection with the SENSOR MONITOR signal (see step 2; 0 V to 10 V), even when the system is operated in open-loop mode.
If the output voltage corresponding to the control input signal is outside the output voltage range (0 to 60 V), the OFL (overflow) LED for the channel lights and remains on as long as the overflow condition persists.

3 Principles of Operation

3.1 Full Differential-Voltage Control

E-651/E-614 controller/amplifiers are specially designed to operate PICMA™ multilayer bender actuators from PI (see PI catalog). These actuators require full differential-voltage control with constant voltages of 0 V and +60 V and a variable voltage from 0 V to +60 V (see Fig. 7). Note that a control input voltage of 0 V corresponds to a PZT variable output of about +30 V, which puts the actuator in the middle position (i.e. deflection $\approx 0 \mu\text{m}$).

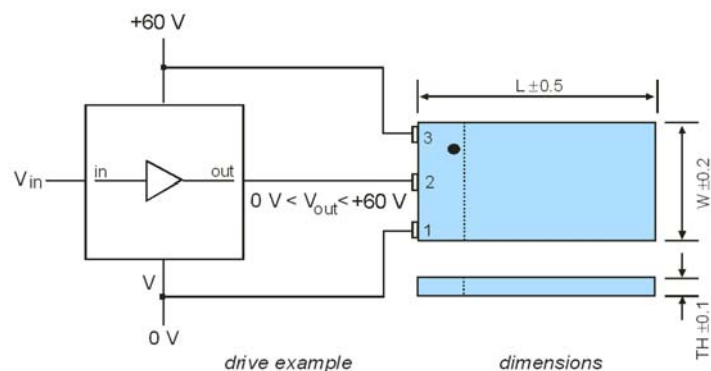

Fig. 7. PICMA™ multilayer bender actuator with full differential-voltage control,

Pin assignment:	1	-0 V [or GND]
	2	-0 V to +60 V
	3	+60 V

3.2 Operating Modes

E-651 / E-614 controller/amplifiers can be operated in closed-loop or open-loop mode.

The position signal is available in either operating mode in the form of a sensor monitor signal from 0 to 10 V. Note that +5 V corresponds to mid-position of the actuator.

3.2.1 Closed-Loop Operation

In closed-loop mode, it is the **deflection** (position) of the bender that is controlled by the control input signal, which is processed by the E-802 servo-control submodule (see section 3.3.2).

An E-651 channel is in closed-loop mode if the corresponding SERVO switch on the front panel is set to ON.

An E-614 channel operates in closed-loop mode, if

- EC/VC switch is set to EC

and

- Switch SW3 (channel 1) and SW2 (channel 2) are set to G (if one of these switches is set to U, the corresponding channel is in open-loop mode, even if the EC/VC switch is set to EC)

For component location see Fig. 6 on p. 15.

3.2.2 Open-Loop Operation

In open-loop mode the variable output voltage for the actuator is controlled by the control input signal (this output voltage for the bender actuator is in direct linear relation to the control input voltage).

An E-651 channel is in open-loop mode, if the corresponding SERVO switch on the front panel is set to OFF.

An E-614 channel is in open-loop mode, if

- EC/VC switch is set to VC (both channels)

or

- Switch SW3 (channel 1) or SW2 (channel 2) is set to U

For component location see Fig. 6 on p. 15.

3.3 On-Board Submodules

Each E-651 / E-614 channel is equipped with submodules for sensor processing (E-801) and servo-control (E-802). If you ever have to remove and replace any of the submodules, be sure to preserve the orientation of the component sides as shown in Fig. 6 on p. 15.

3.3.1 E-801 Submodule for Strain Gauge Sensor Processing

This submodule is used for excitation and evaluation of one strain gauge sensor (SGS). It is designed as a plug-in submodule to be used on different PCBs.

The submodule supplies the strain gauge with a DC voltage and generates a signal proportional to the expansion changes of the strain gauge. Located on the submodule is a sensor gain adjustment and settings for a low-pass filter.

See the SGS portions of the E-801 User Manual for details.

3.3.2 E-802 Position Servo-Control Submodule

The E-802 submodule produces an analog control signal for the power amplifier driving the actuator. Slew rate limitation, notch filter and servo-control loop are all implemented on the E-802.

The servo-loop logic compares the control voltage input (target) and the sensor signal (current position) to generate the amplifier control signal using an analog proportional-integral (P-I) algorithm.

For calibration procedures, see Section 4 and the E-802 Servo-Control Submodule User Manual.

4 Calibration

Note that upon delivery the system is ready for operation: all of PI's positioning systems with a piezo actuator are delivered with performance test documents to verify the system performance, and calibration of the controller is done prior to delivery in our lab. Actuators and assigned controller channels are matched and should be kept together as a unit. The serial number of the actuator assigned to each channel is marked on the individual controller.

Normally there is no need for you to recalibrate the system. Only exchanging the actuator, the mechanical setup, replacing the cables on the actuator or making a large change in the operating temperature, may make recalibration necessary.

The only procedure which is necessary from time to time is the zero-point adjustment (see below). All other calibration procedures—static gain adjustment¹ and dynamic calibration²—require special equipment and should only be done by qualified personnel and are required only in special circumstances. See the user manuals for the sensor processing and servo-control submodules (E-801 and E-802) for details regarding those procedures.

WARNING—HIGH VOLTAGE

E-651s and E-614s are amplifiers generating high voltages of up to 60 V for driving piezo actuators. The output power may cause serious injuries.

Working with these devices or using piezoelectric products from other manufacturers we strictly advise you to follow the General Accident Prevention Regulations.

All work done with and on the devices described here requires adequate knowledge of handling high voltages.



¹ The objective of static gain adjustment is to ensure that the actuator expands to its nominal expansion in "positive" direction when a control signal input of +5 V is applied (with DC-offset disabled).

² Dynamic calibration optimizes step response and suppresses resonance, overshoot, and oscillation.



CAUTION

The E-651 and E-614 controller/amplifier PCBs and their submodule boards (E-801, E-802) are ESD-sensitive (electrostatic discharge sensitive) devices. Observe all precautions against static charge buildup before handling these devices.

Avoid touching circuit components, pins and PCB traces. Discharge any static charge you may have on your body by briefly touching a conductive, grounded object before you touch any electronic assembly. Pose PCBs only on conductive surfaces, such as ESD-safe transport containers (envelopes, foam). Electronic subassemblies must always be kept and transported/shipped in conductive packaging.

Make sure that no conductive particles of any kind (metallic dust or shavings, broken pencil leads, loose screws) get on the card.



CAUTION

Calibration of the controller is done prior to delivery by the manufacturer.

Do not adjust potentiometers unnecessarily. Any calibration procedures are to be carried out by qualified authorized personnel only.

4.1 Equipment Needed

Zero-point adjustment requires a voltmeter and a small straight-bladed screw driver.

4.2 Zero-Point Adjustment

Proper zero-point adjustment ensures that the full output voltage swing of the amplifier can be used without reaching the output voltage limits of the amplifier and causing overflow conditions, both in open-loop and closed-loop operation. If an overflow condition occurs (OFL LED lights up for the channel), it can often be prevented by re-adjusting the ZERO point.

The zero-point of each channel is adjusted with the appropriate ZERO potentiometer (E-651: ZERO potentiometer for each accessible through the front panel; E-614: R132 for channel 1,

R133 for channel 2; see p. 15 for component locations). This potentiometer shifts the output of the sensor processing circuitry and hence the values on the sensor monitor output (E-651: front panel; E-614: MON-DMS1 and MON-DMS2 test points) and sensor-input lines of the servo-loop submodule.

To adjust the zero-point for a channel proceed as follows:

1. Before powering up the system, make sure the actuator is mounted in the same way and with the same load as during normal operations in the application. In multi-axis systems, make sure the actuators are always connected to the same controller channels.
2. Make sure the analog control input (E-651: front panel; E-614: connector X20) is at 0 V.
3. Set the channel to open-loop mode (E-651: SERVO OFF; E-614: EC/VC switch (p. 15) to VC)
4. E-614 only: close jumper X7 (channel 2) and X10 (channel 1) to disable any DC offset potentiometer.
5. Power up the system.
6. Deflect the actuator over its full range by sweeping the control input signal over the range of -5 V to +5 V.
7. Hold the control input signal at -5 V.
8. Adjust the ZERO potentiometer so that the sensor-monitor signal is 0 V.

Normally the zero-point adjustment can be finished at this point. Now you can switch the channel to closed-loop mode and deflect the actuator over the full range by applying a control input voltage of -5 to +5 V. The overflow LED should not light up. If the overflow LED does light, repeat steps 2 to 8.

Failure of the zero-point re-adjustment (i.e. overflow LED still lights up) could indicate a serious problem. See "Troubleshooting" section for information on how to proceed.

5 Troubleshooting

5.1 Typical Problems

Problem	Possible Causes	Solutions
Actuator does not move	Cables not connected or connected to wrong socket	Check the connecting cables
	Cable is defective	Contact your PI sales engineer or write info@pi.ws .
	Bender actuator defective	Replace actuator with a working one, to test a new combination of actuator and controller (note that if you want to use the new actuator in regular operation a fully recalibration of the system is required) and contact your PI sales engineer or write info@pi.ws .
	Control input voltage source defective	Repair or replace voltage source
	Controller will not power up	Check POWER LED (with E-614 not included), power supply and line voltage connection
Overflow LED lights up	Commanded output voltage outside the allowed range (0 to +60 V)	Re-adjust the zero-point (see p. 22). If this is not successful, contact your PI sales engineer or write info@pi.ws .
	Control input signal outside the allowed range (-5 V to +5 V)	Use a suitable control input signal

5.2 Opening the E-651 Case

CAUTION



Note that E-651 / E-614 controller/amplifier do not contain any user-serviceable parts.

Some adjustment elements on the main board and on the E-801 and E-802 submodules are covered with sealing lacquer. Damage to the seal will void the warranty except in consultation with PI.

Should it ever be necessary to open the E-651 case, e.g. for a static gain adjustment procedure, proceed as follows:

1. Switch off the controller and disconnect the power supply.
2. Use a Torx 8 driver to unscrew the 2 screws in the blue frame on the rear panel and carefully remove the rear panel.
3. Use the Torx 8 driver to unscrew the 2 screws in the blue frame on the front panel. Carefully remove the front panel, which also pulls the PCB out of the case (the rear panel must be turned and pulled carefully through the case too).
4. Reconnect the power supply to the socket on the rear panel. Keep the system powered down.

6 Technical Data

6.1 Specifications

Model	E-651.1S	E-651.2S	E-614.2BS
Function	Power amplifier & sensor/position servo-controller for multilayer bender actuators, bench-top controller	Power amplifier & sensor/position servo-controller for multilayer bender actuators, bench-top controller	Power amplifier & sensor/position servo-controller for multilayer bender actuators, OEM board
Channels	1	2	2
AMPLIFIER:			
Maximum output power	1 W	1 W / channel	1 W / channel
Average output power	0.5 W	0.5 W / channel	0.5 W / channel
Peak output current 5 ms	36 mA	36 mA	36 mA
Average output current	18 mA	18 mA	18 mA
Voltage gain	6	6	6
Polarity	Positive	Positive	Positive
Control input voltage	-5 V to +5 V	-5 V to +5 V	-5 V to +5 V
Output voltage	0 V to +60 V	0 V to +60 V	0 V to +60 V
DC offset setting	-	-	0 to +60 V with ext. potentiometer (not included)
Input Impedance	100 kΩ	100 kΩ	100 kΩ
Control input socket	BNC	BNC	On-board connector
PZT (bender actuator) voltage and sensor input socket	LEMO EPG.0B.307.HLN, sensor and PZT lines in one connector	LEMO EPG.0B.307.HLN, sensor and PZT lines in one connector	Separate on-board connectors for PZT output voltages and sensor input
POSITION SERVO-CONTROL			
Sensor Type	SGS	SGS	SGS
Sensor excitation	5 V DC, adjustable	5 V DC, adjustable	5 V DC, adjustable
Low-pass cut-off frequency	100 Hz / 5 kHz selectable	100 Hz / 5 kHz selectable	100 Hz / 5 kHz selectable
Monitor output	0 V to +10 V for nominal displacement	0 V to +10 V for nominal displacement	0 V to +10 V for nominal displacement
Sensor monitor output socket	BNC	BNC	On-board connector
Dimensions	125 x 90 x 265 mm	125 x 90 x 265 mm	Open frame board, 100 x 40 x 200 mm
Weight	1.36 kg	1.45 kg	0.30 kg
Operating voltage	14 to 16 V DC (power supply C-890.PS included)	14 to 16 V DC (power supply C-890.PS included)	14 to 16 V DC

6.2 Pin Assignment

6.2.1 E-651 PZT & SENSOR connector

LEMO connector EPG.0B.307.HLN

Pin	Function
1	GND (actuator)
2	Sensor input (-)
3	Sensor input (+)
4	GND (SGS)
5	+ 60 V
6	Variable output voltage (actuator control)
7	SGS reference voltage



6.2.2 E-614 Sensor Input Connectors

For component locations and more pinouts see Fig. 6 on p. 15.

(Connector X19 for channel 1, X17 for channel 2)

Pin	Function
1	SGS reference voltage
2	Sensor input (+)
3	Sensor input (-)
4	SGS GND

